

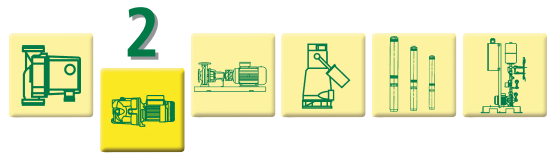





SELF-PRIMING AND MULTISTAGE CENTRIFUGAL PUMPS



PUMP PERFORMANCE



TECHNICAL CATALOGUE SECTIONS:

- 1  WET ROTOR CIRCULATORS AND IN-LINE PUMPS
- 2  **SELF-PRIMING AND MULTISTAGE CENTRIFUGAL PUMPS**
- 3  CENTRIFUGAL PUMPS
- 4  SUBMERSIBLE PUMPS
- 5  SUBMERGED PUMPS
- 6  BOOSTER SETS

CONTENTS

SELF-PRIMING PUMPS	JET JETINOX JETCOM	page 4-18
MULTISTAGE PUMPS	EURO EUROINOX (SELF-PRIMING) EUROCOM	page 19-30
FITTED PUMPS	JET - JETINOX MP EURO - EUROINOX MP	page 31-33
ACTIVE SYSTEM	ACTIVE J - ACTIVE JI - ACTIVE JC ACTIVE E - ACTIVE EI - ACTIVE EC	page 34-40
ACTIVE DRIVER	ACTIVE DRIVER	page 41-45
INVERTER-COMMANDED PUMPS	AD JET - AD EURO	page 46-49
AUTOMATIC PUMPING UNITS	AQUAJET AQUAJET-INOX	page 50-55
GARDEN PUMPS	GARDENJET GARDEN-INOX GARDEN-COM	page 56-60
PUMPS FOR DEEP SUCTION	DP	page 61-63
PUMPS FOR SWIMMING-POOL APPLICATIONS	EUROSWIM JETCOM SP EUROCOM SP EUROCOVER	page 64-76 page 77-78
SYSTEM FOR EXPLOITATION OF RAINWATER	ACTIVE SWITCH - AQUAPROF	page 79-82

SELF-PRIMING PUMPS

PERFORMANCE RANGE

GRAPHIC SELECTION TABLE

The performance curves are based on the kinematic viscosity values = 1 mm²/s and density equal to 1000 kg/m³. Curve tolerance according to ISO 9906.

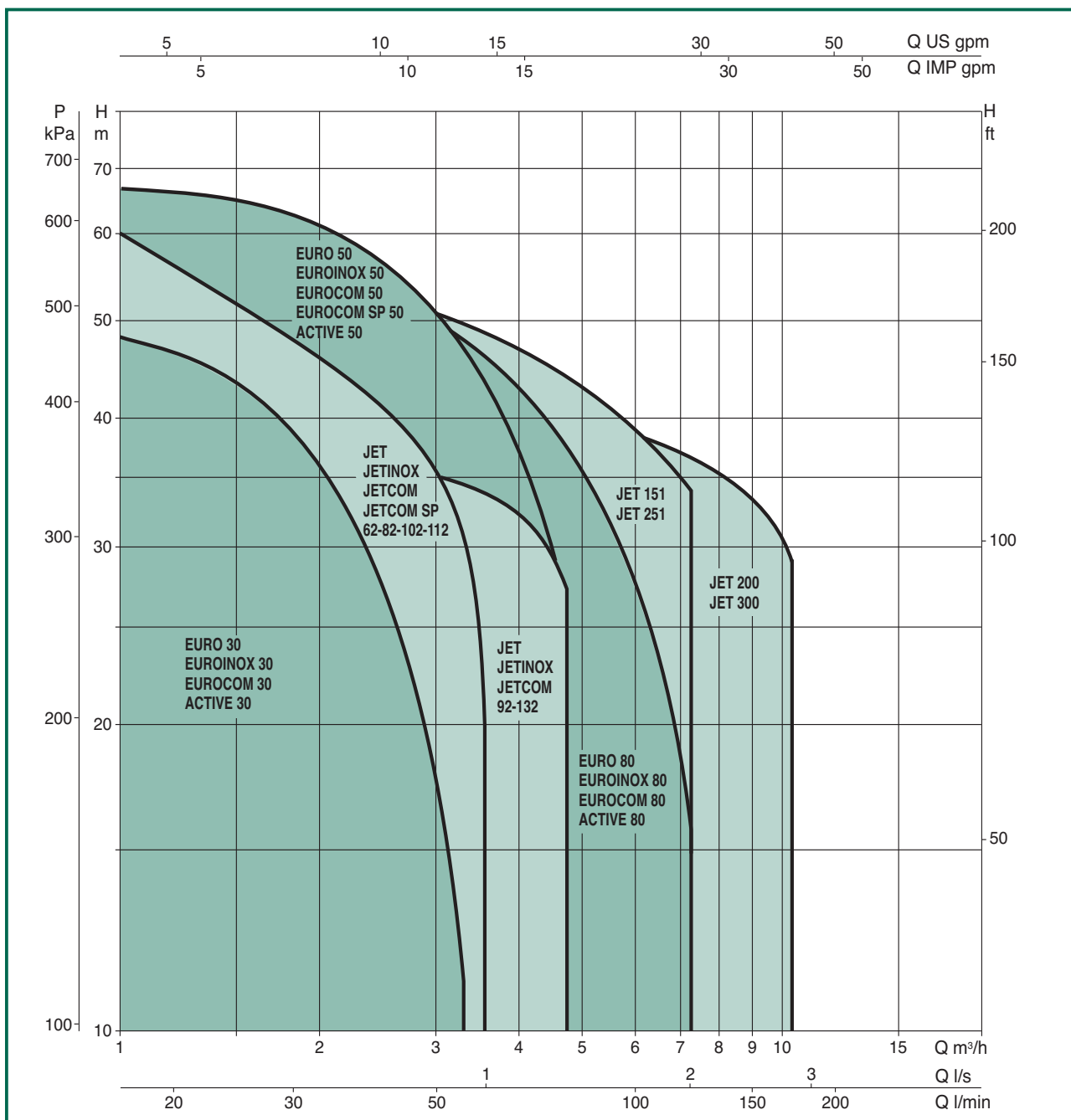

PERFORMANCE RANGE

NUMERICAL SELECTION TABLE

MODEL		P2 NOMINAL		Q																
SINGLE-PHASE	THREE-PHASE	kW	HP	H (m)																
				0	0,6	1,2	1,8	2,4	3	3,6	4,2	4,8	6	7,2	9	9,6	10,5			
				ms/h	0	10	20	30	40	50	60	70	80	100	120	150	160	175		
				l/min	0	10	20	30	40	50	60	70	80	100	120	150	160	175		
JET 62 M *	JET 62 T	0,44	0,6	42	35	29,2	25,6	22,9	21,1											
JET 82 M *	JET 82 T	0,6	0,8	47	40	34	30	26,2	23,5	20,3										
JET 102 M *	JET 102 T	0,75	1	53,8	47	41	36,3	32,4	28,8	25,8										
JET 112 M *	JET 112 T	1	1,36	61	54	47,8	42,8	38,8	34,8	20										
JET 92 M *	JET 92 T	0,75	1	36,2	33,5	31	28,4	26	24	21,8	19,6	17								
JET 132 M *	JET 132 T	1	1,36	48,3	45,6	42,8	40	37,6	35	32,5	30	27,2								
JETINOX 82 M *	JETINOX 82 T	0,6	0,8	47	40	34	30	26,2	23,5	20,3										
JETINOX 102 M *	JETINOX 102 T	0,75	1	53,8	47	41	36,3	32,4	28,8	25,8										
JETINOX 112 M *	JETINOX 112 T	1	1,36	61	54	47,8	42,8	38,8	34,8	20										
JETINOX 92 M *	JETINOX 92 T	0,75	1	36,2	33,5	31	28,4	26	24	21,8	19,6	17,5								
JETINOX 132 M *	JETINOX 132 T	1	1,36	48,3	45,6	42,8	40	37,6	35	32,5	30	27,2								
JETCOM 62 M *	JETCOM 62 T	0,44	0,6	42	35	29,2	25,6	22,9	13											
JETCOM 82 M *	JETCOM 82 T	0,6	0,8	47	40	34	30	26,2	23,5	20										
JETCOM 102 M *	JETCOM 102 T	0,75	1	53,8	47	41	36,3	32,4	28,8	25,8										
JETCOM 92 M *	JETCOM 92 T	0,75	1	36,2	33,5	31	28,4	26	24	21,8	19,6	17,5								
JETCOM 132 M *	JETCOM 132 T	1	1,36	48,3	45,6	42,8	40	37,6	35	32,5	30	27,2								
JET 151 M	JET 151 T	1,1	1,5	61	58,2	56	53	50	46	43	36									
JET 251 M	JET 251 T	1,85	2,5	62	60	58	56	54	51	48,5	46	43,5	39	34,2						
JET 200 M	-	1,5	2	41			37,5	36,5	35,2	34	33	31,8	29,5	27,2	24	22,8	21,3			
-	JET 200 T	1,5	2	46,5			43	41,8	40,5	39,2	38	37	34,2	31,8	28	26,8	25			
JET 300 M	JET 300 T	2,2	3	51			48	47	46	44,5	43	42	40	37	33	32	29			
EURO 25/30 M *	EURO 25/30 T	0,37	0,5	34,4	31,7	28,3	23,5	17,5	11											
EURO 30/30 M *	EURO 30/30 T	0,45	0,6	46	42,2	37,8	31,2	23,3	14,3											
EURO 40/30 M *	EURO 40/30 T	0,55	0,75	57	52,7	47	38,8	29	17,7											
EURO 30/50 M *	EURO 30/50 T	0,55	0,75	42,5	40,2	38,2	36,2	33,8	30	24,8	19,5	14								
EURO 40/50 M *	EURO 40/50 T	0,75	1	57,5	55,3	52,8	50,1	47,1	42,7	35,8	28	19								
EURO 50/50 M *	EURO 50/50 T	1	1,36	72	68,5	65,5	62,1	58,2	52,2	43,6	34,5	26								
EURO 25/80 M *	EURO 25/80 T	0,55	0,75	34		33	32	30,5	28,5	26	23,5	21	14,5	6,5						
EURO 30/80 M *	EURO 30/80 T	0,8	1,1	47		46,5	45	43,5	41	38	34,5	31	23	12						
EURO 40/80 M *	EURO 40/80 T	1	1,36	59		57	56	54	51	47	43,5	39	29,5	16,5						
EUROINOX 25/30 M *	EUROINOX 25/30 T	0,37	0,5	34	31,7	28,3	23,5	17,5	11											
EUROINOX 30/30 M *	EUROINOX 30/30 T	0,45	0,6	46	42,2	37,8	31,2	23,3	14,3											
EUROINOX 40/30 M *	EUROINOX 40/30 T	0,55	0,75	57	52,7	47	38,8	29	17,7											
EUROINOX 30/50 M *	EUROINOX 30/50 T	0,55	0,75	42	40,2	38,2	36,2	33,8	30	24,8	19,5	14								
EUROINOX 40/50 M *	EUROINOX 40/50 T	0,75	1	58	55,3	52,8	50,1	47,1	42,7	35,8	28	19								
EUROINOX 50/50 M *	EUROINOX 50/50 T	1	1,36	72	68,5	65,5	62,1	58,2	52,2	43,6	34,5	26								
EUROINOX 25/80 M *	EUROINOX 25/80 T	0,55	0,75	34		33	32	30,5	28,5	26	23,5	21	14,5	6,5						
EUROINOX 30/80 M *	EUROINOX 30/80 T	0,8	1,1	47		46,5	45	43,5	41	38	34,5	31	23	12						
EUROINOX 40/80 M *	EUROINOX 40/80 T	1	1,36	59		57	56	54	51	47	43,5	39	29,5	16,5						
EUROCOM 25/30 M *	EUROCOM 25/30 T	0,37	0,5	34,4	31,7	28,3	23,5	17,5	11											
EUROCOM 30/30 M *	EUROCOM 30/30 T	0,45	0,6	46	42,2	37,8	31,2	23,3	14,3											
EUROCOM 30/50 M *	EUROCOM 30/50 T	0,55	0,75	42,2	40,2	38,2	36,2	33,8	30	24,8	19,5	14								
EUROCOM 40/50 M *	EUROCOM 40/50 T	0,8	1,1	57,7	55,3	52,8	50,1	47,1	42,7	35,8	28	19,2								
EUROCOM 25/80 M *	EUROCOM 25/80 T	0,55	0,75	34		33	32	30,5	28,5	26	23,5	21	14,5	6,5						
EUROCOM 30/80 M *	EUROCOM 30/80 T	0,8	1,1	47		46,5	45	43,5	41	38	34,5	31	23	12						
JETCOM SP 102 M	JETCOM SP 102 T	0,75	1	53,8	47	41	36,3	32,4	28,8	25,8										
EUROCOM SP 30/50 M	EUROCOM SP 30/50 T	0,55	0,75	42,2	40,2	38,2	36,2	33,8	30	27,5	24,8	19,5	14							
EUROCOM SP 40/50 M	EUROCOM SP 40/50 T	0,75	1	57,7	55,3	52,8	50,1	47,1	42,7	39,5	35,8	28	19,2							

* Also for correspondent ACTIVE version.

JET



JET 200-300



JET 62-82-102-112-92-132

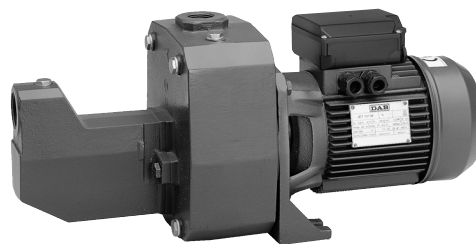

JET 151-251



GENERAL DATA

Applications

Self-priming centrifugal pump with excellent suction capacity even when there are air bubbles and small particles of sand in the water.

Used especially for supplying water to domestic installations. Ideal for use in small-scale agriculture and gardening, limited industrial services and wherever self-priming operation is necessary.

Constructional features of the pump

Cast iron pump body and motor support.

Motor support in die-cast aluminium for Jet 62-82-102-112-92-132.

Technopolymer impeller, diffuser, Venturi tube and sand guard.

Stainless steel pressure discs.

Carbon/ceramic mechanical seal.

Constructional features of the motor

Induction motor, closed and cooled with external ventilation.

Rotor mounted on oversized greased sealed-for-life ball bearings to ensure silent running and long life.

Built-in thermal and current overload protection and a capacitor permanently in circuit in the single-phase version.

Three-phase motors should be protected with a suitable overload protection complying with the regulations in force.

Manufactured according to CEI 2-3 and CEI 61-69 standards (EN 60335-2-41).

Motor protection: IP 44

Terminal box protection: IP 55

Insulation class: F

Standard voltage: single-phase 220-240 V/50 Hz
 three-phase 230-400 V/50 Hz

TECHNICAL DATA

N.	PARTS*	MATERIALS	MODELS
1	PUMP BODY	CAST IRON 200 UNI ISO 185	
3	SUPPORT	CAST IRON 200 UNI ISO 185 DIE-CAST ALUMINIUM	JET 151; 251; 200; 300 JET 62; 82; 102; 112; 92; 132
4	IMPELLER	TECHNOPOLYMER A	
7	SHAFT WITH ROTOR	STAINLESS STEEL AISI 416 X12 CrS13 - UNI 6900/71	
16	MECHANICAL SEAL	CARBON/CERAMIC	
28	OR GASKET	NBR RUBBER	
160	NOZZLE-VENTURI DIFFUSER ASSEMBLY	TECHNOPOLYMER A	

* In contact with the liquid.

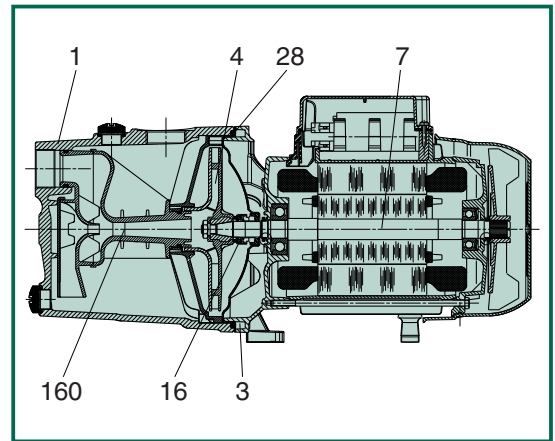

Self priming capacity

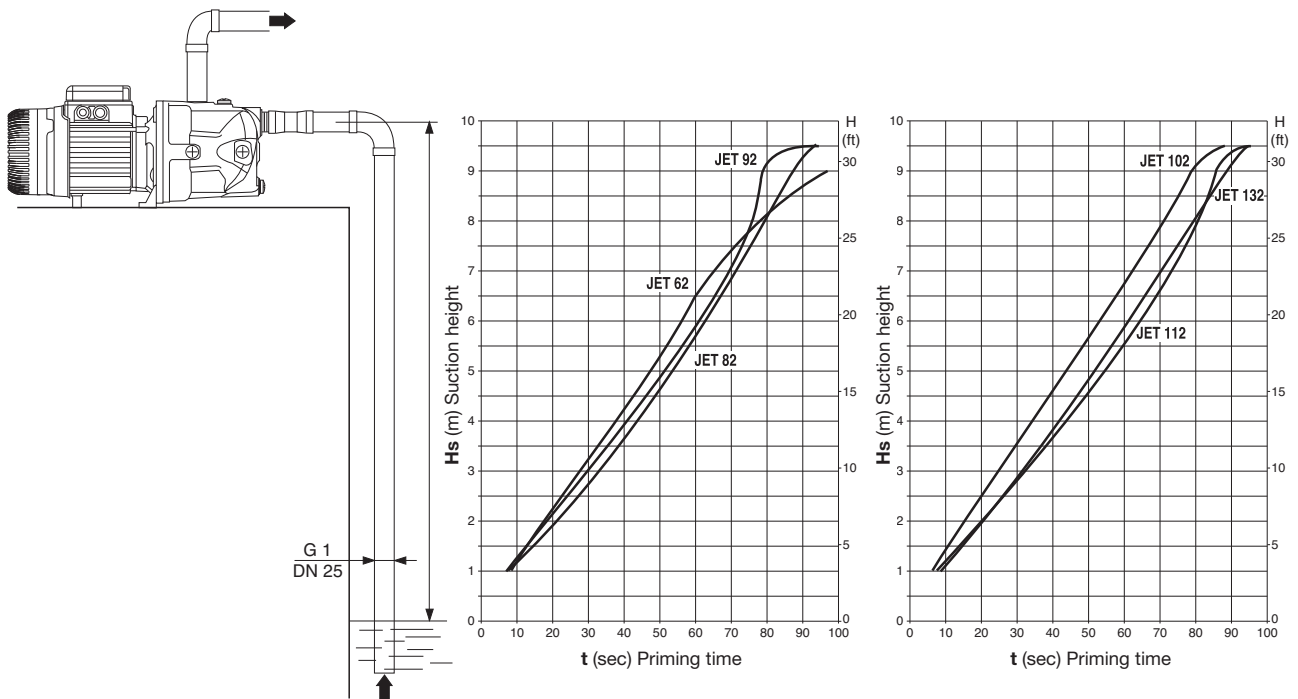

- Operating range: from 0,4 to 10,5 m³/h with head up to 62 metres
- Liquid quality requirements: clean, free from solids or abrasive substances, non viscous, non aggressive, non crystallized, chemically neutral, close to the characteristics of water.
- Liquid temperature range: from 0°C to +35°C for domestic use (EN 60335-2-41)
from 0°C to +40°C for other uses
- Maximum ambient temperature: +40°C
- Maximum operating pressure: 8 bar (800 kPa)
- Installation: fixed in a horizontal position
- Special executions on request: other voltages and/or frequencies

The performance curves are based on the kinematic viscosity values = 1 mm²/s and density equal to 1000 kg/m³. Curve tolerance according to ISO 9906.

Liquid temperature range: from 0 °C to +35°C

Maximum ambient temperature: +40°C

JET 62

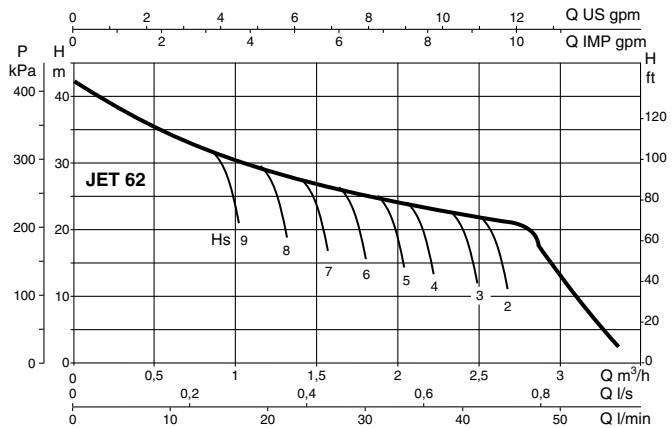
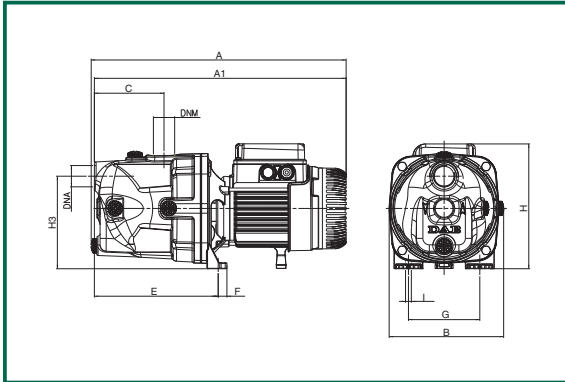

MODEL	A	A1	B	C	E	F	G	H	H3	I	DNA	DNM	PACKING DIMENSIONS			VOLUME m ³	WEIGHT Kg
													L/A	L/B	H		
JET 62	395	390	178	108	192	14	111	193	144	9	1" G	1" G	470	240	240	0,022	10,5

MODEL	ELECTRICAL DATA							HYDRAULIC DATA (n ≈ 2850 1/min)							
	VOLTAGE 50 Hz	P1 MAX kW	P2 NOMINAL		In A	CAPACITOR		Q m ³ /h l/min	H						
			kW	HP		μF	Vc		0	0,6	1,2	1,8	2,4	2,7	3,6
JET 62 M	1x220-240 V ~	0,72	0,44	0,6	3,12	12,5	450	H (m)	42	35	29,2	25,6	22,9	21,1	-
JET 62 T	3x230-400 V ~	0,67	0,44	0,6	2,1-1,2	-	-								

JET 82

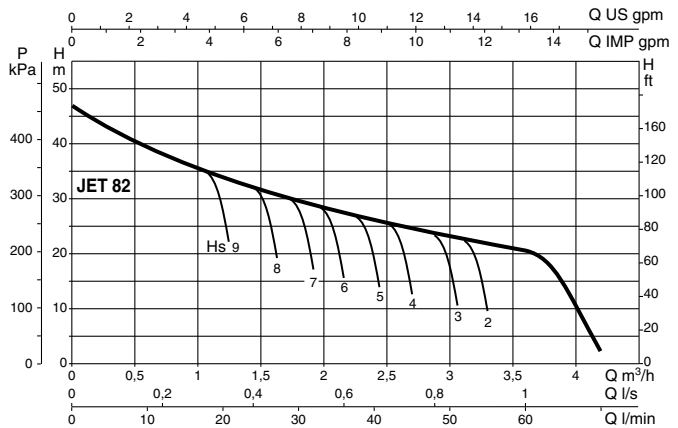
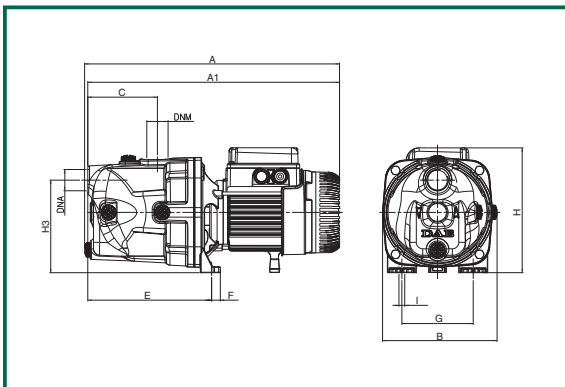

MODEL	A	A1	B	C	E	F	G	H	H3	I	DNA	DNM	PACKING DIMENSIONS			VOLUME m ³	WEIGHT Kg
													L/A	L/B	H		
JET 82	395	395	178	108	192	14	111	193	144	9	1" G	1" G	470	240	240	0,022	10,7

MODEL	ELECTRICAL DATA							HYDRAULIC DATA (n ≈ 2750 1/min)							
	VOLTAGE 50 Hz	P1 MAX kW	P2 NOMINAL		In A	CAPACITOR		Q m ³ /h l/min	H						
			kW	HP		μF	Vc		0	0,6	1,2	1,8	2,4	3	3,6
JET 82 M	1x220-240 V ~	0,85	0,6	0,8	3,2	12,5	450	H (m)	47	40	34	30	26,2	23,5	20,3
JET 82 T	3x230-400 V ~	0,86	0,6	0,8	2,8-1,6	-	-								

The performance curves are based on the kinematic viscosity values = 1 mm²/s and density equal to 1000 kg/m³. Curve tolerance according to ISO 9906.
 Liquid temperature range: from 0 °C to +35°C
 Maximum ambient temperature: +40°C

JET 102

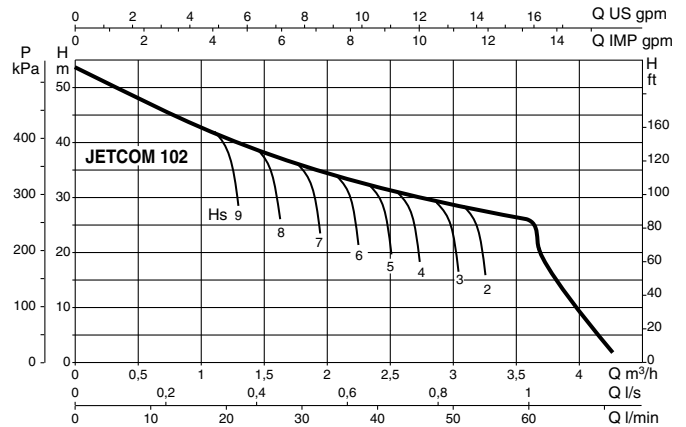
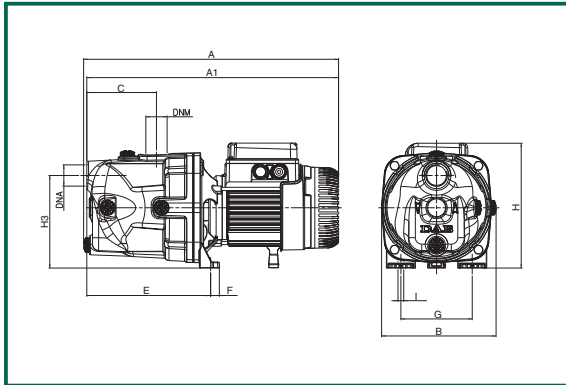

MODEL	A	A1	B	C	E	F	G	H	H3	I	DNA	DNM	PACKING DIMENSIONS			VOLUME m ³	WEIGHT Kg
													L/A	L/B	H		
JET 102	414	409	178	108	197	14	111	203	144	9	1" G	1" G	470	240	240	0,022	12,5

MODEL	ELECTRICAL DATA						HYDRAULIC DATA (n ≈ 2800 1/min)								
	VOLTAGE 50 Hz	P1 MAX kW	P2 NOMINAL		In A	CAPACITOR μF Vc	Q								
			kW	HP			m ³ /h l/min	0	0,6 10	1,2 20	1,8 30	2,4 40	3 50	3,6 60	
JET 102 M	1x220-240 V ~	1,13	0,75	1	5,1	16	450	H (m)	53,8	47	41	36,3	32,4	28,8	25,8
JET 102 T	3x230-400 V ~	1,04	0,75	1	3,3-1,9	-	-								

JET 112

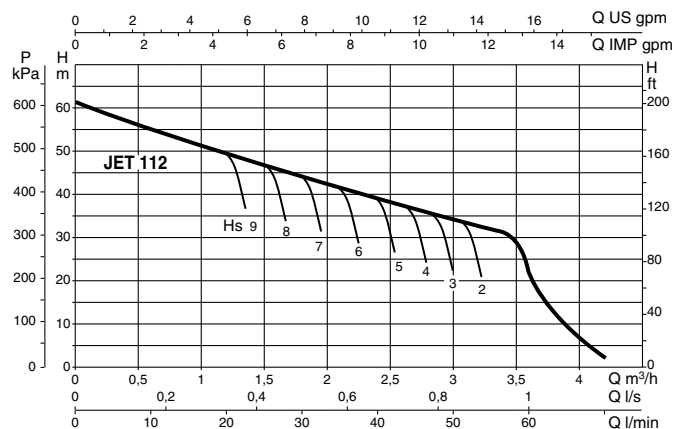
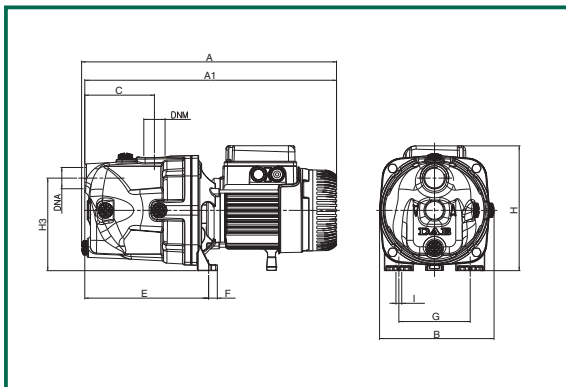

MODEL	A	A1	B	C	E	F	G	H	H3	I	DNA	DNM	PACKING DIMENSIONS			VOLUME m ³	WEIGHT Kg
													L/A	L/B	H		
JET 112	414	409	178	108	192	14	111	203	144	9	1" G	1" G	470	240	240	0,022	13,5

MODEL	ELECTRICAL DATA						HYDRAULIC DATA (n ≈ 2750 1/min)								
	VOLTAGE 50 Hz	P1 MAX kW	P2 NOMINAL		In A	CAPACITOR μF Vc	Q								
			kW	HP			m ³ /h l/min	0	0,6 10	1,2 20	1,8 30	2,4 40	3 50	3,6 60	
JET 112 M	1x220-240 V ~	1,4	1	1,36	6,2	25	450	H (m)	61	54	47,8	42,8	38,8	34,8	20
JET 112 T	3x230-400 V ~	1,35	1	1,36	4,3-2,5	-	-								

The performance curves are based on the kinematic viscosity values = 1 mm²/s and density equal to 1000 kg/m³. Curve tolerance according to ISO 9906.

Liquid temperature range: from 0 °C to +35°C
 Maximum ambient temperature: +40°C

JET 92

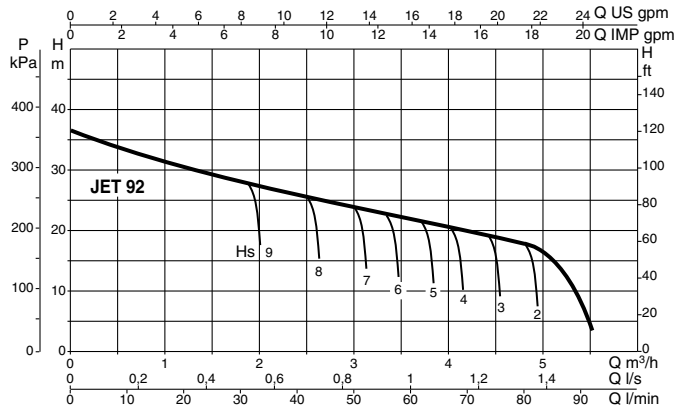
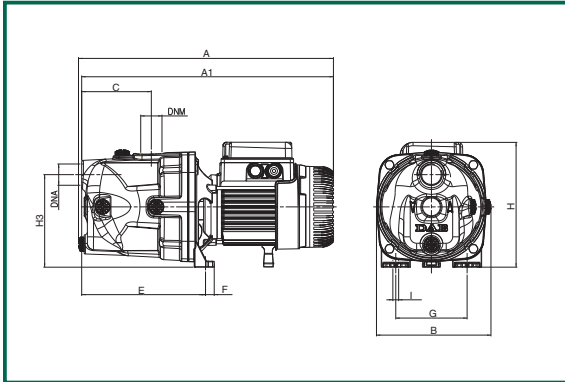

MODEL	A	A1	B	C	E	F	G	H	H3	I	DNA	DNM	PACKING DIMENSIONS			VOLUME	WEIGHT
													L/A	L/B	H	m ³	Kg
JET 92	395	390	178	108	192	14	111	193	144	9	1" G	1" G	470	240	240	0,022	11,7

MODEL	ELECTRICAL DATA						HYDRAULIC DATA (n ≈ 2750 1/min)											
	VOLTAGE 50 Hz	P1 MAX kW	P2 NOMINAL		In A	CAPACITOR	Q	0	0,6	1,2	1,8	2,4	3	3,6	4,2	4,8		
			kW	HP		μF	Vc	m ³ /h	l/min	0	10	20	30	40	50	60	70	80
JET 92 M	1x220-240 V ~	0,94	0,75	1	4,2	14	450	H	36,2	33,5	31	28,4	26	24	21,8	19,6	17	
JET 92 T	3x230-400 V ~	0,93	0,75	1	3,3-1,9	-	-	(m)										

JET 132

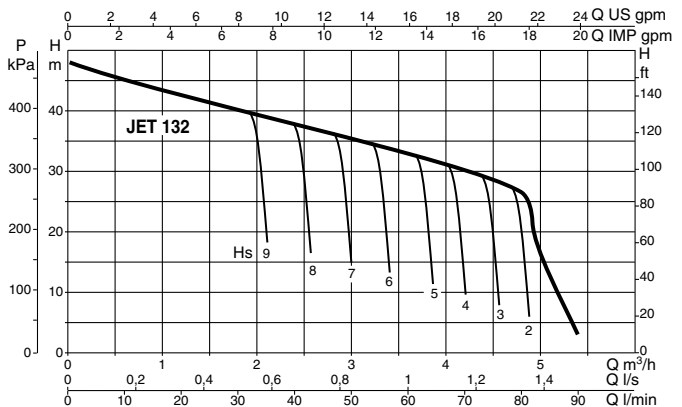
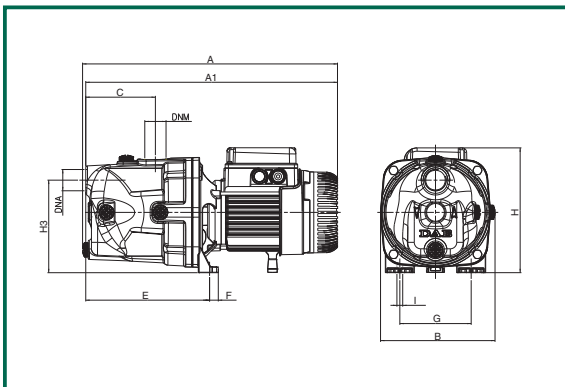

MODEL	A	A1	B	C	E	F	G	H	H3	I	DNA	DNM	PACKING DIMENSIONS			VOLUME	WEIGHT
													L/A	L/B	H	m ³	Kg
JET 132	414	409	263	108	192	14	111	203	144	9	1" G	1" G	470	240	240	0,022	13,5

MODEL	ELECTRICAL DATA						HYDRAULIC DATA (n ≈ 2750 1/min)											
	VOLTAGE 50 Hz	P1 MAX kW	P2 NOMINAL		In A	CAPACITOR	Q	0	0,6	1,2	1,8	2,4	3	3,6	4,2	4,8		
			kW	HP		μF	Vc	m ³ /h	l/min	0	10	20	30	40	50	60	70	80
JET 132 M	1x220-240 V ~	1,49	1	1,36	6,6	25	450	H	48	45,6	42,8	40	37,6	35	32,5	30	27	
JET 132 T	3x230-400 V ~	1,43	1	1,36	4,7-2,7	-	-	(m)										

The performance curves are based on the kinematic viscosity values = 1 mm²/s and density equal to 1000 kg/m³. Curve tolerance according to ISO 9906.

Liquid temperature range: from 0 °C to +35°C
 Maximum ambient temperature: +40°C

JET 151

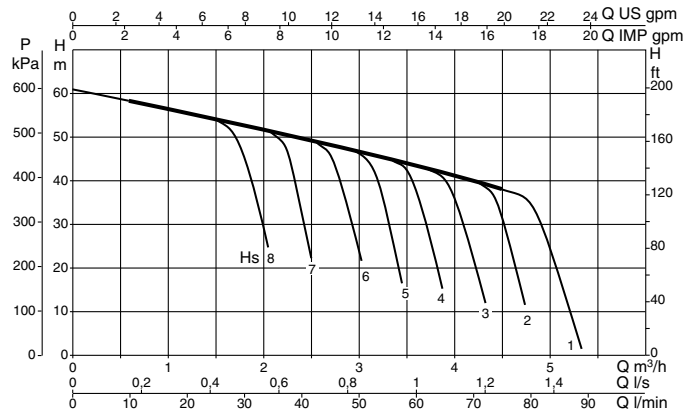
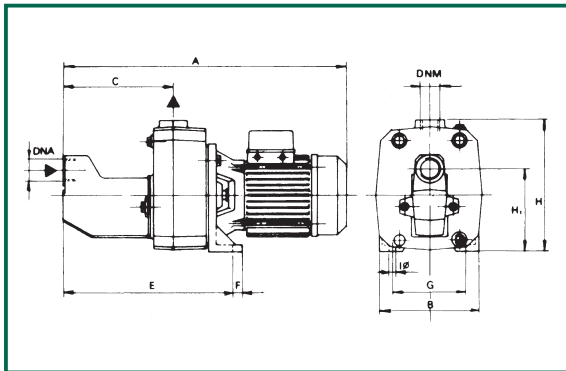

MODEL	A	B	C	E	F	G	I Ø	H	H1	DNA	DNM	PACKING DIMENSIONS			VOLUME m ³	WEIGHT Kg
												L/A	L/B	H		
JET 151	558	210	221	350	20	145	11	255	158	1 1/4" G	1" G	612	248	279	0,042	31

MODEL	ELECTRICAL DATA						HYDRAULIC DATA (n ≈ 2800 1/min)										
	VOLTAGE 50 Hz	P1 MAX kW	P2 NOMINAL		In A	CAPACITOR		Q									
			kW	HP		μF	Vc	m ³ /h	l/min	0	0,6	1,2	1,8	2,4	3	3,6	4,2
JET 151 M	1x220-240 V ~	1,6	1,1	1,5	7,2	31,5	450	H (m)	61	58,2	56	53	50	46	43	39,5	36
JET 151 T	3x230-400 V ~	1,6	1,1	1,5	5,2-3	-	-										

JET 251

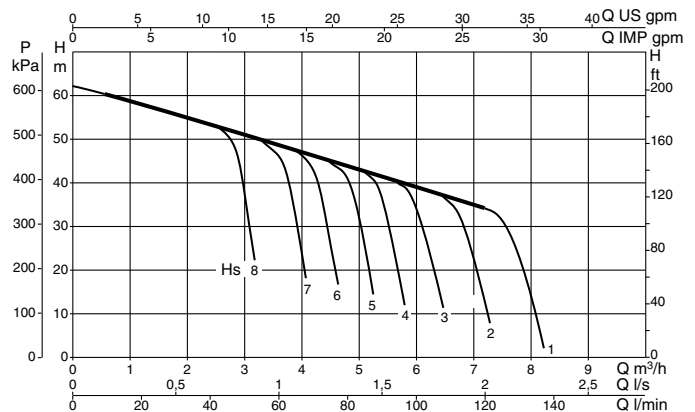
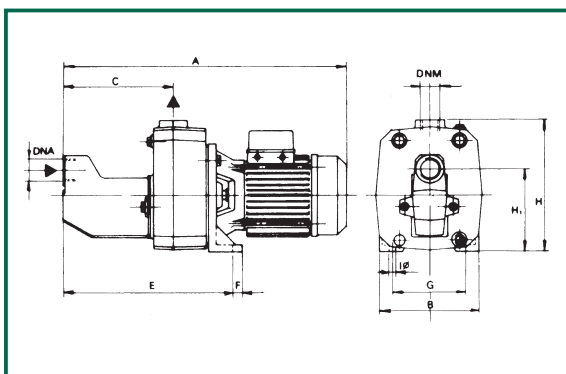

MODEL	A	B	C	E	F	G	I Ø	H	H1	DNA	DNM	PACKING DIMENSIONS			VOLUME m ³	WEIGHT Kg
												L/A	L/B	H		
JET 251 M	632	210	221	350	20	145	11	255	158	1 1/4" G	1" G	657	248	279	0,045	35
JET 251 T	558	210	221	350	20	145	11	255	158	1 1/4" G	1" G	612	248	279	0,042	31

MODEL	ELECTRICAL DATA						HYDRAULIC DATA (n ≈ 2800 1/min)												
	VOLTAGE 50 Hz	P1 MAX kW	P2 NOMINAL		In A	CAPACITOR		Q											
			kW	HP		μF	Vc	m ³ /h	l/min	0	0,6	1,2	1,8	2,4	3	3,6	4,2	4,5	6
JET 251 M	1x220-240 V ~	2,2	1,85	2,5	10	40	450	H (m)	62	60	58	56	54	51	48,5	46	43,5	39	34,2
JET 251 T	3x230-400 V ~	2,2	1,85	2,5	6,9-4	-	-												

The performance curves are based on the kinematic viscosity values = 1 mm²/s and density equal to 1000 kg/m³. Curve tolerance according to ISO 9906.

Liquid temperature range: from 0 °C to +35°C
 Maximum ambient temperature: +40°C

JET 200

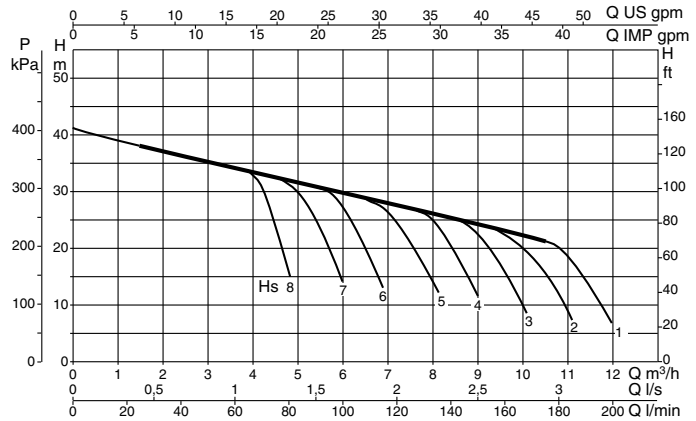
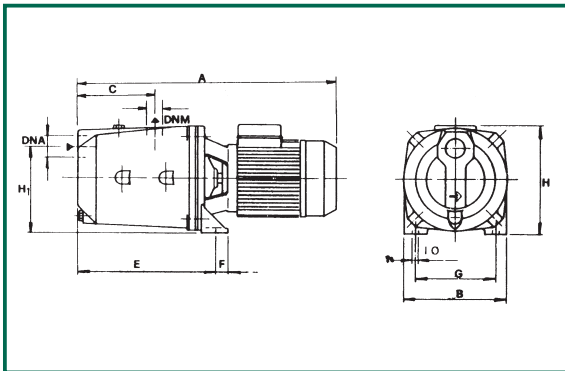

MODEL	A	B	C	E	F	G	I Ø	H	H1	DNA	DNM	PACKING DIMENSIONS			VOLUME m ³	WEIGHT Kg
												L/A	L/B	H		
JET 200	521	214	151	282	20	160	11	227	175	1½" G	1¼" G	612	248	279	0,042	27

MODEL	ELECTRICAL DATA						HYDRAULIC DATA (n ≈ 2850 1/min)											
	VOLTAGE 50 Hz	P1 MAX kW	P2 NOMINAL		In A	CAPACITOR		Q m ³ /h l/min	H									
			kW	HP		µF	Vc		0	1,5	2,4	3,6	4,8	6	7,2	9	10,5	
JET 200 M	1x220-240 V ~	2,0	1,5	2	9	31,5	450	H	41	38	36,5	34	31,8	29,5	27,2	24	21,3	
JET 200 T	3x230-400 V ~	2,0	1,5	2	6,8-3,9	-	-	(m)	46,5	43,5	41,8	39,2	37	34,2	31,8	28	25	

JET 300

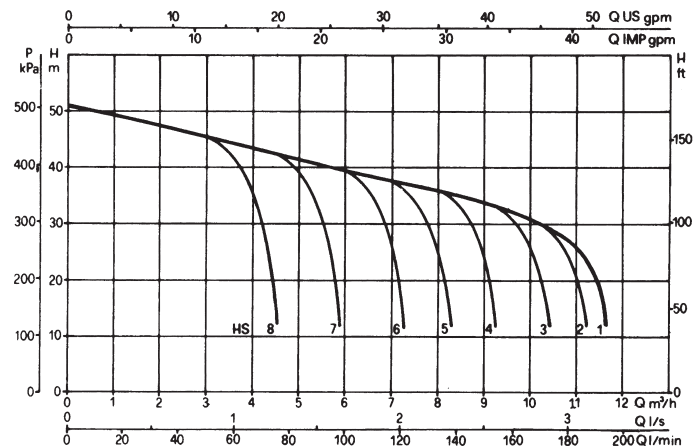
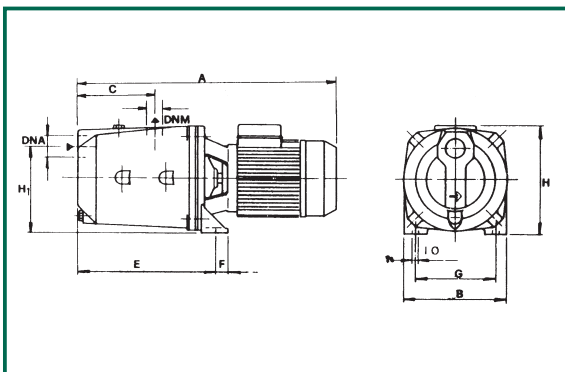

MODEL	A	B	C	E	F	G	I Ø	H	H1	DNA	DNM	PACKING DIMENSIONS			VOLUME m ³	WEIGHT Kg
												L/A	L/B	H		
JET 300 M	595	214	151	282	20	160	11	235	175	1½" G	1¼" G	657	248	279	0,045	31,5
JET 300 T	521	214	151	282	20	160	11	227	175	1½" G	1¼" G	612	248	279	0,042	27

MODEL	ELECTRICAL DATA						HYDRAULIC DATA (n ≈ 2850 1/min)											
	VOLTAGE 50 Hz	P1 MAX kW	P2 NOMINAL		In A	CAPACITOR		Q m ³ /h l/min	H									
			kW	HP		µF	Vc		0	1,5	1,8	2,4	3,6	4,8	6	7,2	9	10,5
JET 300 M	1x220-240 V ~	2,7	2,2	3	12	40	450	H	51	49	48	47	44,5	42	40	37	33	29
JET 300 T	3x230-400 V ~	2,5	2,2	3	8,5-4,9	-	-	(m)										

JETINOX



GENERAL DATA

Applications

Self-priming centrifugal pump with excellent suction capacity even when there are air bubbles and small particles of sand in the water.

Used especially for supplying water to domestic installations. Ideal for use in small-scale agriculture and gardening, limited industrial services and wherever self-priming operation is necessary.

Constructional features of the pump

Stainless steel pump body, seal cover and pressure disc.

Die-cast aluminium motor support.

Technopolymer impeller, diffuser and Venturi tube.

Carbon/ceramic mechanical seal.

Constructional features of the motor

Induction motor, closed and cooled with external ventilation.

Rotor mounted on oversized greased sealed-for-life ball bearings to ensure silent running and long life.

Built-in thermal and current overload protection and a capacitor permanently in circuit in the single-phase version.

Three-phase motors should be protected with a suitable overload protection complying with the regulations in force.

Manufactured according to CEI 2-3 and CEI 61-69 standards (EN 60335-2-41).

Motor protection: IP 44

Terminal box protection: IP 55

Insulation class: F

Standard voltage: single-phase 220-240 V/50 Hz

three-phase 230-400 V/50 Hz

TECHNICAL DATA

N.	PARTS*	MATERIALS
1	PUMP BODY	STAINLESS STEEL AISI 304 X5 CRNi 1810 - UNI 6900/71
4	IMPELLER	TECHNOPOLYMER A
7	SHAFT WITH ROTOR	STAINLESS STEEL AISI 303 X10 CRNiS 1809 - UNI 6900/71
16	MECHANICAL SEAL	CARBON/CERAMIC
28	OR GASKET	NBR RUBBER
36	SEAL COVER	STAINLESS STEEL AISI 304 X5 CRNi 1810 - UNI 6900/71
160	NOZZLE-VENTURI DIFFUSER ASSEMBLY	TECHNOPOLYMER A

* In contact with the liquid.

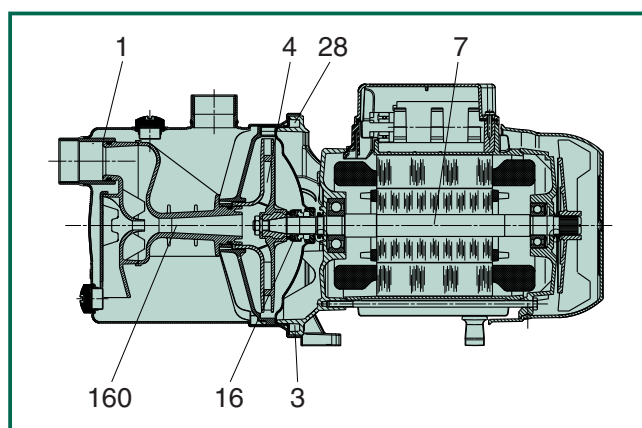

Self priming capacity

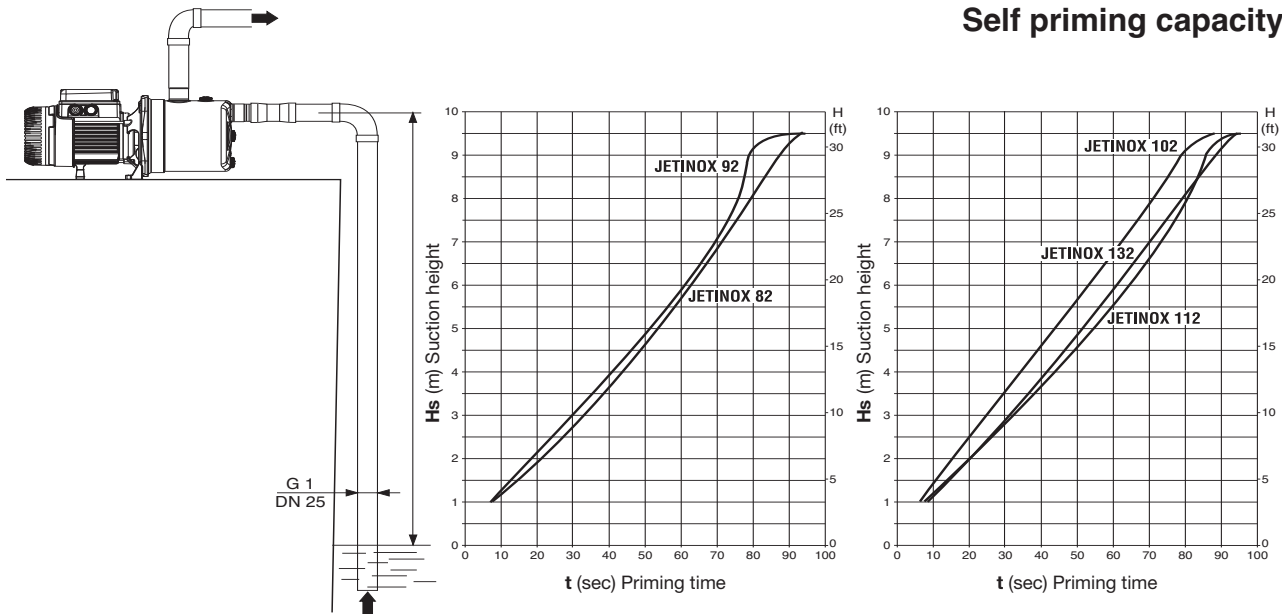

- Operating range: from 0.6 to 5.4 m³/h with head up to 61 metres
- Liquid quality requirements: clean, free from solids or abrasive substances, non viscous, non aggressive, non crystallized, chemically neutral, close to the characteristics of water.
- Liquid temperature range: from 0°C to +35°C for domestic use (EN 60335-2-41)
from 0°C to +40°C for other uses
- Maximum suction depth: 8 metres
- Maximum ambient temperature: **+50°C**
- Maximum operating pressure: 8 bar (800 kPa)
- Installation: fixed or portable in a horizontal position
- Special executions on request: other voltages and/or frequencies

The performance curves are based on the kinematic viscosity values = 1 mm²/s and density equal to 1000 kg/m³. Curve tolerance according to ISO 9906.
Liquid temperature range: from 0 °C to +35°C Maximum ambient temperature: +50°C

JETINOX 82

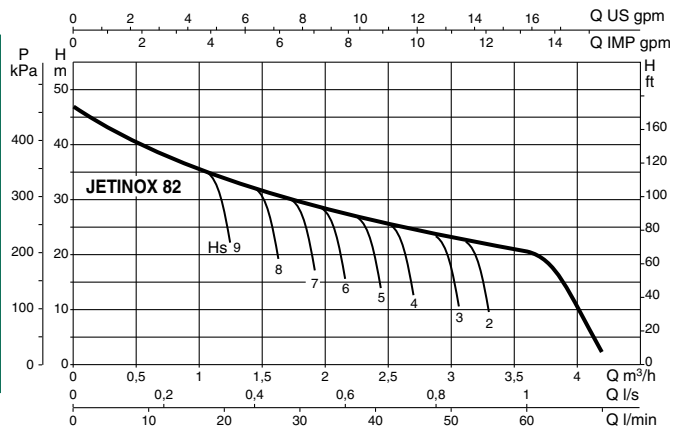
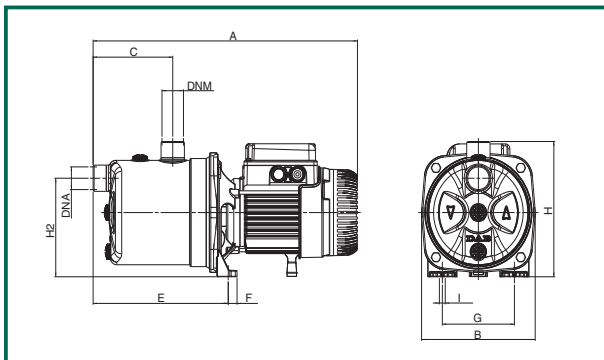

MODEL	A	B	C	E	F	G	H	H1	H2	I	L	DNA	DNM	PACKING DIMENSIONS			VOLUME	WEIGHT
														L/A	L/B	H	m ³	Kg
JETINOX 82	406	174	122	207	14	111	197	-	144	9	-	1" G	1" G	470	240	240	0,027	7,8

MODEL	ELECTRICAL DATA						HYDRAULIC DATA (n ≈ 2800 1/min)									
	VOLTAGE 50 Hz	P1 MAX kW	P2 NOMINAL		In A	CAPACITOR	Q	H								
			kW	HP		μF	Vc	m ³ /h	0	0,6	1,2	1,8	2,4	3	3,6	
								l/min	0	10	20	30	40	50	60	
JETINOX 82 M	1x220-240 V ~	0,85	0,6	0,8	3,8	12,5	450		H	47	40	34	30	26,2	23,5	20,3
JETINOX 82 T	3x230-400 V ~	0,86	0,6	0,8	2,8-1,6	-	-									

The performance curves are based on the kinematic viscosity values = 1 mm²/s and density equal to 1000 kg/m³. Curve tolerance according to ISO 9906.
Liquid temperature range: from 0 °C to +35°C Maximum ambient temperature: +50°C

JETINOX 102

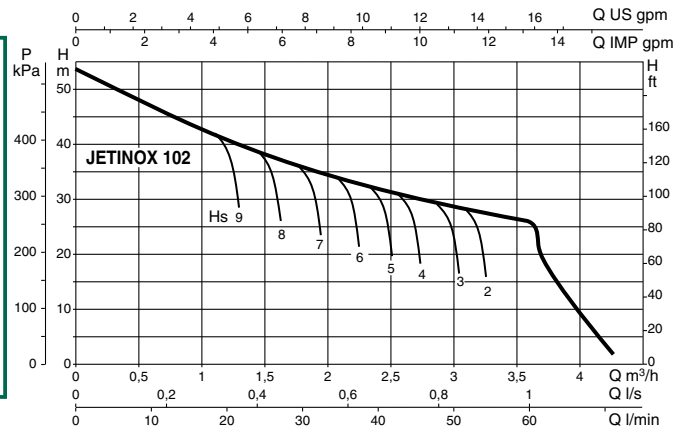
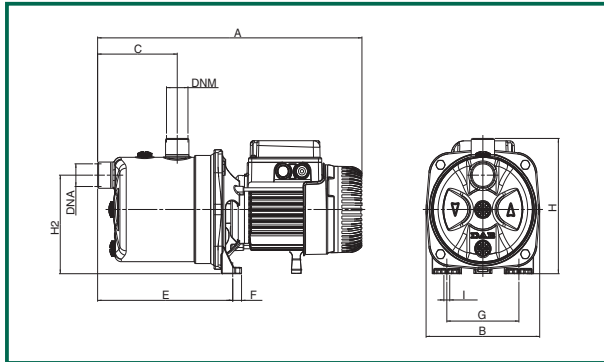

MODEL	A	B	C	E	F	G	H	H1	H2	I	L	DNA	DNM	PACKING DIMENSIONS			VOLUME m ³	WEIGHT Kg
														L/A	L/B	H		
JETINOX 102	424	174	122	207	14	111	197	-	144	9	-	1" G	1" G	470	240	240	0,027	9,6

MODEL	ELECTRICAL DATA						HYDRAULIC DATA (n = 2800 1/min)								
	VOLTAGE 50 Hz	P1 MAX kW	P2 NOMINAL		In A	CAPACITOR		Q m ³ /h l/min	0	0,6 10	1,2 20	1,8 30	2,4 40	3 50	3,6 60
			kW	HP		μF	Vc								
JETINOX 102 M	1x220-240 V ~	1,13	0,75	1	5,1	16	450	H (m)	53,8	47	41	36,3	32,4	28,8	25,8
JETINOX 102 T	3x230-400 V ~	1,04	0,75	1	3,3-1,9	-	-								

Liquid temperature range: from 0 °C to +35°C

Maximum ambient temperature: +50°C

JETINOX 112

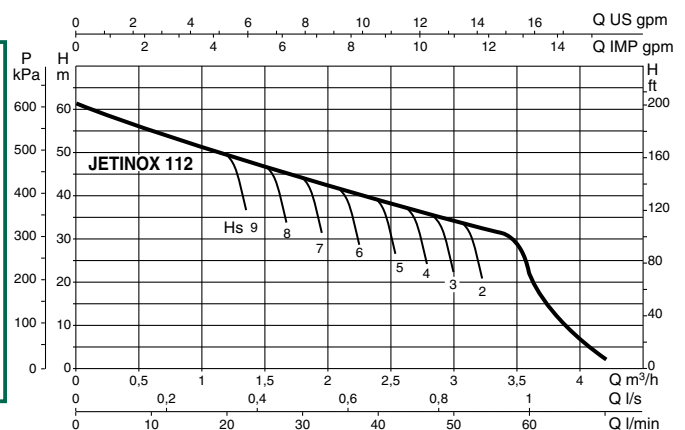
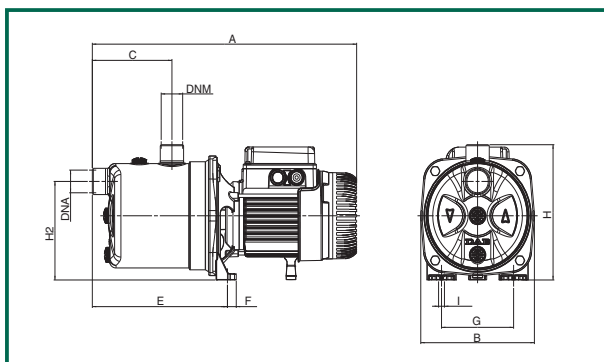

MODEL	A	B	C	E	F	G	H	H1	H2	I	L	DNA	DNM	PACKING DIMENSIONS			VOLUME m ³	WEIGHT Kg
														L/A	L/B	H		
JETINOX 112	424	174	122	207	14	111	197	-	144	9	-	1" G	1" G	470	240	240	0,027	10,6

MODEL	ELECTRICAL DATA						HYDRAULIC DATA (n = 2800 1/min)								
	VOLTAGE 50 Hz	P1 MAX kW	P2 NOMINAL		In A	CAPACITOR		Q m ³ /h l/min	0	0,6 10	1,2 20	1,8 30	2,4 40	3 50	3,6 60
			kW	HP		μF	Vc								
JETINOX 112 M	1x220-240 V ~	1,4	1	1,36	6,2	25	450	H (m)	61	54	47,8	42,8	38,8	34,8	20
JETINOX 112 T	3x230-400 V ~	1,35	1	1,36	4,3-2,5	-	-								

The performance curves are based on the kinematic viscosity values = 1 mm²/s and density equal to 1000 kg/m³. Curve tolerance according to ISO 9906.
 Liquid temperature range: from 0 °C to +35°C Maximum ambient temperature: +50°C

JETINOX 92

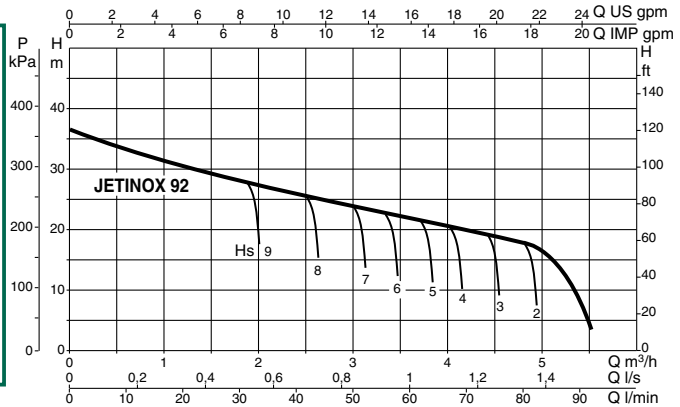
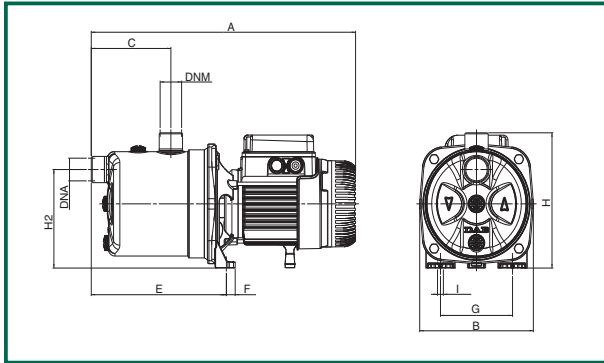

MODEL	A	B	C	E	F	G	H	H1	H2	I	L	DNA	DNM	PACKING DIMENSIONS			VOLUME	WEIGHT
														L/A	L/B	H	m ³	Kg
JETINOX 92	406	174	122	207	14	111	197	–	144	9	–	1" G	1" G	470	240	240	0,027	8,8

MODEL	ELECTRICAL DATA						HYDRAULIC DATA (n ≈ 2800 1/min)											
	VOLTAGE 50 Hz	P1 MAX kW	P2 NOMINAL		In A	CAPACITOR	Q	0	0,6	1,2	1,8	2,4	3	3,6	4,2	4,8	H (m)	
			kW	HP		μF	Vc	m ³ /h	l/min	10	20	30	40	50	60	70		80
JETINOX 92 M	1x220-240 V ~	0,94	0,75	1	4,2	14	450											
JETINOX 92 T	3x230-400 V ~	0,93	0,75	1	3,3-1,9	–	–											

Liquid temperature range: from 0 °C to +35°C

Maximum ambient temperature: +50°C

JETINOX 132

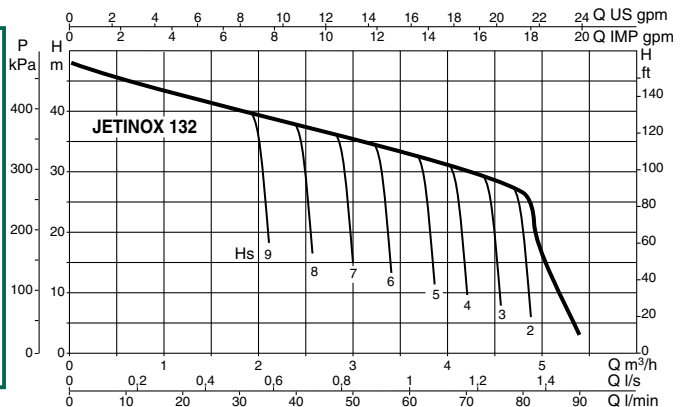
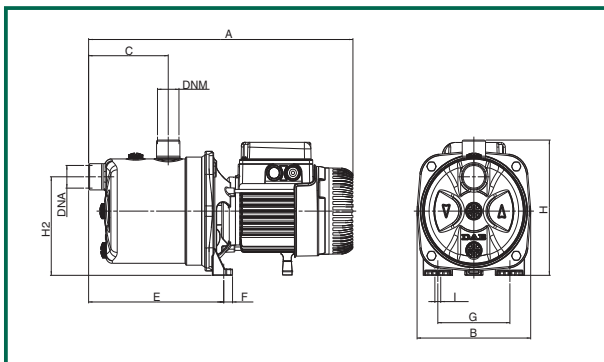

MODEL	A	B	C	E	F	G	H	H1	H2	I	L	DNA	DNM	PACKING DIMENSIONS			VOLUME	WEIGHT
														L/A	L/B	H	m ³	Kg
JETINOX 132	424	174	122	207	14	111	197	–	144	9	–	1" G	1" G	470	240	240	0,027	10,6

MODEL	ELECTRICAL DATA						HYDRAULIC DATA (n ≈ 2800 1/min)											
	VOLTAGE 50 Hz	P1 MAX kW	P2 NOMINAL		In A	CAPACITOR	Q	0	0,6	1,2	1,8	2,4	3	3,6	4,2	4,8	H (m)	
			kW	HP		μF	Vc	m ³ /h	l/min	10	20	30	40	50	60	70		80
JETINOX 132 M	1x220-240 V ~	1,49	1	1,36	6,6	25	450											
JETINOX 132 T	3x230-400 V ~	1,43	1	1,36	4,7-2,7	–	–											

JETCOM



GENERAL DATA

Applications

Self-priming centrifugal pump with excellent suction capacity even when there are air bubbles and small particles of sand in the water.

Used especially for supplying water to domestic installations. Ideal for use in small-scale agriculture and gardening, limited industrial services and wherever self-priming operation is necessary.

Constructional features of the pump

Technopolymer pump body and die-cast aluminium motor support.

Technopolymer impeller, diffuser, Venturi tube and sand guard.

Stainless steel pressure disc.

Carbon/ceramic mechanical seal.

Constructional features of the motor

Induction motor, closed and cooled with external ventilation.

Rotor mounted on oversized greased sealed-for-life ball bearings to ensure silent running and long life.

Built-in thermal and current overload protection and a capacitor permanently in circuit in the single-phase version.

Three-phase motors should be protected with a suitable overload protection complying with the regulations in force.

Manufactured according to CEI 2-3 and CEI 61-69 standards (EN 60335-2-41).

Motor protection: IP 44

Terminal box protection: IP 55

Insulation class: F

Standard voltage: single-phase 220-240 V/50 Hz

 three-phase 230-400 V/50 Hz

TECHNICAL DATA

N.	PARTS*	MATERIALS
1	PUMP BODY	TECHNOPOLYMER A
4	IMPELLER	TECHNOPOLYMER A
7	SHAFT WITH ROTOR	STAINLESS STEEL AISI 416 X12 CrS13 - UNI 6900/71
16	MECHANICAL SEAL	CARBON/CERAMIC
28	OR GASKET	NBR RUBBER
36	SEAL COVER	STAINLESS STEEL AISI 304 X5 CRNi 1810 - UNI 6900/71
160	NOZZLE-VENTURI DIFFUSER ASSEMBLY	TECHNOPOLYMER A

* In contact with the liquid.

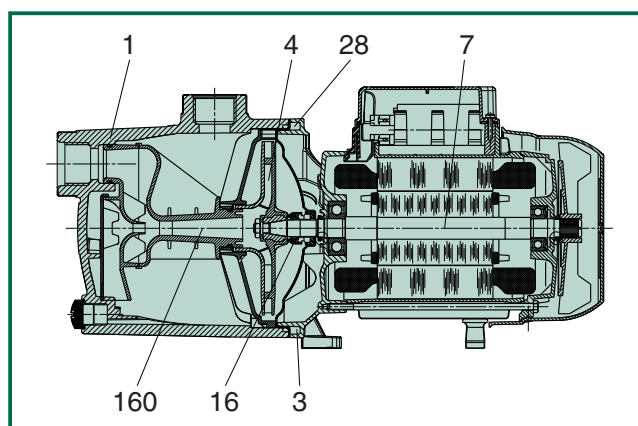

Self priming capacity

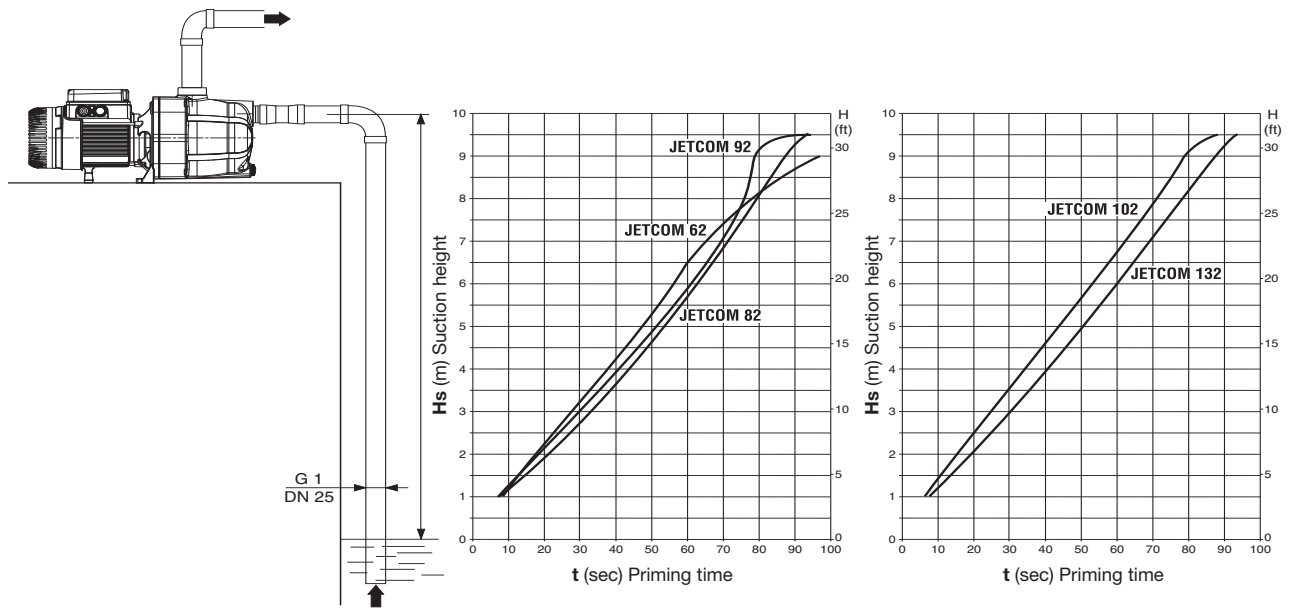

- Operating range: from 0.6 to 5.4 m³/h with head up to 54 metres
- Liquid quality requirements: clean, free from solids or abrasive substances, non viscous, non aggressive, non crystallized, chemically neutral, close to the characteristics of water.
- Liquid temperature range: from 0°C to +35°C for domestic use (EN 60335-2-41) from 0°C to +40°C for other uses
- Maximum suction depth: 8 metres
- Maximum ambient temperature: +40°C
- Maximum operating pressure: 6 bar (600 kPa)
- Installation: fixed or portable in a horizontal position
- Special executions on request: other voltages and/or frequencies

The performance curves are based on the kinematic viscosity values = 1 mm²/s and density equal to 1000 kg/m³. Curve tolerance according to ISO 9906.
 Liquid temperature range: from 0 °C to +35°C Maximum ambient temperature: +40°C

JETCOM 62

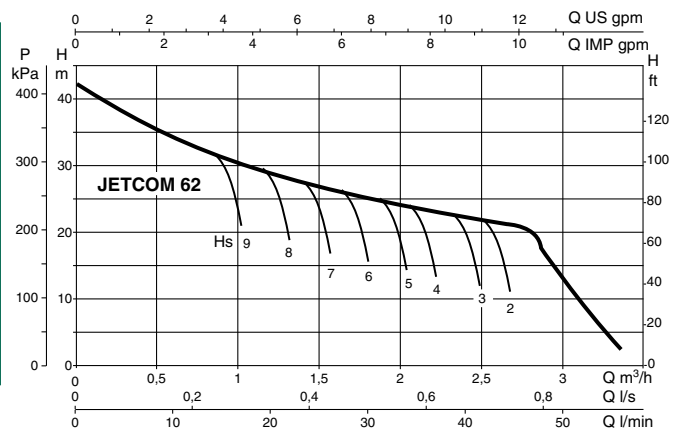
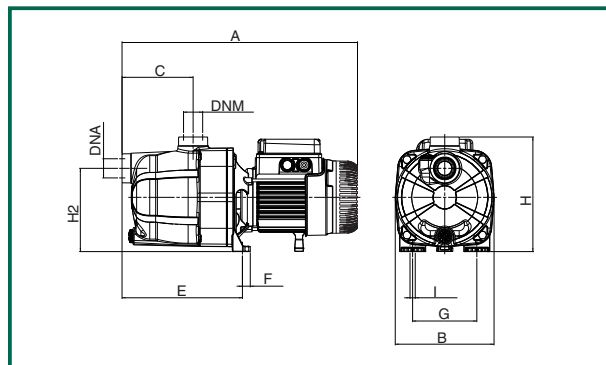

MODEL	A	B	C	E	F	G	H	H1	H2	I	L	DNA	DNM	PACKING DIMENSIONS			VOLUME	WEIGHT
														L/A	L/B	H	m ³	Kg
JETCOM 62	406	170	122	208	14	111	198	-	144	9	-	1" G	1" G	470	240	240	0,027	7,5

MODEL	ELECTRICAL DATA						HYDRAULIC DATA (n ≈ 2800 1/min)								
	VOLTAGE 50 Hz	P1 MAX kW	P2 NOMINAL		In A	CAPACITOR	Q	0	0,6	1,2	1,8	2,4	2,7	3,6	
			kW	HP		μF	Vc	l/min	0	10	20	30	40	45	60
JETCOM 62 M	1x220-240 V ~	0,72	0,44	0,6	3,12	12,5	450	H	42	35	29,2	25,6	22,9	21,1	-
JETCOM 62 T	3x230-400 V ~	0,67	0,44	0,6	2,1-1,2	-	-								

The performance curves are based on the kinematic viscosity values = 1 mm²/s and density equal to 1000 kg/m³. Curve tolerance according to ISO 9906.
Liquid temperature range: from 0 °C to +35°C Maximum ambient temperature: +40°C

JETCOM 82

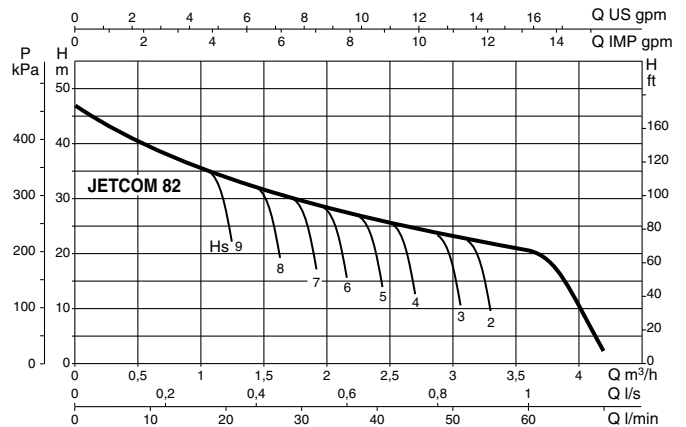
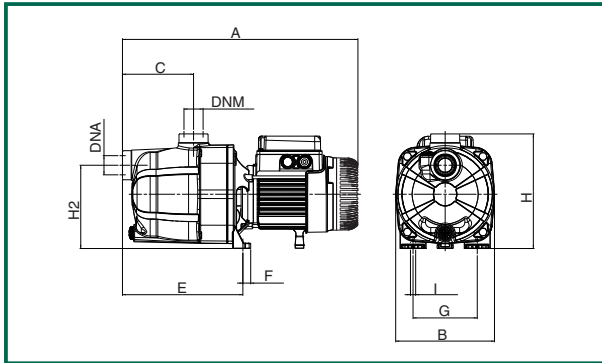

MODEL	A	B	C	E	F	G	H	H1	H2	I	L	DNA	DNM	PACKING DIMENSIONS			VOLUME m ³	WEIGHT Kg
														L/A	L/B	H		
JETCOM 82	406	170	122	208	14	111	198	-	144	9	-	1" G	1" G	470	240	240	0,027	7,7

MODEL	ELECTRICAL DATA						HYDRAULIC DATA (n ≈ 2800 1/min)								
	VOLTAGE 50 Hz	P1 MAX kW	P2 NOMINAL		In A	CAPACITOR	Q								
			kW	HP			μF	Vc	m ³ /h	l/min	0	0,6	1,2	1,8	2,4
JETCOM 82 M	1x220-240 V ~	0,85	0,6	0,8	3,8	12,5	450	H	47	40	34	30	26,2	23,5	20,3
JETCOM 82 T	3x230-400 V ~	0,86	0,6	0,8	2,8-1,6	-	-								

Liquid temperature range: from 0 °C to +35°C

Maximum ambient temperature: +40°C

JETCOM 102

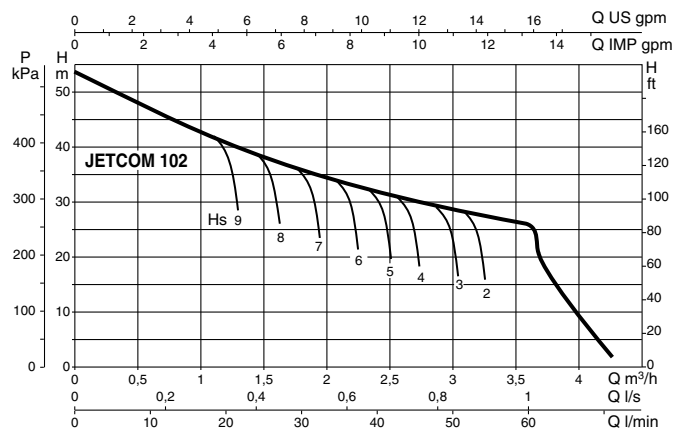
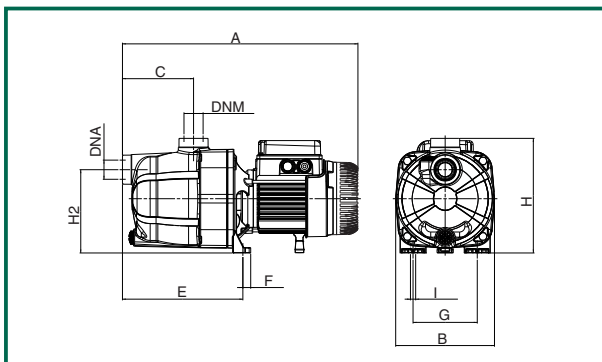

MODEL	A	B	C	E	F	G	H	H1	H2	I	L	DNA	DNM	PACKING DIMENSIONS			VOLUME m ³	WEIGHT Kg
														L/A	L/B	H		
JETCOM 102	425	170	122	208	14	111	203	-	144	9	-	1" G	1" G	470	240	240	0,027	9,5

MODEL	ELECTRICAL DATA						HYDRAULIC DATA (n ≈ 2800 1/min)								
	VOLTAGE 50 Hz	P1 MAX kW	P2 NOMINAL		In A	CAPACITOR	Q								
			kW	HP			μF	Vc	m ³ /h	l/min	0	0,6	1,2	1,8	2,4
JETCOM 102 M	1x220-240 V ~	1,13	0,75	1	5,1	16	450	H	53,8	47	41	36,3	32,4	28,8	25,8
JETCOM 102 T	3x230-400 V ~	1,04	0,75	1	3,3-1,9	-	-								

The performance curves are based on the kinematic viscosity values = 1 mm²/s and density equal to 1000 kg/m³. Curve tolerance according to ISO 9906.
 Liquid temperature range: from 0 °C to +35°C Maximum ambient temperature: +40°C

JETCOM 92

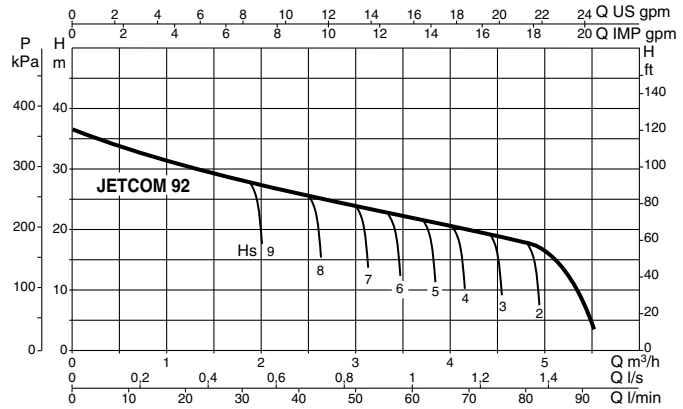
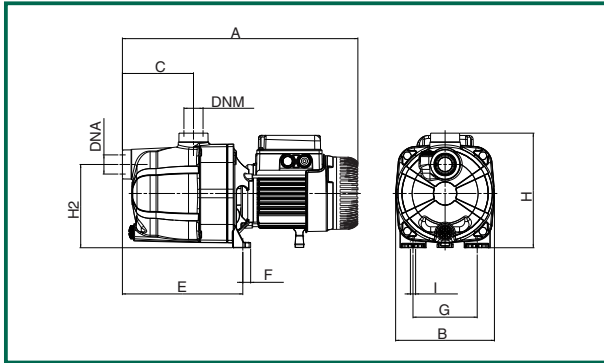

MODEL	A	B	C	E	F	G	H	H1	H2	I	L	DNA	DNM	PACKING DIMENSIONS			VOLUME	WEIGHT
														L/A	L/B	H	m ³	Kg
JETCOM 92	425	170	122	208	14	111	203	-	144	9	-	1" G	1" G	470	240	240	0,027	8,7

MODEL	ELECTRICAL DATA						HYDRAULIC DATA (n = 2800 1/min)										
	VOLTAGE 50 Hz	P1 MAX kW	P2 NOMINAL		In A	CAPACITOR		Q									
			kW	HP		μF	Vc	m ³ /h	0	0,6	1,2	1,8	2,4	3	3,6	4,2	4,8
JETCOM 92 M	1x220-240 V ~	0,94	0,75	1	4,2	14	450	H	36,2	33,5	31	28,4	26	24	21,8	19,6	17
JETCOM 92 T	3x230-400 V ~	0,93	0,75	1	3,3-1,9	-	-										

Liquid temperature range: from 0 °C to +35°C

Maximum ambient temperature: +40°C

JETCOM 132

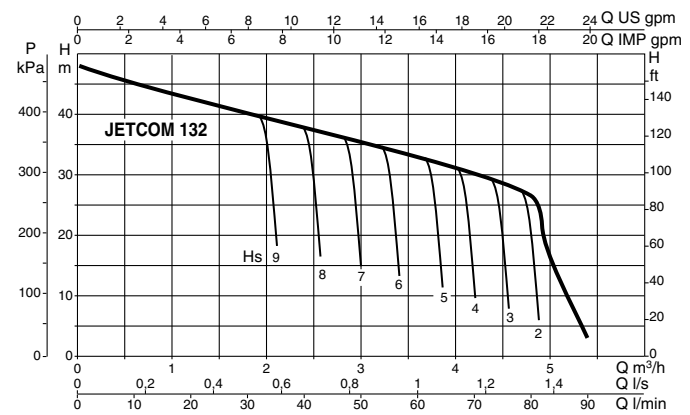
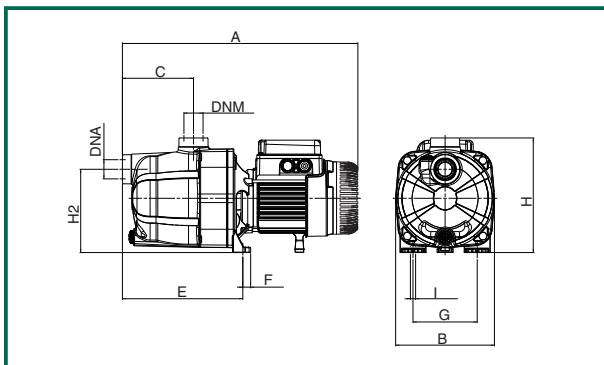

MODEL	A	B	C	E	F	G	H	H1	H2	I	L	DNA	DNM	PACKING DIMENSIONS			VOLUME	WEIGHT
														L/A	L/B	H	m ³	Kg
JETCOM 132	425	170	122	208	14	111	203	-	144	9	-	1" G	1" G	470	240	240	0,027	10,5

MODEL	ELECTRICAL DATA						HYDRAULIC DATA (n = 2800 1/min)										
	VOLTAGE 50 Hz	P1 MAX kW	P2 NOMINAL		In A	CAPACITOR		Q									
			kW	HP		μF	Vc	m ³ /h	0	0,6	1,2	1,8	2,4	3	3,6	4,2	4,8
JETCOM 132 M	1x220-240 V ~	1,49	1	1,36	6,6	25	450	H	48	45,6	42,8	40	37,6	35	32,5	30	27
JETCOM 132 T	3x230-400 V ~	1,43	1	1,36	4,7-2,7	-	-										

EURO



GENERAL DATA

Applications

Multistage horizontal centrifugal pump, featuring extremely silent running suitable for domestic use for water supply and pressurization, irrigation of gardens and vegetable gardens, and for moving water in general.

Construction features of pump:

Pump body in 200 UNI ISO 185 cast iron. Motor support in die-cast aluminium, seal holder in AISI 304 steel. Mechanical seal in carbon/ceramic. Rotor shaft in AISI 304 steel. Impellers, diffuser bodies and diffusers in technopolymer. Wear rings in stainless steel.

Construction features of motor

Continuous service asynchronous motor.

Incorporated thermal current protection and capacitor permanently in circuit in the single-phase version.

The user must provide overload protection for the three-phase version.

Protection level of motor: IP 44

Protection level of terminal board: IP 55

Insulation class: F

Standard voltage: Single-phase 220/240V - 50 Hz - 2 poles
Three-phase 230/400V - 50 Hz - 2 poles

TECHNICAL DATA

N.	PARTS	MATERIALS
1	PUMP BODY	200 CAST IRON UNI ISO 185
4	IMPELLER	TECHNOPOLYMER
6	DIFFUSER	TECHNOPOLYMER
7	SHAFT WITH ROTOR	AISI 304 X5CRNI 1810 UNI 6900/71 STAINLESS STEEL
16	MECHANICAL SEAL	CARBON/CERAMIC
28	GASKET OR	NBR
36	SEAL HOLDER COVER	AISI 304 X5CRNI 1810 UNI 6900/71 STAINLESS STEEL
98	DIFFUSER BODY	TECHNOPOLYMER
304	REAR DISK	TECHNOPOLYMER

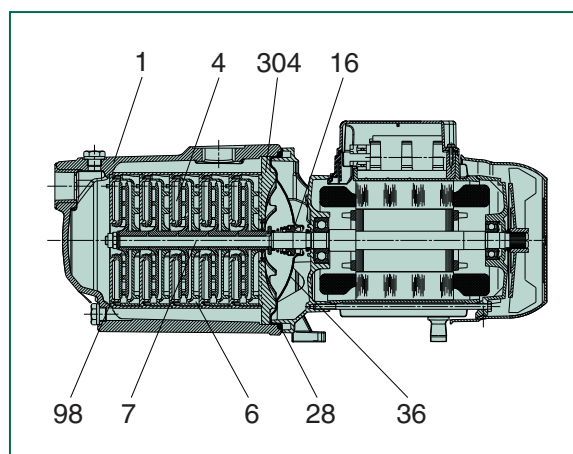

- Operating range: from 10 to 120 l/min. with a head of up to 72 m.
- Pumped liquid characteristics: clean, free from solid or abrasive substances, not viscous, not aggressive, not crystallised, chemically neutral and close to the characteristics of water.
- Liquid temperature range: from 0°C to +35°C for domestic use (EN 60335-2-41)
from 0°C to +40°C for other uses.
- Maximum ambient temperature: +40°C
- Maximum operating pressure: 8 bar (800 kPa)
- Installation: fixed or portable in a horizontal position

The performance curves are based on the kinematic viscosity values = 1 mm²/s and density equal to 1000 Kg/m³. Curve tolerance according to ISO 9906.
 Liquid temperature range: from 0 °C to +35°C Maximum ambient temperature: +40°C

EURO 30

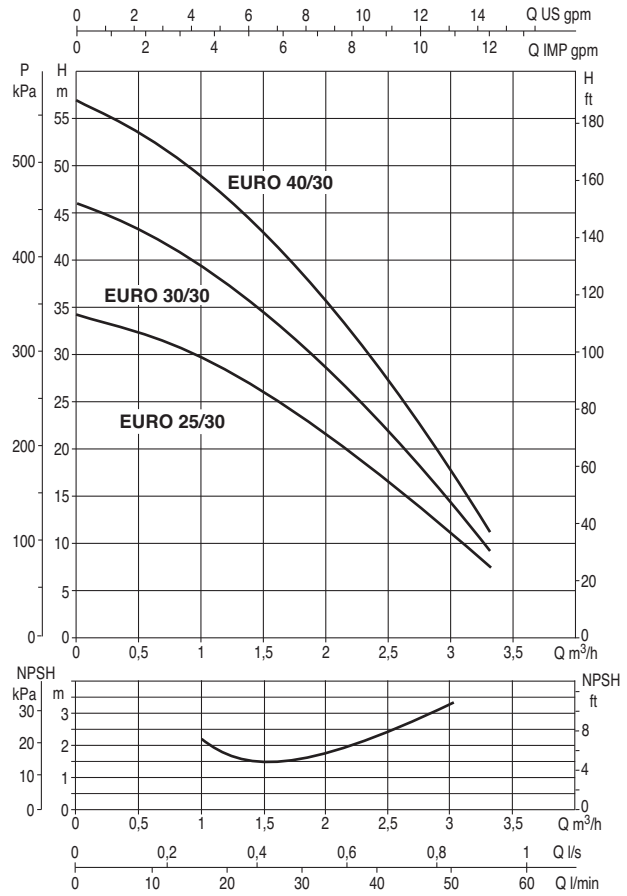
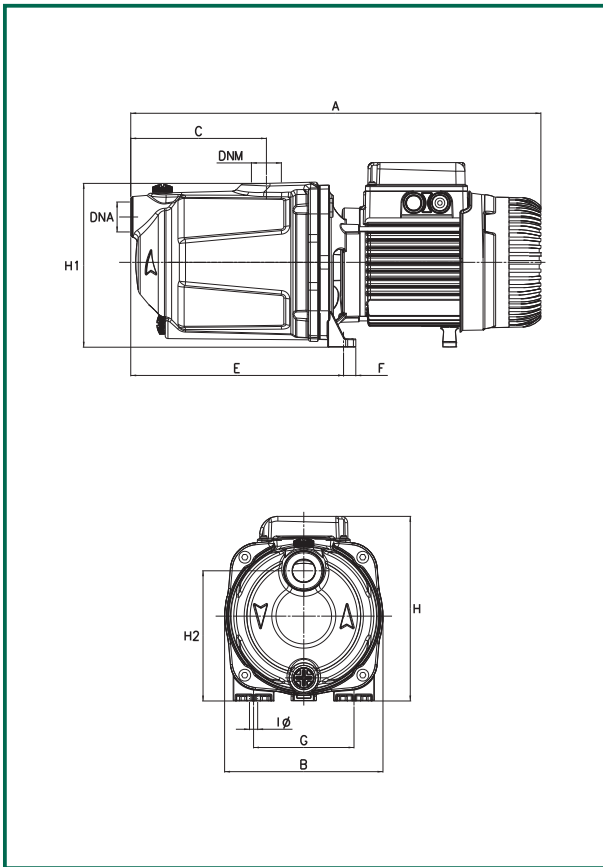

MODEL	A	B	C	E	F	G	I Ø	H	H1	H2	DNA	DNM	PACKING DIMENSIONS			VOLUME m ³	WEIGHT Kg	
													L/A	L/B	H		M	T
EURO 25/30 MT	378	175	94,5	180	13,5	111	9	194	179	143,5	1" G	1" G	440	206	245	0,025	10,7	10,5
EURO 30/30 MT	433	175	149,5	235	13,5	111	9	194	179	143,5	1" G	1" G	480	212	265	0,031	12,7	12,5
EURO 40/30 MT	433	175	149,5	235	13,5	111	9	194	179	143,5	1" G	1" G	480	212	265	0,031	12,8	12,7

MODEL	ELECTRICAL DATA								HYDRAULIC DATA (n = 2800 1/min)							
	N° IMPELLER	VOLTAGE 50 Hz	P1 MAX kW	P2 NOMINAL		In A	CAPACITOR		Q m ³ /h l/min	H (m)						
				kW	HP		µF	Vc		0	0,6	1,2	1,8	2,4	3	3,3
EURO 25/30 M	3	1x220-240 V ~	0,520	0,37	0,5	2,4	10	450	H (m)	34,4	31,7	28,3	23,5	17,5	11	8
EURO 25/30 T		3x230-400 V ~	0,510	0,37	0,5	1,9-1,1	-	-		46	42,2	37,8	31,2	23,3	14,3	10
EURO 30/30 M	4	1x220-240 V ~	0,72	0,44	0,6	4	12,5	450		57	52,7	47	38,8	29	17,7	12
EURO 30/30 T		3x230-400 V ~	0,7	0,44	0,6	2,65-1,53	-	-								
EURO 40/30 M	5	1x220-240 V ~	0,880	0,55	0,75	3,9	12,5	450								
EURO 40/30 T		3x230-400 V ~	0,870	0,55	0,75	2,8-1,6	-	-								

The performance curves are based on the kinematic viscosity values = 1 mm²/s and density equal to 1000 Kg/m³. Curve tolerance according to ISO 9906.
 Liquid temperature range: from 0 °C to +35°C
 Maximum ambient temperature: +40°C

EURO 50

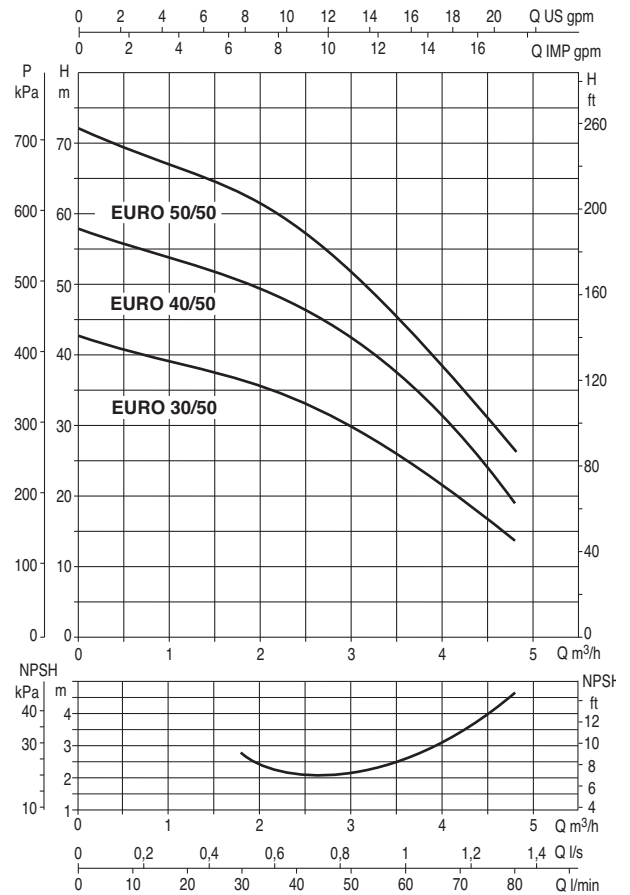
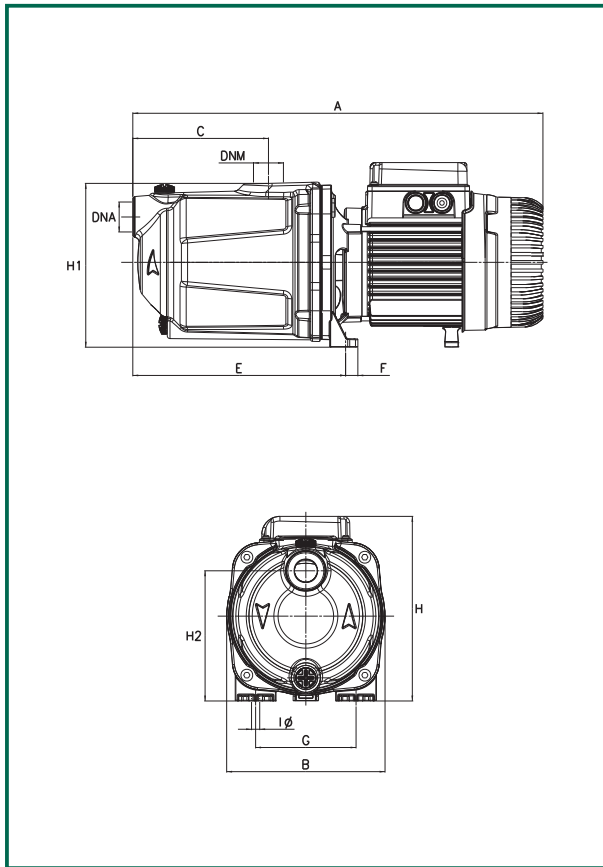

MODEL	A	B	C	E	F	G	I Ø	H	H1	H2	DNA	DNM	PACKING DIMENSIONS			VOLUME m ³	WEIGHT Kg	
													L/A	L/B	H		M	T
EURO 30/50 MT	378	175	94,5	180	13,5	111	9	194	179	143,5	1" G	1" G	440	206	245	0,025	11,5	11,3
EURO 40/50 MT	452	175	149,5	235	13,5	111	9	204	179	143,5	1" G	1" G	480	212	265	0,031	15,6	15,4
EURO 50/50 MT	452	175	149,5	235	13,5	111	9	204	179	143,5	1" G	1" G	480	212	265	0,031	16,3	15,9

MODEL	ELECTRICAL DATA								HYDRAULIC DATA (n ≈ 2800 1/min)											
	N° IMPELLER	VOLTAGE 50 Hz	P1 MAX kW	P2 NOMINAL		In A	CAPACITOR		Q m ³ /h l/min	H (m)										
				kW	HP		µF	Vc		0	0,6	1,2	1,8	2,4	3	3,3	3,6	4,2	4,8	
EURO 30/50 M	3	1x220-240 V ~	0,880	0,55	0,75	3,9	12,5	450	H (m)	42,5	40,2	38,2	36,2	33,8	30	27,5	24,8	19,5	14	
EURO 30/50 T		3x230-400 V ~	0,870	0,55	0,75	2,8-1,6	-	-		57,5	55,3	52,8	50,1	47,1	42,7	39,5	35,8	28	19	
EURO 40/50 M	4	1x220-240 V ~	1,200	0,75	1	5,3	25	450		72	68,5	65,5	62,1	58,2	52,2	48	43,6	34,5	26	
EURO 40/50 T		3x230-400 V ~	1,180	0,75	1	3,8-2,2	-	-												
EURO 50/50 M	5	1x220-240 V ~	1,480	1	1,36	6,3	25	450												
EURO 50/50 T		3x230-400 V ~	1,440	1	1,36	4,4-2,5	-	-												

The performance curves are based on the kinematic viscosity values = 1 mm²/s and density equal to 1000 Kg/m³. Curve tolerance according to ISO 9906.
 Liquid temperature range: from 0 °C to +35°C Maximum ambient temperature: +40°C

EURO 80

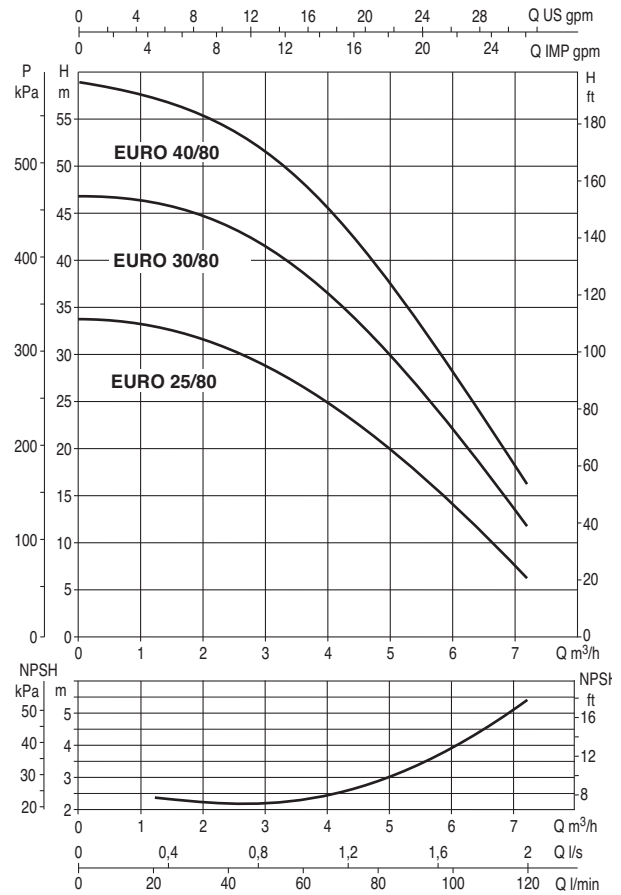
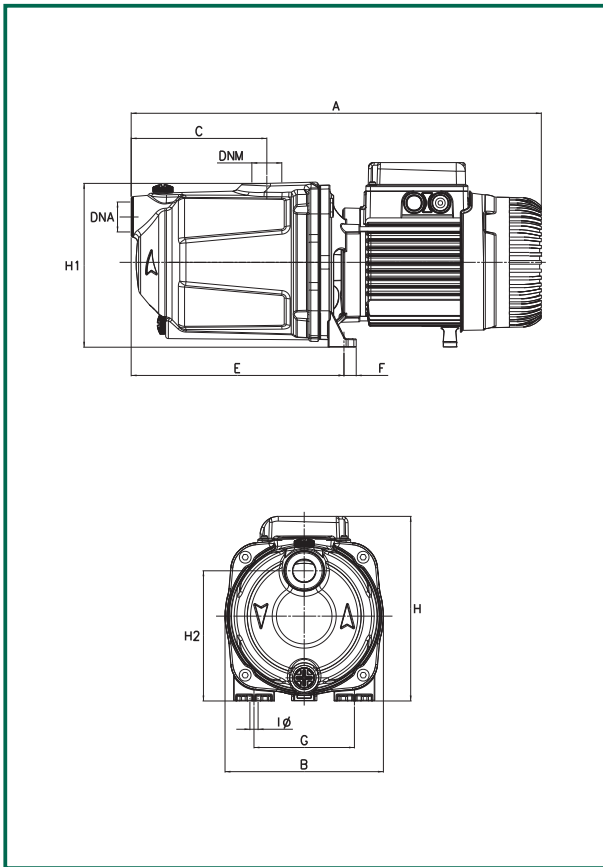

MODEL	A	B	C	E	F	G	I Ø	H	H1	H2	DNA	DNM	PACKING DIMENSIONS			VOLUME m ³	WEIGHT Kg	
													L/A	L/B	H		M	T
EURO 25/80 MT	378	175	94,5	180	13,5	111	9	194	179	143,5	1" G	1" G	440	206	245	0,025	11,5	11,3
EURO 30/80 MT	452	175	149,5	235	13,5	111	9	204	179	143,5	1" G	1" G	480	212	265	0,031	15,6	15,4
EURO 40/80 MT	452	175	149,5	235	13,5	111	9	204	179	143,5	1" G	1" G	480	212	265	0,031	16,3	15,9

MODEL	ELECTRICAL DATA								HYDRAULIC DATA (n = 2800 1/min)														
	N° IMPELLER	VOLTAGE 50 Hz	P1 MAX kW	P2 NOMINAL kW	HP	In A	CAPACITOR		Q														
							µF	Vc	m ³ /h	0	0,6	1,2	1,8	2,4	3	3,3	3,6	4,2	4,8	6	7,2		
EURO 25/80 M	3	1x220-240 V ~	0,880	0,55	0,75	3,9	12,5	450	H (m)	34	33,7	33,2	32	30,5	28,7	27,5	26	23,9	21	14,5	6,3		
EURO 25/80 T		3x230-400 V ~	0,870	0,55	0,75	2,8-1,6	-	-		47,3	47	46,3	45,2	43,5	41	39,9	38	34,8	31	23	12		
EURO 30/80 M	4	1x220-240 V ~	1,200	0,8	1,1	5,3	20	450		59	58	57	56	54	51	49,5	47,5	43,8	39,5	29,5	16		
EURO 30/80 T		3x230-400 V ~	1,180	0,8	1,1	3,8-2,2	-	-															
EURO 40/80 M	5	1x220-240 V ~	1,480	1	1,36	6,3	25	450															
EURO 40/80 T		3x230-400 V ~	1,440	1	1,36	4,4-2,5	-	-															

EUROINOX

Self-priming



GENERAL DATA

Applications

Self-priming multistage horizontal centrifugal pump, featuring extremely silent running suitable for domestic use for water supply and pressurization, irrigation of gardens and vegetable gardens, and for moving water in general.

Construction features of pump:

Pump body in stainless steel AISI 304. Motor support in die-cast aluminium, seal holder in AISI 304 steel. Mechanical seal in carbon/ceramic. Rotor shaft in AISI 304 steel. Impellers, diffuser bodies and diffusers in technopolymer. Wear rings in stainless steel.

Construction features of motor

Continuous service asynchronous motor.

Incorporated thermal current protection and capacitor permanently in circuit in the single-phase version.

The user must provide overload protection for the three-phase version.

Protection level of motor: IP 44

Protection level of terminal board: IP 55

Insulation class: F

Standard voltage: Single-phase 220/240V - 50 Hz - 2 poles

Three-phase 230/400V - 50 Hz - 2 poles

TECHNICAL DATA

N.	PARTS	MATERIALS
1	PUMP BODY	AISI 304 X5CRNI 1810 UNI 6900/71 STAINLESS STEEL
4	IMPELLER	TECHNOPOLYMER
6	DIFFUSER	TECHNOPOLYMER
7	SHAFT WITH ROTOR	AISI 304 X5CRNI 1810 UNI 6900/71 STAINLESS STEEL
16	MECHANICAL SEAL	CARBON/CERAMIC
28	GASKET OR	NBR
36	SEAL HOLDER COVER	AISI 304 X5CRNI 1810 UNI 6900/71 STAINLESS STEEL
98	DIFFUSER BODY	TECHNOPOLYMER
304	REAR DISK	TECHNOPOLYMER
305	FRONT DISK	TECHNOPOLYMER

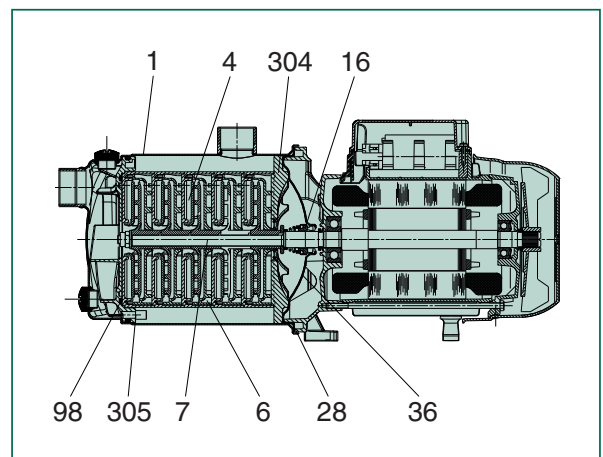

- Operating range: from 10 to 120 l/min. with a head of up to 72 m.
- Pumped liquid characteristics: clean, free from solid or abrasive substances, not viscous, not aggressive, not crystallised, chemically neutral and close to the characteristics of water.
- Liquid temperature range: from 0°C to +35°C for domestic use (EN 60335-2-41)
from 0°C to +40°C for other uses.
- Maximum ambient temperature: +40°C
- Maximum operating pressure: 8 bar (800 kPa)
- Installation: fixed or portable in a horizontal position

The performance curves are based on the kinematic viscosity values = 1 mm²/s and density equal to 1000 Kg/m³. Curve tolerance according to ISO 9906.
 Liquid temperature range: from 0 °C to +35°C
 Maximum ambient temperature: +40°C

EUROINOX 30

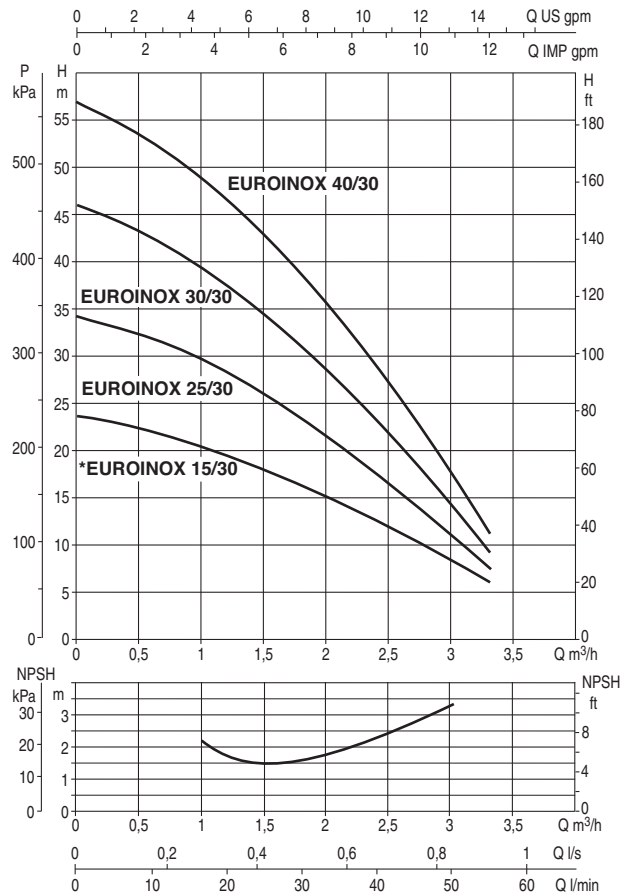
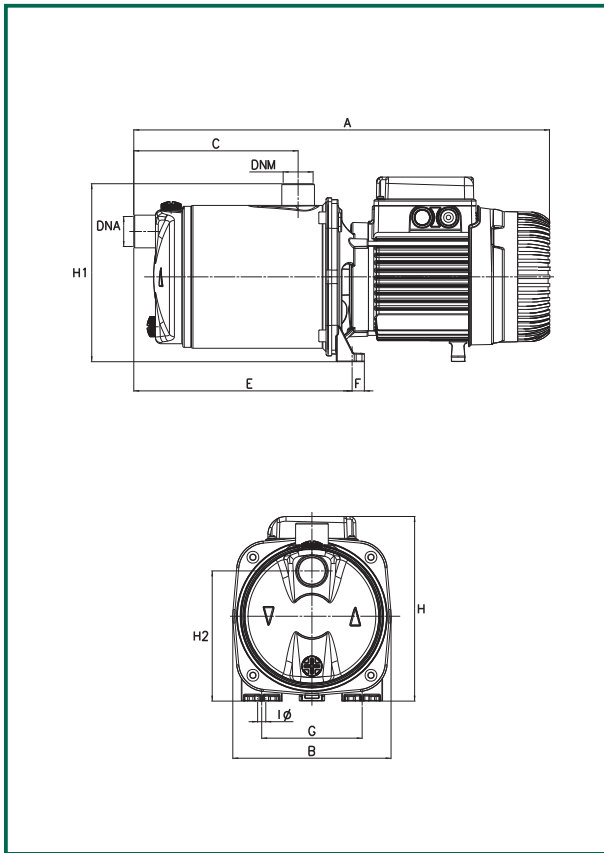

MODEL	A	B	C	E	F	G	I Ø	H	H1	H2	DNA	DNM	PACKING DIMENSIONS			VOLUME m ³	WEIGHT Kg	
													L/A	L/B	H		M	T
EUROINOX 25/30 MT	384	174	108	186	13,5	111	9	193	196	143	1" G	1" G	440	206	245	0,025	9,9	9,7
EUROINOX 30/30 MT	439	174	166	241	13,5	111	9	193	196	143	1" G	1" G	480	212	265	0,031	11,9	11,7
EUROINOX 40/30 MT	439	174	166	241	13,5	111	9	193	196	143	1" G	1" G	480	212	265	0,031	12	11,9

MODEL	ELECTRICAL DATA								HYDRAULIC DATA (n = 2800 1/min)																					
	N° IMPELLER	VOLTAGE 50 Hz	P1 MAX kW	P2		In A	CAPACITOR		Q																					
				NOMINAL kW	HP		µF	Vc	m ³ /h	0	0,6	1,2	1,8	2,4	3	3,3														
EUROINOX 25/30 M	3	1x220-240 V ~	0,520	0,37	0,5	2,4	10	450	H (m)	34,4	31,7	28,3	23,5	17,5	11	8														
EUROINOX 25/30 T		3x230-400 V ~	0,510	0,37	0,5	1,9-1,1	-	-																						
EUROINOX 30/30 M	4	1x220-240 V ~	0,72	0,44	0,6	3,5	12,5	450									46	42,2	37,8	31,2	23,3	14,3	10							
EUROINOX 30/30 T		3x230-400 V ~	0,7	0,44	0,6	2,7-1,5	-	-																						
EUROINOX 40/30 M	5	1x220-240 V ~	0,880	0,55	0,75	3,9	12,5	450																57	52,7	47	38,8	29	17,7	12
EUROINOX 40/30 T		3x230-400 V ~	0,870	0,55	0,75	2,8-1,6	-	-																						

* Available on request.

The performance curves are based on the kinematic viscosity values = 1 mm²/s and density equal to 1000 Kg/m³. Curve tolerance according to ISO 9906.
 Liquid temperature range: from 0 °C to +35°C Maximum ambient temperature: +40°C

EUROINOX 50

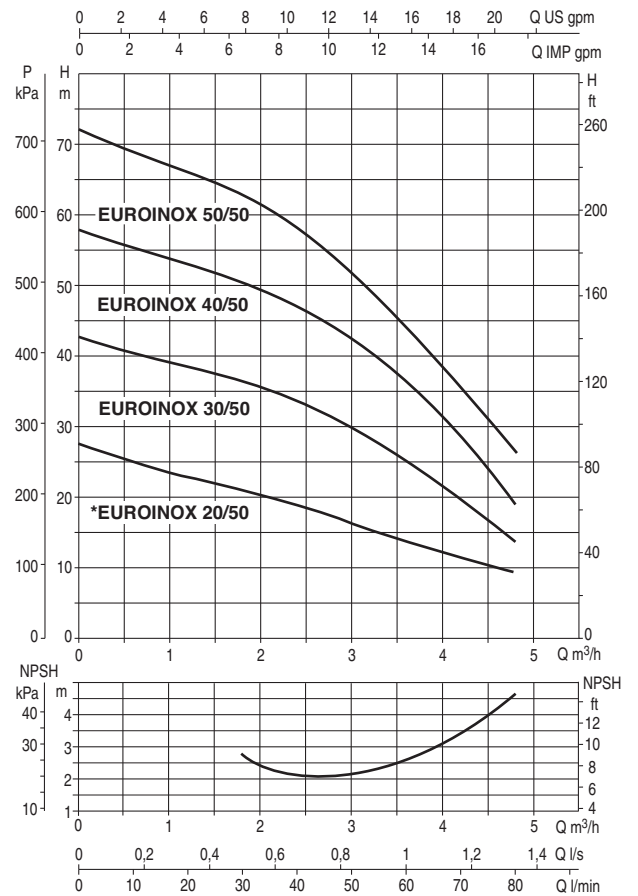
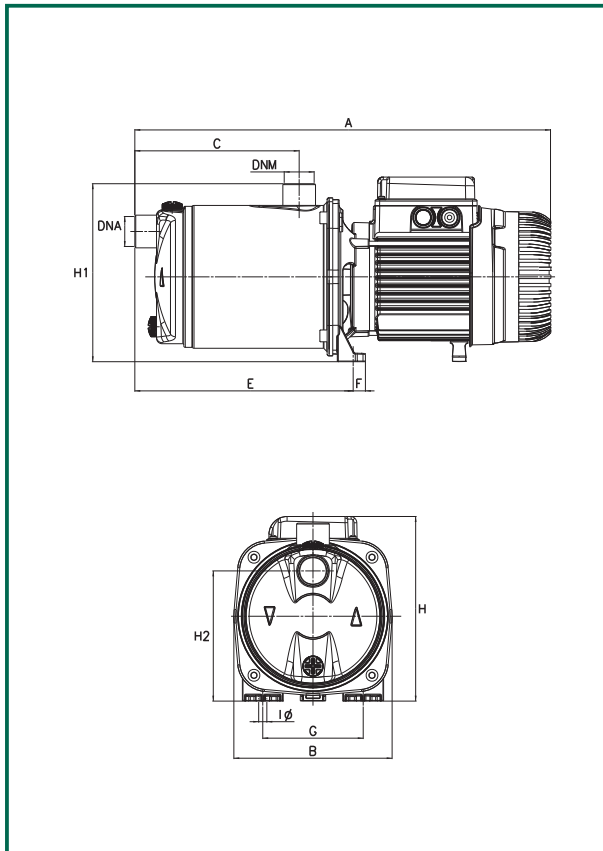

MODEL	A	B	C	E	F	G	I Ø	H	H1	H2	DNA	DNM	PACKING DIMENSIONS			VOLUME m ³	WEIGHT	
													L/A	L/B	H		M	T
EUROINOX 30/50 MT	384	174	108	186	13,5	111	9	193	196	143	1" G	1" G	440	206	245	0,025	10,7	10,5
EUROINOX 40/50 MT	458	174	166	241	13,5	111	9	203	196	143	1" G	1" G	480	212	265	0,031	14,8	14,6
EUROINOX 50/50 MT	458	174	166	241	13,5	111	9	203	196	143	1" G	1" G	480	212	265	0,031	15,5	15,1

MODEL	ELECTRICAL DATA								HYDRAULIC DATA (n ≈ 2800 1/min)											
	N° IMPELLER	VOLTAGE 50 Hz	P1 MAX kW	P2		In A	CAPACITOR		Q m ³ /h l/min	H (m)										
				NOMINAL kW	HP		µF	Vc		0	0,6	1,2	1,8	2,4	3	3,3	3,6	4,2	4,8	
EUROINOX 30/50 M	3	1x220-240 V ~	0,880	0,55	0,75	3,9	12,5	450	H (m)	42,2	40,2	38,2	36,2	33,8	30	27,5	24,8	19,5	14	
EUROINOX 30/50 T		3x230-400 V ~	0,870	0,55	0,75	2,8-1,6	-	-		57,7	55,3	52,8	50,1	47,1	42,7	39,5	35,8	28	19,2	
EUROINOX 40/50 M	4	1x220-240 V ~	1,200	0,75	1	5,3	25	450		72	68,5	65,5	62,1	58,2	52,2	48	43,6	34,5	26	
EUROINOX 40/50 T		3x230-400 V ~	1,180	0,75	1	3,8-2,2	-	-												
EUROINOX 50/50 M	5	1x220-240 V ~	1,480	1	1,36	6,3	25	450												
EUROINOX 50/50 T		3x230-400 V ~	1,440	1	1,36	4,4-2,5	-	-												

* Available on request.

The performance curves are based on the kinematic viscosity values = 1 mm²/s and density equal to 1000 Kg/m³. Curve tolerance according to ISO 9906.
 Liquid temperature range: from 0 °C to +35°C Maximum ambient temperature: +40°C

EUROINOX 80

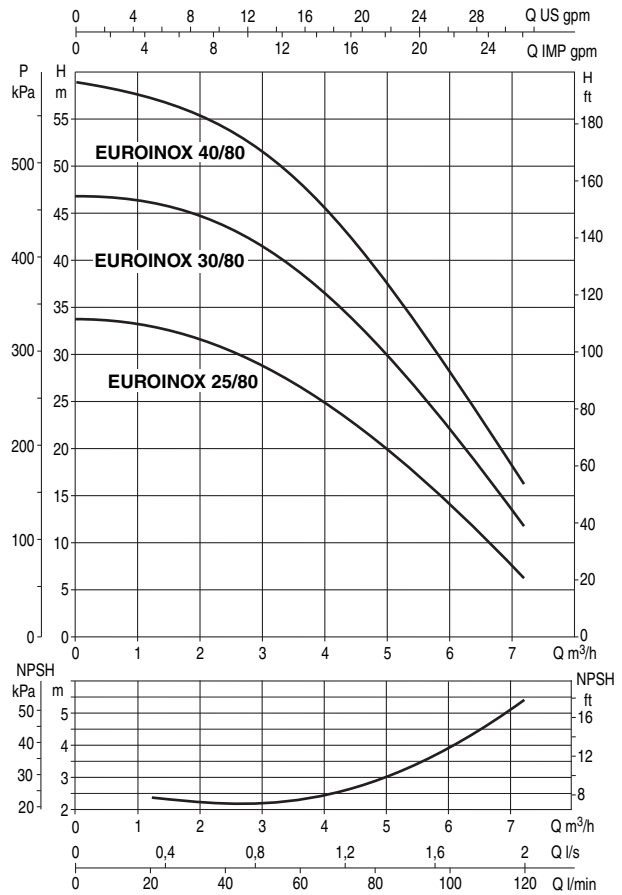
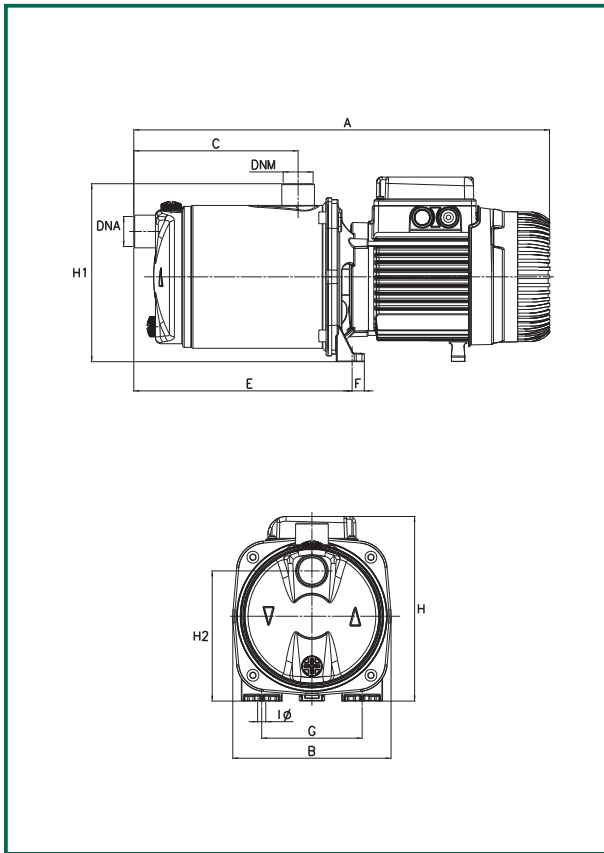

MODEL	A	B	C	E	F	G	I Ø	H	H1	H2	DNA	DNM	PACKING DIMENSIONS			VOLUME	WEIGHT	
													L/A	L/B	H	m ³	M	T
EUROINOX 25/80 MT	384	174	108	186	13,5	111	9	193	196	143	1" G	1" G	440	206	245	0,025	10,7	10,5
EUROINOX 30/80 MT	458	174	166	241	13,5	111	9	203	196	143	1" G	1" G	480	212	265	0,031	14,8	14,6
EUROINOX 40/80 MT	458	174	166	241	13,5	111	9	203	196	143	1" G	1" G	480	212	265	0,031	15,5	15,1

MODEL	ELECTRICAL DATA							HYDRAULIC DATA (n = 2800 1/min)																									
	N° IMPELLER	VOLTAGE 50 Hz	P1 MAX kW	P2 NOMINAL		In A	CAPACITOR		Q																								
				kW	HP		µF	Vc	m³/h	0	0,6	1,2	1,8	2,4	3	3,3	3,6	4,2	4,8	6	7,2												
EUROINOX 25/80 M	3	1x220-240 V ~	0,880	0,55	0,75	3,9	12,5	450	H (m)	34	33,7	33,2	32	30,5	28,7	27,5	26	23,9	21	14,5	6,3												
EUROINOX 25/80 T		3x230-400 V ~	0,870	0,55	0,75	2,8-1,6	-	-																									
EUROINOX 30/80 M	4	1x220-240 V ~	1,200	0,8	1,1	5,3	25	450														47,3	47	46,3	45,2	43,5	41	39,9	38	34,8	31	23	12
EUROINOX 30/80 T		3x230-400 V ~	1,180	0,8	1,1	3,8-2,2	-	-																									
EUROINOX 40/80 M	5	1x220-240 V ~	1,480	1	1,36	6,5	25	450														59	58	57	56	54	51	49,5	47,5	43,8	39,5	29,5	16
EUROINOX 40/80 T		3x230-400 V ~	1,440	1	1,36	4,4-2,5	-	-																									

EUROCOM



GENERAL DATA

Applications

Multistage horizontal centrifugal pump, featuring extremely silent running suitable for domestic use for water supply and pressurization, irrigation of gardens and vegetable gardens, and moving water in general.

Pump construction characteristics

Pump body in technopolymer. Motor support in die-cast aluminium, seal holder in AISI 304 steel. Mechanical seal in carbon/ceramic. Rotor shaft in AISI 304 steel. Impellers, diffuser bodies and diffusers in technopolymer. Wear rings in stainless steel.

Motor construction characteristics

Continuous duty asynchronous motor.

Built-in thermal and current overload protection and a capacitor permanently in circuit in the single-phase version.

Protection for the three-phase version is the responsibility of the user.

Motor protection level: IP 44

Terminal board protection level: IP 55

Insulation class: F

Standard voltage: single-phase 220/240V - 50 Hz - 2 poles
 three-phase 230/400V - 50 Hz - 2 poles

TECHNICAL DATA

N.	PARTS	MATERIALS
1	PUMP BODY	TECHNOPOLYMER
4	IMPELLER	TECHNOPOLYMER
6	DIFFUSER	TECHNOPOLYMER
7	SHAFT WITH ROTOR	AISI 304 X5CRNI 1810 UNI 6900/71 STAINLESS STEEL
16	MECHANICAL SEAL	CARBON/CERAMIC
28	GASKET OR	NBR
36	SEAL HOLDER COVER	AISI 304 X5CRNI 1810 UNI 6900/71 STAINLESS STEEL
98	DIFFUSER BODY	TECHNOPOLYMER
304	REAR DISK	TECHNOPOLYMER

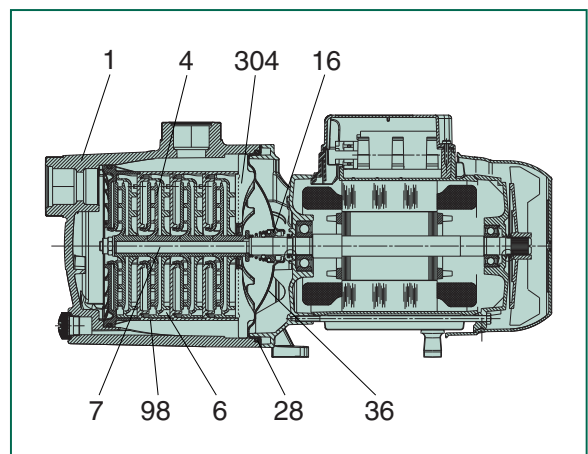

- Operating range: from 10 to 120 l/min. with a head of up to 72 m.
- Pumped liquid characteristics: clean, free from solid or abrasive substances, not viscous, not aggressive, not crystallised, chemically neutral and close to the characteristics of water.
- Liquid temperature range: from 0°C to +35°C for domestic use (EN 60335-2-41)
from 0°C to +40°C for other uses.
- Maximum ambient temperature: +40°C
- Maximum operating pressure: 6 bar (600 kPa)
- Installation: fixed or portable in a horizontal position

The performance curves are based on the kinematic viscosity values = 1 mm²/s and density equal to 1000 Kg/m³. Curve tolerance according to ISO 9906.
 Liquid temperature range: from 0 °C to +35°C
 Maximum ambient temperature: +40°C

EUROCOM 30

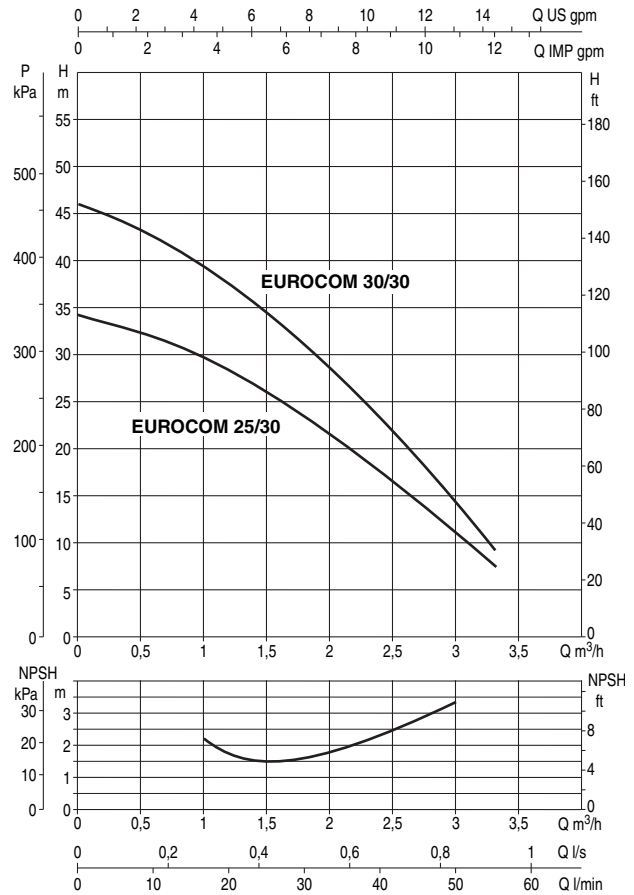
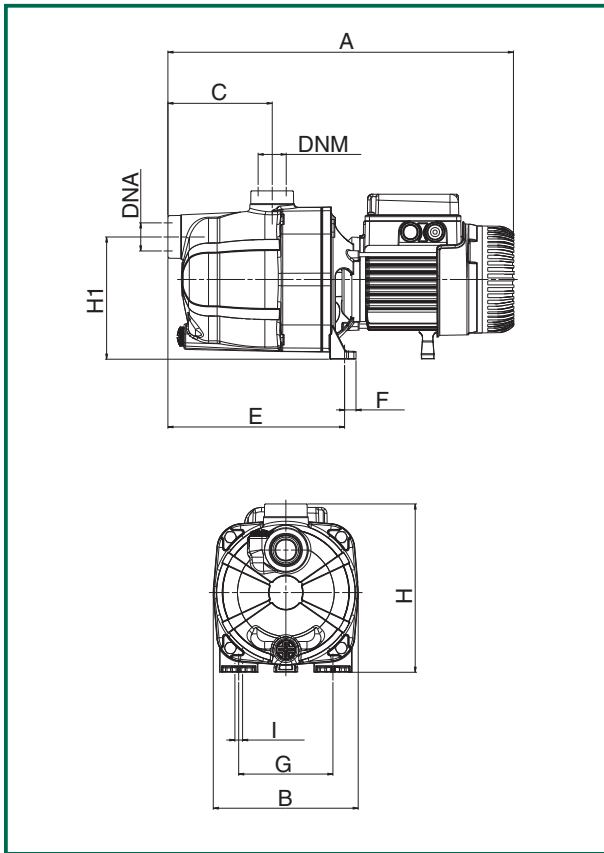

MODEL	A	B	C	E	F	G	I Ø	H	H1	H2	DNA	DNM	PACKING DIMENSIONS			VOLUME m ³	WEIGHT	
													L/A	L/B	H		M	T
EUROCOM 25/30	406	170	122	208	14	111	9	198	144	-	1" G	1" G	470	240	240	0,027	8	8
EUROCOM 30/30	406	170	122	208	14	111	9	198	144	-	1" G	1" G	470	240	240	0,027	8,8	8,8

MODEL	ELECTRICAL DATA							HYDRAULIC DATA (n = 2800 1/min)														
	N° IMPELLER	VOLTAGE 50 Hz	P1 MAX kW	P2		In A	CAPACITOR µF Vc	Q														
				NOMINAL kW	HP			0	0,6	1,2	1,8	2,4	3	3,3								
EUROCOM 25/30 M	3	1x220-240 V ~	0,52	0,37	0,5	2,4	10	H (m)	34	31,7	28,3	23,5	17,5	11	8							
EUROCOM 25/30 T		3x230-400 V ~	0,56	0,37	0,5	1,9/1,1	-									-						
EUROCOM 30/30 M	4	1x220-240 V ~	0,72	0,44	0,6	3,4	12,5									46	42,2	37,8	31,2	23,3	14,3	10
EUROCOM 30/30 T		3x230-400 V ~	0,7	0,44	0,6	2,7/1,5	-									-						

The performance curves are based on the kinematic viscosity values = 1 mm²/s and density equal to 1000 Kg/m³. Curve tolerance according to ISO 9906.
 Liquid temperature range: from 0 °C to +35°C
 Maximum ambient temperature: +40°C

EUROCOM 50

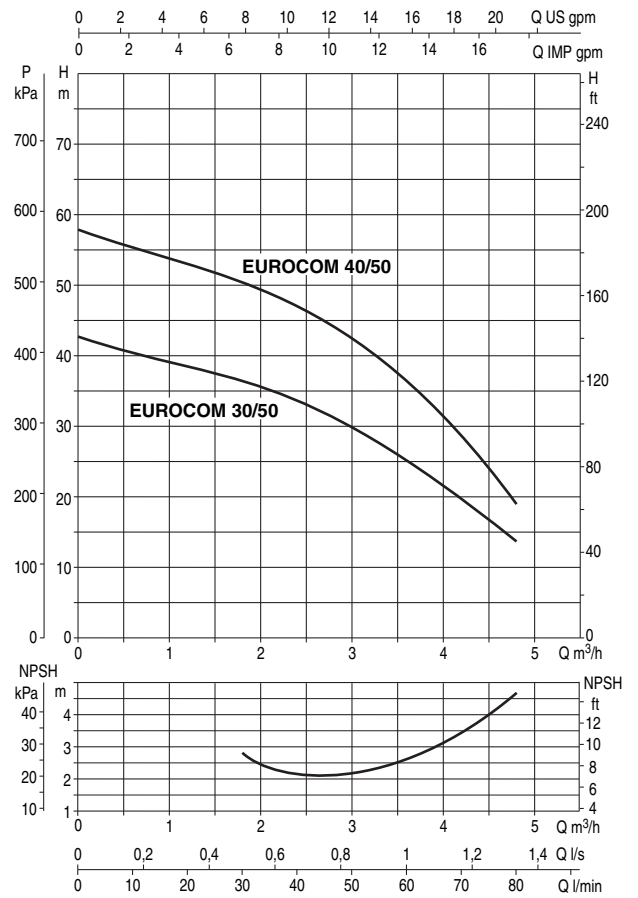
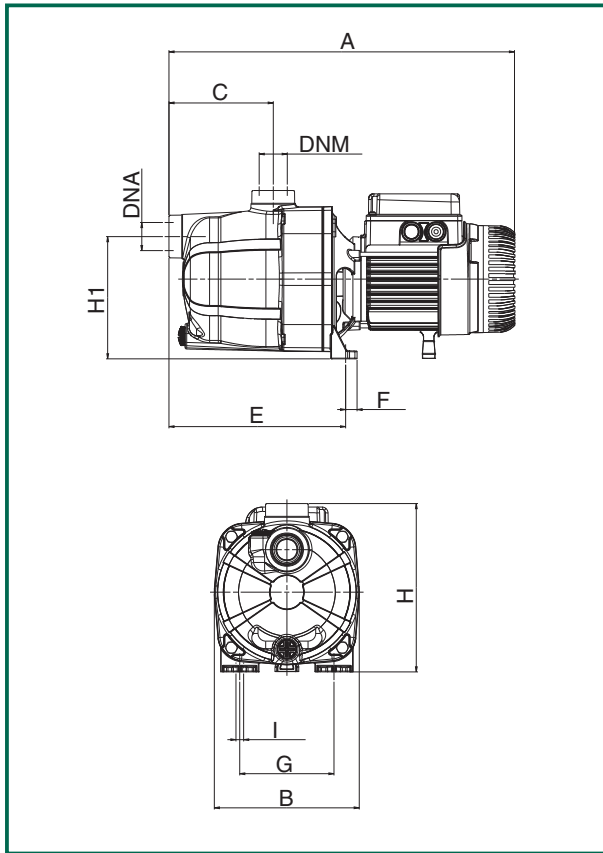

MODEL	A	B	C	E	F	G	I Ø	H	H1	H2	DNA	DNM	PACKING DIMENSIONS			VOLUME m ³	WEIGHT	
													L/A	L/B	H		M	T
EUROCOM 30/50	406	170	122	208	14	111	9	198	144	-	1" G	1" G	470	240	240	0,027	8,8	8,8
EUROCOM 40/50	406	170	122	208	14	111	9	203	144	-	1" G	1" G	470	240	240	0,027	11	11,3

MODEL	ELECTRICAL DATA								HYDRAULIC DATA (n ≈ 2800 1/min)											
	N° IMPELLER	VOLTAGE 50 Hz	P1 MAX kW	P2 NOMINAL		In A	CAPACITOR		Q m³/h l/min	H (m)										
				kW	HP		µF	Vc		0	0,6	1,2	1,8	2,4	3	3,3	3,6	4,2	4,8	
EUROCOM 30/50 M	3	1x220-240 V ~	0,88	0,55	0,75	3,9	12,5	450	H (m)	42	40,2	38,2	36,2	33,8	30	27,5	24,8	19,5	14	
EUROCOM 30/50 T		3x230-400 V ~	0,87	0,55	0,75	2,8/1,6	-	-		58	55,3	52,8	50,1	47,1	42,7	39,5	35,8	28	19	
EUROCOM 40/50 M	4	1x220-240 V ~	1,2	0,75	1	5,3	20	450		42	40,2	38,2	36,2	33,8	30	27,5	24,8	19,5	14	
EUROCOM 40/50 T		3x230-400 V ~	1,18	0,75	1	3,8/2,2	-	-		58	55,3	52,8	50,1	47,1	42,7	39,5	35,8	28	19	

The performance curves are based on the kinematic viscosity values = 1 mm²/s and density equal to 1000 Kg/m³. Curve tolerance according to ISO 9906.
 Liquid temperature range: from 0 °C to +35°C Maximum ambient temperature: +40°C

EUROCOM 80

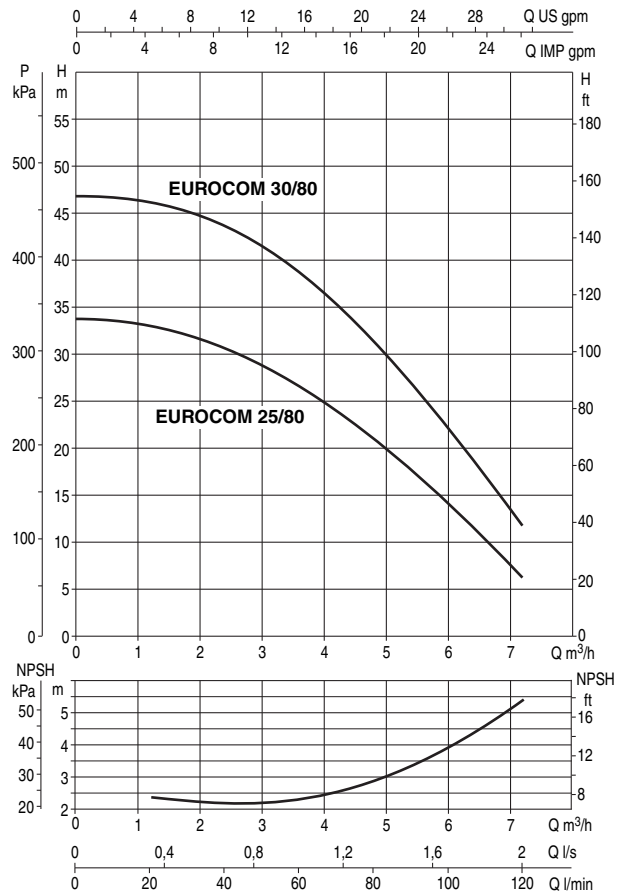
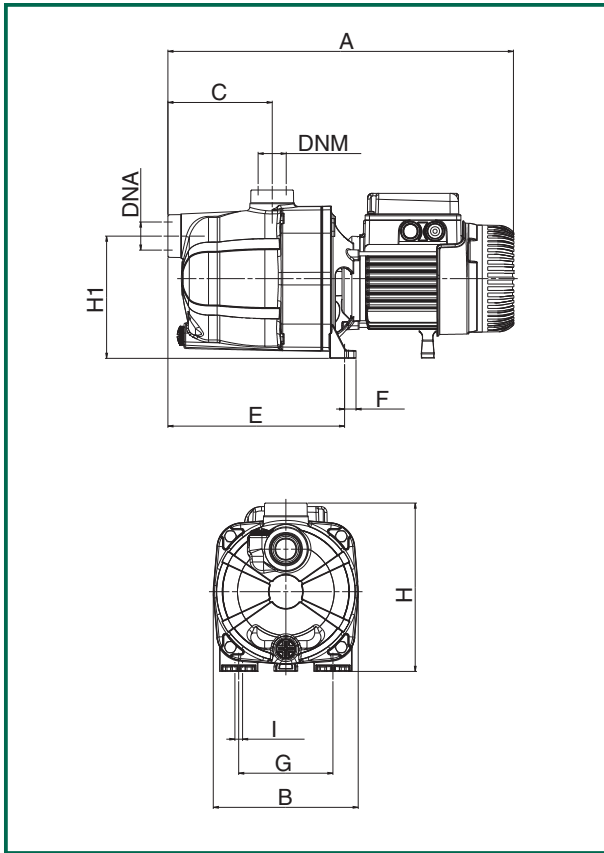

MODEL	A	B	C	E	F	G	I Ø	H	H1	H2	DNA	DNM	PACKING DIMENSIONS			VOLUME m ³	WEIGHT	
													L/A	L/B	H		M	T
EUROCOM 25/80	406	170	122	208	14	111	9	198	144	-	1" G	1" G	470	240	240	0,027	8,8	8,8
EUROCOM 30/80	406	170	122	208	14	111	9	203	144	-	1" G	1" G	470	240	240	0,027	11	11,3

MODEL	ELECTRICAL DATA							HYDRAULIC DATA (n = 2800 1/min)														
	N° IMPELLER	VOLTAGE 50 Hz	P1 MAX kW	P2		In A	CAPACITOR		Q													
				NOMINAL kW	HP		µF	Vc	m ³ /h	0	0,6	1,2	1,8	2,4	3	3,3	3,6	4,2	4,8	6	7,2	
EUROCOM 25/80 M	3	1x220-240 V ~	0,88	0,55	0,75	3,9	12,5	450	H (m)	34	33,7	33,2	32	30,5	28,7	27,5	26	23,9	21	14,5	6,3	
EUROCOM 25/80 T		3x230-400 V ~	0,87	0,55	0,75	2,8/1,6	-	-		47,3	47	46,3	45,2	43,5	41	39,9	38	34,8	31	23	12	
EUROCOM 30/80 M	4	1x220-240 V ~	1,14	0,8	1,1	5,2	20	450		47,3	47	46,3	45,2	43,5	41	39,9	38	34,8	31	23	12	
EUROCOM 30/80 T		3x230-400 V ~	1,04	0,8	1,1	3,3/1,9	-	-		47,3	47	46,3	45,2	43,5	41	39,9	38	34,8	31	23	12	

JET - JETINOX - EURO - EUROINOX

FITTED ELECTROPUMPS



JET M-P



JET 200 M-P e T-P JET 300 M-P e T-P



JET 151-251 M-P

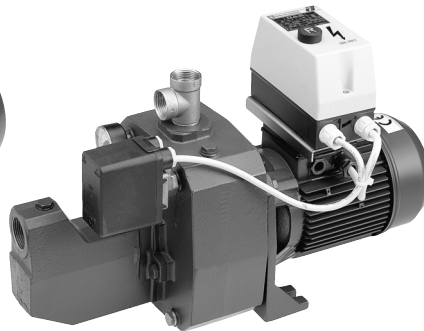

JET 151-251 T-P



JETINOX M-P

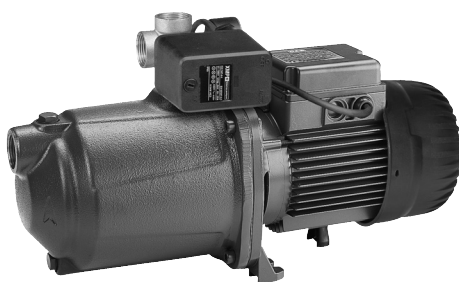

EURO M-P

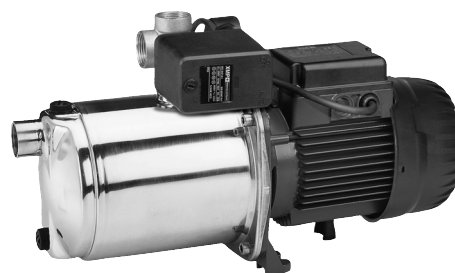

EUROINOX M-P



SINGLE-PHASE VERSION: self-priming electropump equipped with pressure gauge, pressure switch, power supply cable with plug and three-way brass connector for connecting to a tank.

THREE-PHASE VERSION: self-priming electropump equipped with pressure gauge, pressure switch, overload cutout and three-way brass connector for connecting to a tank.

JET

Liquid temperature range: from 0 °C to +35°C

Maximum ambient temperature: +40°C

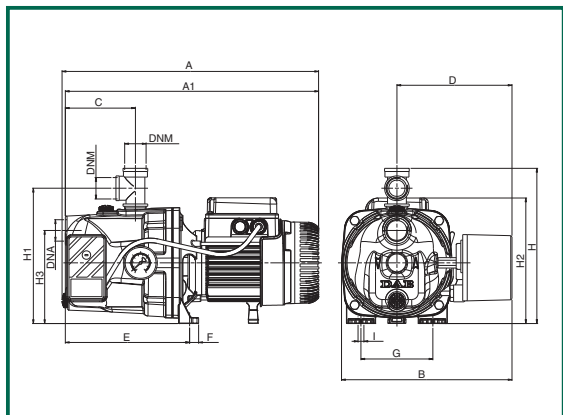

MODEL	VOLTAGE 50 Hz	MOTOR		
		HP	KW	A
JET 62 MP	1x220-240 V ~	0,6	0,44	3,12
JET 82 MP	1x220-240 V ~	0,8	0,6	3,8
JET 102 MP	1x220-240 V ~	1	0,75	5,1
JET 112 MP	1x220-240 V ~	1,36	1	6,2
JET 92 MP	1x220-240 V ~	1	0,75	4,2
JET 132 MP	1x220-240 V ~	1,36	1	6,6
JET 200 MP	1x220-240 V ~	2	1,5	9
JET 200 TP	3x400 V ~	2	1,5	3,9
JET 300 MP	1x220-240 V ~	3	2,2	12
JET 300 TP	3x400 V ~	3	2,2	4,9
JET 151 MP	1x220-240 V ~	1,5	1,1	7,2
JET 151 TP	3x400 V ~	1,5	1,1	3
JET 251 MP	1x220-240 V ~	2,5	1,85	10
JET 251 TP	3x400 V ~	2,5	1,85	4

MODEL	A	A1	B	C	D	E	F	G	I Ø	H	H1	H2	H3	I	DNA	DNM	PACKING DIMENSIONS			VOLUME m ³	WEIGHT Kg
																	L/A	L/B	H		
JET 62 MP	395	390	263	108	177	192	14	111	-	239	209	193	144	9	1" G	1" G	440	295	235	0,031	11,9
JET 82 MP	395	390	263	108	177	192	14	111	-	239	209	193	144	9	1" G	1" G	440	295	235	0,031	12,1
JET 102 MP	414	390	263	108	177	192	14	111	-	239	209	203	144	9	1" G	1" G	440	295	235	0,031	13,9
JET 112 MP	414	390	263	108	177	192	14	111	-	239	209	203	144	9	1" G	1" G	440	295	235	0,031	14,9
JET 92 MP	395	390	263	108	177	192	14	111	-	239	209	193	144	9	1" G	1" G	440	295	235	0,031	13,1
JET 132 MP	414	390	263	108	177	192	14	111	-	239	209	203	144	9	1" G	1" G	440	295	235	0,031	14,9
JET 200 MP	521	-	294	151	-	282	20	160	11	275	175	-	-	-	1 1/2" G	1 1/4" G	600	236	267	0,038	27,5
JET 200 TP	521	-	294	151	-	282	20	160	11	275	175	-	-	-	1 1/2" G	1 1/4" G	600	236	267	0,038	26
JET 300 MP	595	-	294	151	-	282	20	160	11	275	175	-	-	-	1 1/2" G	1 1/4" G	660	236	267	0,042	31,5
JET 300 TP	521	-	294	151	-	282	20	160	11	275	175	-	-	-	1 1/2" G	1 1/4" G	600	236	267	0,038	28
JET 151 MP	558	-	290	220	-	367	15	145	11	305	165	-	-	-	1 1/4" G	1" G	600	236	267	0,038	31,5
JET 151 TP	558	-	290	220	-	367	15	145	11	305	165	-	-	-	1 1/4" G	1" G	600	236	267	0,038	31,5
JET 251 MP	632	-	290	220	-	367	15	145	11	305	165	-	-	-	1 1/4" G	1" G	645	236	267	0,040	36
JET 251 TP	558	-	290	220	-	367	15	145	11	305	165	-	-	-	1 1/4" G	1" G	600	236	267	0,038	32

JETINOX

Liquid temperature range: from 0 °C to +35°C

Maximum ambient temperature: +50°C

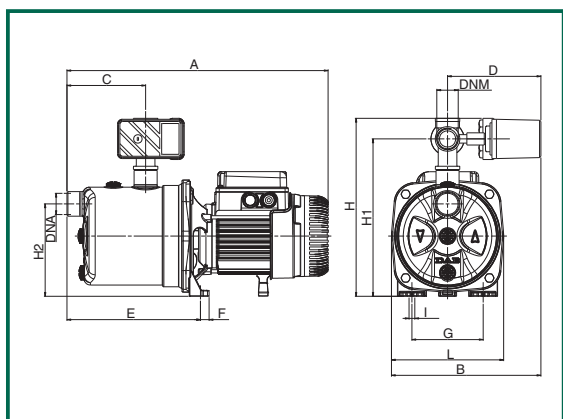

MODEL	VOLTAGE 50 Hz	MOTOR		
		HP	KW	A
JETINOX 82 MP	1x220-240 V ~	0,8	0,6	3,8
JETINOX 102 MP	1x220-240 V ~	1	0,75	5,1
JETINOX 112 MP	1x220-240 V ~	1,36	1	6,2
JETINOX 92 MP	1x220-240 V ~	1	0,75	4,2
JETINOX 132 MP	1x220-240 V ~	1,36	1	6,6

MODEL	A	B	C	D	E	F	G	H	H1	H2	I	L	DNA	DNM	PACKING DIMENSIONS			VOL. m ³	WEIGHT Kg
															L/A	L/B	H		
JETINOX 82 MP	406	232	122	145	207	14	111	276	244	144	9	174	1" G	1" G	450	276	320	0,031	9,2
JETINOX 102 MP	424	232	122	145	207	14	111	276	244	144	9	174	1" G	1" G	450	276	320	0,031	11,0
JETINOX 112 MP	424	232	122	145	207	14	111	276	244	144	9	174	1" G	1" G	450	276	320	0,031	12,0
JETINOX 92 MP	406	232	122	145	207	14	111	276	244	144	9	174	1" G	1" G	450	276	320	0,031	10,2
JETINOX 132 MP	424	232	122	145	207	14	111	276	244	144	9	174	1" G	1" G	450	276	320	0,031	12,0

EURO

Liquid temperature range: from 0 °C to +35°C Maximum ambient temperature: +40°C

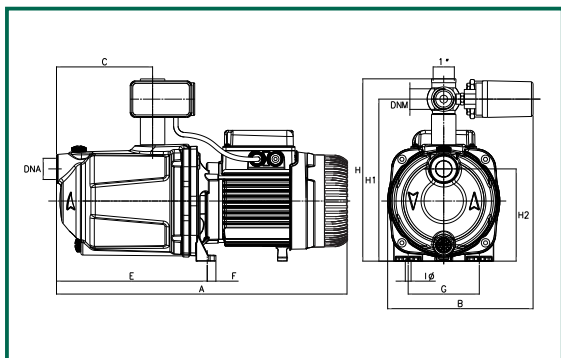

MODEL	VOLTAGE 50 Hz	MOTOR		
		HP	kW	A
EURO 25/30 MP	1x220-240 V ~	0,5	0,37	2,4
EURO 30/30 MP	1x220-240 V ~	0,6	0,45	3,2
EURO 40/30 MP	1x220-240 V ~	0,75	0,55	3,9
EURO 30/50 MP	1x220-240 V ~	0,75	0,55	3,9
EURO 40/50 MP	1x220-240 V ~	1	0,75	5,3
EURO 50/50 MP	1x220-240 V ~	1,36	1	6,3
EURO 25/80 MP	1x220-240 V ~	0,75	0,55	3,9
EURO 30/80 MP	1x220-240 V ~	1	0,75	5,3
EURO 40/80 MP	1x220-240 V ~	1,36	1	6,5

MODEL	A	B	C	E	F	G	I Ø	H	H1	H2	DNA	DNM	WEIGHT Kg
EURO 25/30 MP	378	226	94,5	180	13,5	111	9	281	250	143,5	1" G	1" G	13,3
EURO 30/30 MP	433	226	149,5	235	13,5	111	9	281	250	143,5	1" G	1" G	14,3
EURO 40/30 MP	433	226	149,5	235	13,5	111	9	281	250	143,5	1" G	1" G	14,8
EURO 30/50 MP	378	226	94,5	180	13,5	111	9	281	250	143,5	1" G	1" G	13,8
EURO 40/50 MP	452	226	149,5	235	13,5	111	9	281	250	143,5	1" G	1" G	15,3
EURO 50/50 MP	452	226	149,5	235	13,5	111	9	281	250	143,5	1" G	1" G	16,8
EURO 25/80 MP	378	226	94,5	180	13,5	111	9	281	250	143,5	1" G	1" G	13,8
EURO 30/80 MP	452	226	149,5	235	13,5	111	9	281	250	143,5	1" G	1" G	15,3
EURO 40/80 MP	452	226	149,5	235	13,5	111	9	281	250	143,5	1" G	1" G	16,8

EUROINOX

Liquid temperature range: from 0 °C to +35°C Maximum ambient temp: +40°C

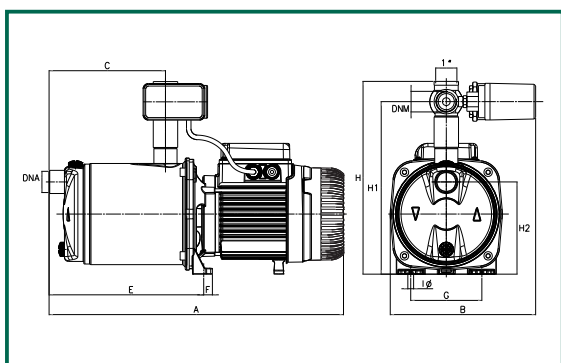

MODEL	VOLTAGE 50 Hz	MOTOR		
		HP	kW	A
EUROINOX 25/30 MP	1x220-240 V ~	0,5	0,37	2,4
EUROINOX 30/30 MP	1x220-240 V ~	0,6	0,45	3,2
EUROINOX 40/30 MP	1x220-240 V ~	0,75	0,55	3,9
EUROINOX 30/50 MP	1x220-240 V ~	0,75	0,55	3,9
EUROINOX 40/50 MP	1x220-240 V ~	1	0,75	5,3
EUROINOX 50/50 MP	1x220-240 V ~	1,36	1	6,3
EUROINOX 25/80 MP	1x220-240 V ~	0,75	0,55	3,9
EUROINOX 30/80 MP	1x220-240 V ~	1	0,75	5,3
EUROINOX 40/80 MP	1x220-240 V ~	1,36	1	6,5

MODEL	A	B	C	E	F	G	I Ø	H	H1	H2	DNA	DNM	WEIGHT Kg
EUROINOX 25/30 MP	384	226	108	186	13,5	111	9	300	268	143	1" G	1" G	10,9
EUROINOX 30/30 MP	439	226	166	241	13,5	111	9	300	268	143	1" G	1" G	12,9
EUROINOX 40/30 MP	439	226	166	241	13,5	111	9	300	268	143	1" G	1" G	13
EUROINOX 30/50 MP	384	226	108	186	13,5	111	9	300	268	143	1" G	1" G	11,7
EUROINOX 40/50 MP	458	226	166	241	13,5	111	9	300	268	143	1" G	1" G	15,8
EUROINOX 50/50 MP	458	226	166	241	13,5	111	9	300	268	143	1" G	1" G	16,5
EUROINOX 25/80 MP	384	226	108	186	13,5	111	9	300	268	143	1" G	1" G	11,7
EUROINOX 30/80 MP	458	226	166	241	13,5	111	9	300	268	143	1" G	1" G	15,8
EUROINOX 40/80 MP	458	226	166	241	13,5	111	9	300	268	143	1" G	1" G	16,5

ACTIVE J - ACTIVE JI - ACTIVE JC ACTIVE E - ACTIVE EI - ACTIVE EC

ACTIVE SYSTEM



ACTIVE J



ACTIVE JI



ACTIVE JC



ACTIVE EI



GENERAL DATA

Applications

Automatic water lifting units, particularly suitable for domestic use, small installations for civil, agricultural, industrial use, washing and hobby applications.

The units are characterised by the use of:

- JET, JETINOX, JETCOM EUROINOX self-priming electropumps that can operate even when there are air bubbles and gas. They are indispensable for use in artesian wells and where suction difficulties arise.

The EURO - EUROCOM multistage centrifugal pumps are particularly appropriate for low-noise underwater operation and can increase plant pressure when this is not sufficient or not regular.

Characteristics

The ACTIVE system is a built-in, easy-to-install, and ready-to-use device which:

- controls it
- commands it automatically
- regulates its functioning
- limits starts
- guarantees pressure stability inside the hydraulic circuit
- electronically controls starting pressure.

Operation

Equipped with a dual control device, the ACTIVE system collects and processes, by means of an electronic circuit, all data related to the water pressure and flow. The electric pump always works at the utmost conditions. On the opening of a cycle, with a minimum water extraction, the electric pump is started by the Active system after the pressure of the system has dropped to the set level that can be adjusted from 1.5 to 2.5 bar by the user. Active limits the number of start-ups of the electric pump in the event of leaks in the system, small drops and seeping or small extractions. The Active system eliminates the water hammer because, with the interruption of the water extraction, the electric pump stops at zero flow rate.

In the event of lack of suction water, the Active system intervenes preventing the electric pump from dry working. On returned normal functioning conditions, ACTIVE automatically restores operation.

Maintenance and adjustment are not necessary.

The performance curves are based on the kinematic viscosity values = 1 mm²/s and density equal to 1000 Kg/m³. Curve tolerance according to ISO 9906.

ACTIVE J

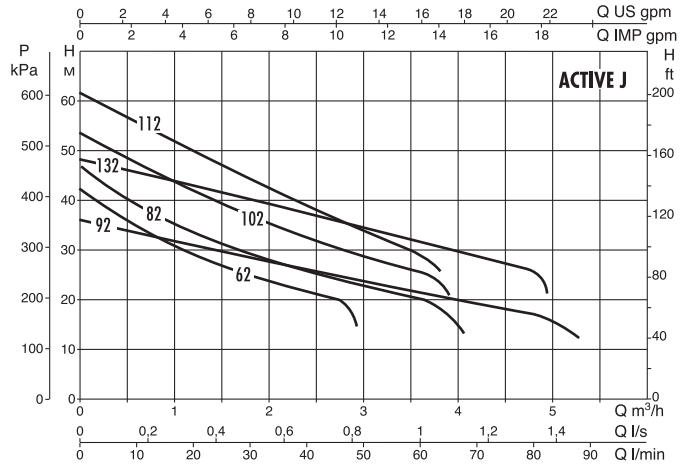
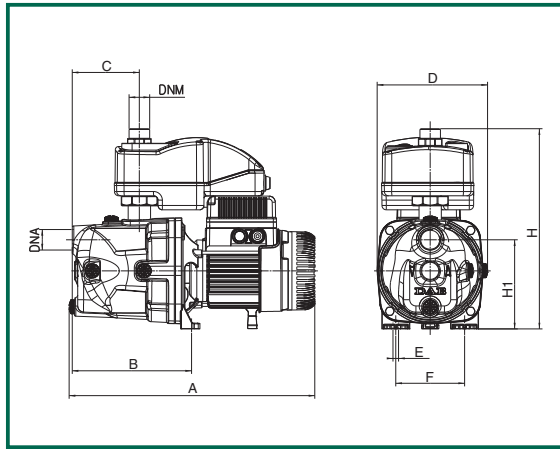

MODEL	A	B	C	D	E	F	H	H1	DNA	DNM	PACKING DIMENSIONS			WEIGHT Kg
											A	B	C	
ACTIVE J 62 M	395	192	108	178	9	111	322	144	1" G	1" G	476	234	348	10,50
ACTIVE J 82 M	395	192	108	178	9	111	322	144	1" G	1" G	476	234	348	13,2
ACTIVE J 102 M	395	192	108	178	9	111	322	144	1" G	1" G	476	234	348	12,50
ACTIVE J 112 M	395	192	108	178	9	111	322	144	1" G	1" G	476	234	348	13,50
ACTIVE J 92 M	395	192	108	178	9	111	322	144	1" G	1" G	476	234	348	11,70
ACTIVE J 132 M	395	192	108	178	9	111	322	144	1" G	1" G	476	234	348	13,50

MODEL	ELECTRICAL DATA						HYDRAULIC DATA (n ~ 2800 1/min)												
	VOLTAGE 50 Hz	P1 MAX kW	P2 NOMINAL		In A	CAPACITOR		Q											
			kW	HP		μF	Vc	m ³ /h	0	0,6	1,2	1,8	2,4	3,0	3,6	4,2	4,8		
ACTIVE J 62 M	1x220-240 V ~	0,720	0,44	0,6	3,12	12,5	450	H (m)	42	35	29,2	25,6	21,1						
ACTIVE J 82 M	1x220-240 V ~	0,850	0,6	0,8	3,8	12,5	450		47	40	34	30	26,2	23,5	20,3				
ACTIVE J 102 M	1x220-240 V ~	1,130	0,75	1	5,1	16	450		53,8	47	41	36,3	32,4	28,8	25,8				
ACTIVE J 112 M	1x220-240 V ~	1,400	1	1,36	6,2	25	450		61	54	47,8	42,8	38,8	34,8	22				
ACTIVE J 92 M	1x220-240 V ~	0,940	0,75	1	4,2	14	450		36,2	33,5	31	28,4	26	24	21,8	19,6	17		
ACTIVE J 132 M	1x220-240 V ~	1,490	1	1,36	6,6	25	450		48	45,6	42,8	40	37,6	35	32,5	30	27		

The performance curves are based on the kinematic viscosity values = 1 mm²/s and density equal to 1000 Kg/m³. Curve tolerance according to ISO 9906.

ACTIVE JI

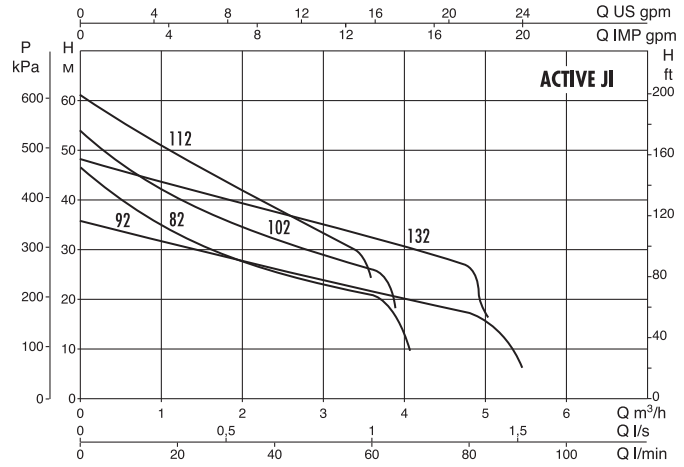
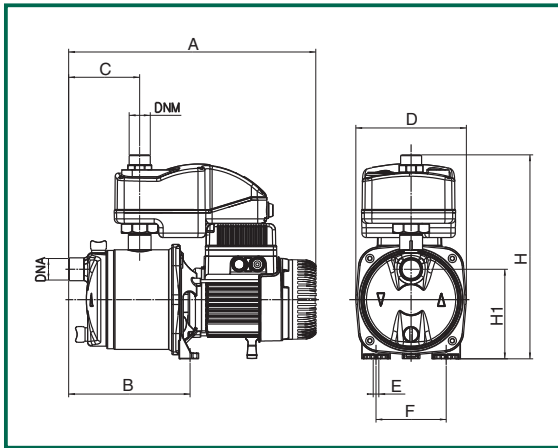

MODEL	A	B	C	D	E	F	H	H1	DNA	DNM	PACKING DIMENSIONS			WEIGHT Kg
											A	B	C	
ACTIVE JI 82 M	390	192	112	174	9	111	322	141	1" G	1" G	476	234	348	10,70
ACTIVE JI 102 M	390	192	112	174	9	111	322	141	1" G	1" G	476	234	348	12,50
ACTIVE JI 112 M	390	192	112	174	9	111	322	141	1" G	1" G	476	234	348	13,50
ACTIVE JI 92 M	390	192	112	174	9	111	322	141	1" G	1" G	476	234	348	11,70
ACTIVE JI 132 M	390	192	112	174	9	111	322	141	1" G	1" G	476	234	348	13,50

MODEL	ELECTRICAL DATA						HYDRAULIC DATA (n = 2800 1/min)													
	VOLTAGE 50 Hz	P1 MAX kW	P2 NOMINAL		In A	CAPACITOR		Q												
			kW	HP		μF	Vc	m³/h	0	0,6	1,2	1,8	2,4	3,0	3,6	4,2	4,8			
ACTIVE JI 82 M	1x220-240 V ~	0,850	0,6	0,8	3,8	12,5	450	H (m)	47	40	34	30	26,2	23,5	20,3					
ACTIVE JI 102 M	1x220-240 V ~	1,130	0,75	1	5,1	16	450		53,8	47	41	36,3	32,4	28,8	25,8					
ACTIVE JI 112 M	1x220-240 V ~	1,400	1	1,36	6,2	25	450		61	54	47,8	42,8	38,8	34,8	22					
ACTIVE JI 92 M	1x220-240 V ~	0,940	0,75	1	4,2	14	450		36,2	33,5	31	28,4	26	24	21,8	19,6	17			
ACTIVE JI 132 M	1x220-240 V ~	1,490	1	1,36	6,6	25	450		48,3	45,6	42,8	40	37,6	35	32,5	30	27,2			

The performance curves are based on the kinematic viscosity values = 1 mm²/s and density equal to 1000 Kg/m³. Curve tolerance according to ISO 9906.

ACTIVE JC

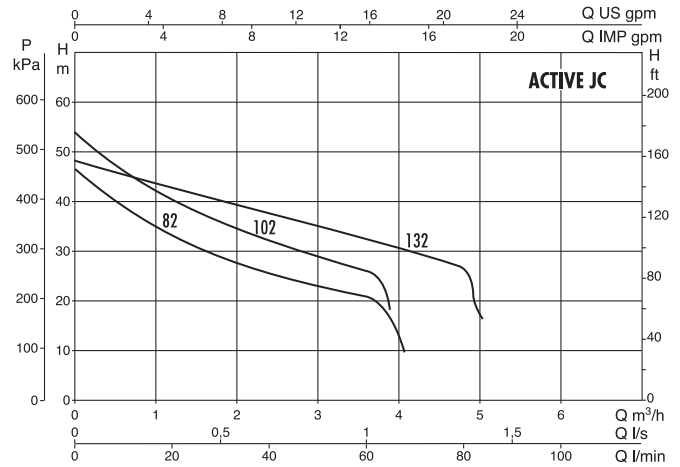
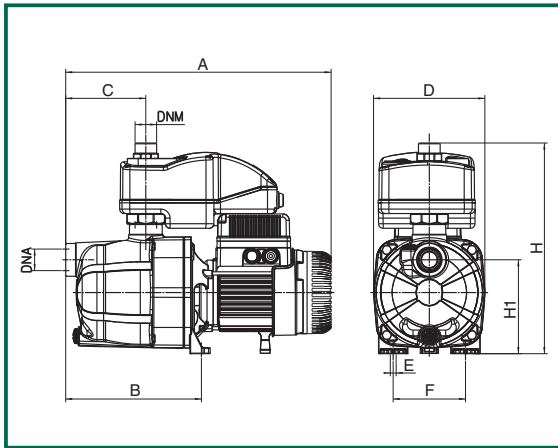

MODEL	A	B	C	D	E	F	H	H1	DNA	DNM	PACKING DIMENSIONS			WEIGHT Kg
											A	B	C	
ACTIVE JC 82 M	406	208	122	170	9	111	322	144	1" G	1" G	476	234	348	10,70
ACTIVE JC 102 M	406	208	122	170	9	111	322	144	1" G	1" G	476	234	348	12,50
ACTIVE JC 132 M	406	208	122	170	9	111	322	144	1" G	1" G	476	234	348	13,50

MODEL	ELECTRICAL DATA						HYDRAULIC DATA (n ≈ 2800 1/min)										
	VOLTAGE 50 Hz	P1 MAX kW	P2 NOMINAL		In A	CAPACITOR		Q									
			kW	HP		μF	Vc	m ³ /h	0	0,6	1,2	1,8	2,4	3,0	3,6	4,2	4,8
ACTIVE JC 82 M	1x220-240 V ~	0,850	0,6	0,8	3,8	12,5	450	H (m)	47	40	34	30	26,2	23,5	20,3		
ACTIVE JC 102 M	1x220-240 V ~	1,130	0,75	1	5,1	16	450		53,8	47	41	36,3	32,4	28,8	25,8		
ACTIVE JC 132 M	1x220-240 V ~	1,490	1	1,36	6,6	25	450		48	45,6	42,8	40	37,6	35	32,5	30	27

The performance curves are based on the kinematic viscosity values = 1 mm²/s and density equal to 1000 Kg/m³. Curve tolerance according to ISO 9906.

ACTIVE E

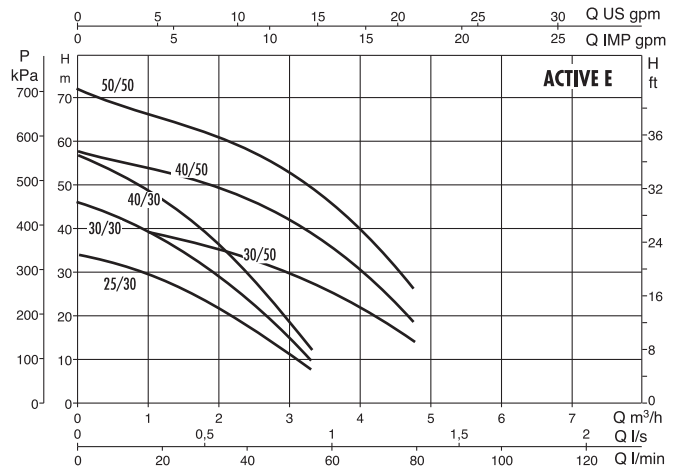
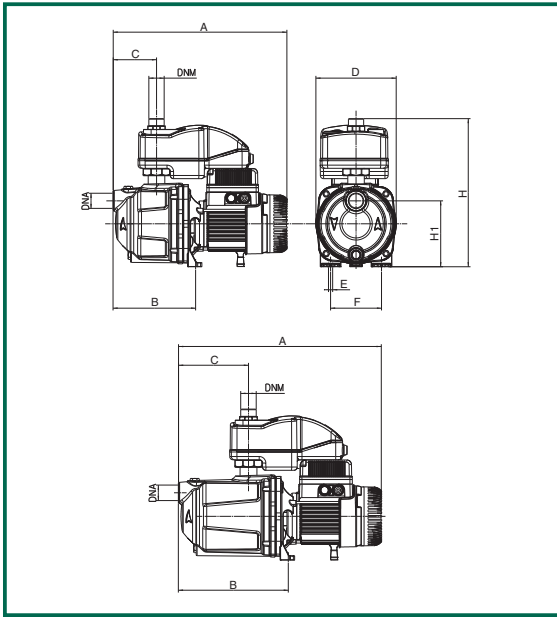

MODEL	A	B	C	D	E	F	H	H1	DNA	DNM	PACKING DIMENSIONS			WEIGHT Kg
											A	B	C	
ACTIVE E 25/30 M	377	180	94	175	9	111	322	144	1" G	1" G	476	234	348	10,90
ACTIVE E 30/30 M	432	235	149	175	9	111	322	144	1" G	1" G	476	234	348	12,90
ACTIVE E 40/30 M	432	235	149	175	9	111	322	144	1" G	1" G	476	234	348	13,00
ACTIVE E 30/50 M	377	180	94	175	9	111	322	144	1" G	1" G	476	234	348	11,70
ACTIVE E 40/50 M	432	235	149	175	9	111	322	144	1" G	1" G	476	234	348	15,60
ACTIVE E 50/50 M	432	235	149	175	9	111	322	144	1" G	1" G	476	234	348	16,20

MODEL	ELECTRICAL DATA						HYDRAULIC DATA (n = 2800 1/min)																	
	VOLTAGE 50 Hz	P1 MAX kW	P2 NOMINAL		In A	CAPACITOR μF	Vc	Q																
			kW	HP				0	0,6	1,2	1,8	2,4	3,0	3,6	4,2	4,8	6	7,2						
ACTIVE E 25/30 M	1x220-240 V ~	0,520	0,37	0,5	2,4	10	450	34,4	31,7	28,3	23,5	17,5	11											
ACTIVE E 30/30 M	1x220-240 V ~	0,720	0,45	0,6	3,2	12,5	450	46	42,2	37,8	31,2	23,3	14,3											
ACTIVE E 40/30 M	1x220-240 V ~	0,880	0,55	0,75	3,9	12,5	450	57	52,7	47	38,8	29	17,7											
ACTIVE E 30/50 M	1x220-240 V ~	0,880	0,55	0,75	3,9	12,5	450	42,2	40,2	38,2	36,2	33,8	30	24,8	19,5	14								
ACTIVE E 40/50 M	1x220-240 V ~	1,200	0,8	1,1	5,3	20	450	57	55,3	52,8	50,1	47,1	42,7	35,8	28	19								
ACTIVE E 50/50 M	1x220-240 V ~	1,480	1	1,36	6,3	25	450	72	68,5	65,5	62,1	58,2	52,2	43,6	34,5	26								

The performance curves are based on the kinematic viscosity values = 1 mm²/s and density equal to 1000 Kg/m³. Curve tolerance according to ISO 9906.

ACTIVE EI

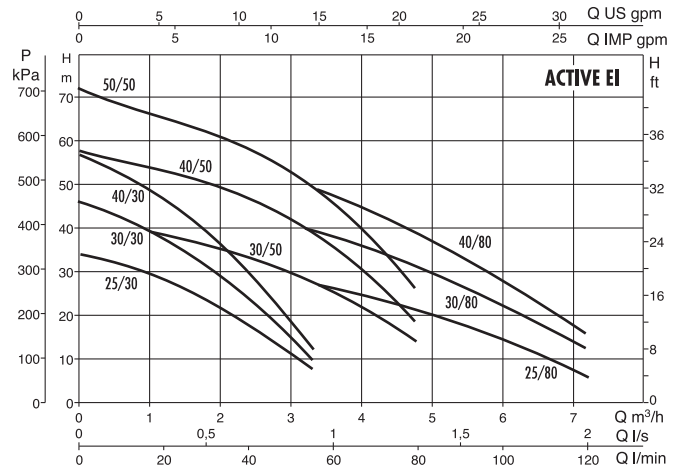
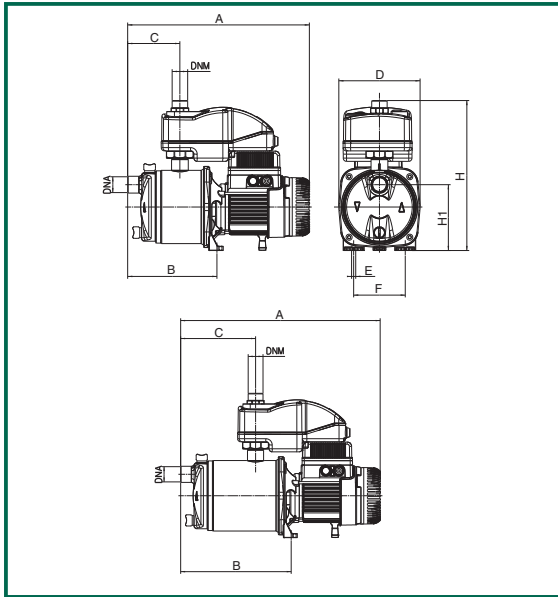

MODEL	A	B	C	D	E	F	H	H1	DNA	DNM	PACKING DIMENSIONS			WEIGHT Kg
											A	B	C	
ACTIVE EI 25/30 M	390	192	112	174	9	111	322	141	1" G	1" G	476	234	348	10,90
ACTIVE EI 30/30 M	445	247	167	174	9	111	322	141	1" G	1" G	476	234	348	13,50
ACTIVE EI 40/30 M	445	247	167	174	9	111	322	141	1" G	1" G	476	234	348	14,00
ACTIVE EI 30/50 M	390	192	112	174	9	111	322	141	1" G	1" G	476	234	348	10,00
ACTIVE EI 40/50 M	445	247	167	174	9	111	322	141	1" G	1" G	476	234	348	15,50
ACTIVE EI 50/50 M	445	247	167	174	9	111	322	141	1" G	1" G	476	234	348	16,00
ACTIVE EI 25/80 M	390	192	112	174	9	111	322	141	1" G	1" G	476	234	348	9,50
ACTIVE EI 30/80 M	445	247	167	174	9	111	322	141	1" G	1" G	476	234	348	15,50
ACTIVE EI 40/80 M	445	247	167	174	9	111	322	141	1" G	1" G	476	234	348	16,00

MODEL	ELECTRICAL DATA							HYDRAULIC DATA (n ≈ 2800 1/min)																		
	VOLTAGE 50 Hz	P1 MAX kW	P2 NOMINAL		I _n A	CAPACITOR		Q m³/h l/min	H (m)																	
			kW	HP		μF	V _c		0	0,6	1,2	1,8	2,4	3,0	3,6	4,2	4,8	6	7,2							
ACTIVE EI 25/30 M	1x220-240 V ~	0,520	0,37	0,5	2,4	10	450	34,5	31,7	28,3	23,5	17,5	11													
ACTIVE EI 30/30 M	1x220-240 V ~	0,720	0,45	0,6	3,2	12,5	450	46	42,2	37,8	31,2	23,3	14,3													
ACTIVE EI 40/30 M	1x220-240 V ~	0,880	0,55	0,75	3,9	12,5	450	57	52,7	47	38,8	29	17,7													
ACTIVE EI 30/50 M	1x220-240 V ~	0,880	0,55	0,75	3,9	12,5	450	42,2	40,2	38,2	36,2	33,8	30	24,8	19,5	14										
ACTIVE EI 40/50 M	1x220-240 V ~	1,200	0,8	1,1	5,3	20	450	57,7	55,3	52,8	50,1	47,1	42,7	35,8	28	19,2										
ACTIVE EI 50/50 M	1x220-240 V ~	1,480	1	1,36	6,3	25	450	72	68,5	65,5	62,1	58,2	52,2	43,6	34,5	26										
ACTIVE EI 25/80 M	1x220-240 V ~	0,880	0,55	0,75	3,9	12,5	450	34		33	32	30,5	28,5	26	23,5	21	14,5	6,5								
ACTIVE EI 30/80 M	1x220-240 V ~	1,200	0,8	1,1	5,3	20	450	47,3		46,5	45	43,5	41	38	34,5	31	23	12								
ACTIVE EI 40/80 M	1x220-240 V ~	1,480	1	1,36	6,3	20	450	59		57	56	54	51	47	43,5	39	29,5	16,5								

The performance curves are based on the kinematic viscosity values = 1 mm²/s and density equal to 1000 Kg/m³. Curve tolerance according to ISO 9906.

ACTIVE EC

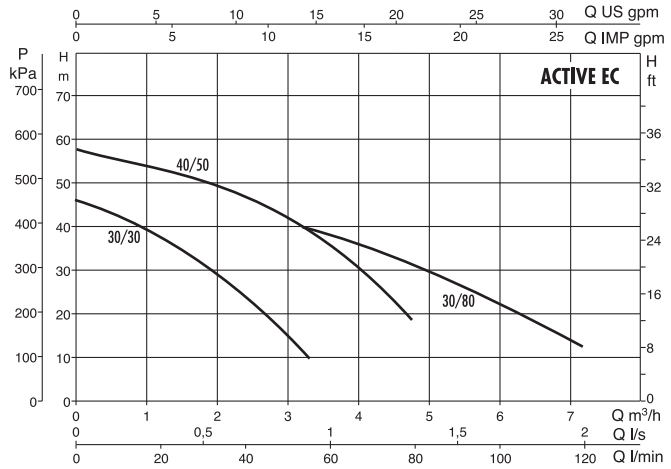
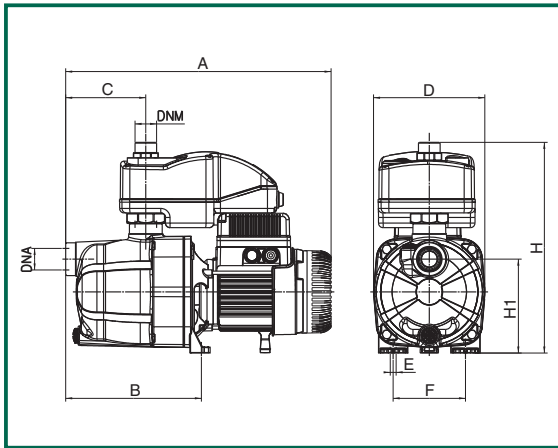

MODEL	A	B	C	D	E	F	H	H1	DNA	DNM	PACKING DIMENSIONS			WEIGHT Kg
											A	B	C	
ACTIVE EC 30/30 M	406	208	122	170	9	111	322	144	1" G	1" G	476	234	348	9,00
ACTIVE EC 40/50 M	406	208	122	170	9	111	322	144	1" G	1" G	476	234	348	11,00
ACTIVE EC 30/80 M	406	208	122	170	9	111	322	144	1" G	1" G	476	234	348	11,00

MODEL	ELECTRICAL DATA						HYDRAULIC DATA (n = 2800 1/min)																		
	VOLTAGE 50 Hz	P1 MAX kW	P2 NOMINAL		In A	CAPACITOR		Q																	
			kW	HP		μF	Vc	m³/h	0	0,6	1,2	1,8	2,4	3,0	3,6	4,2	4,8	6	7,2						
ACTIVE EC 30/30 M	1x220-240 V ~	0,720	0,45	0,6	3,2	12,5	450	46	42,2	37,8	31,2	23,3	14,3												
ACTIVE EC 40/50 M	1x220-240 V ~	1,200	0,8	1,1	5,3	20	450	57,7	55,3	52,8	50,1	47,1	42,7	35,8	28	19									
ACTIVE EC 30/80 M	1x220-240 V ~	1,200	0,8	1,1	5,3	20	450	47		46,5	45	43,5	41	38	34,5	31	23	12							

ACTIVE DRIVER



GENERAL DATA

Applications

Active Driver is an innovative integrated system for controlling variable-speed electric pumps by keeping pressure constant at variable flow rates. The user-friendly interface makes it quick and easy to calibrate pressure set points and view settings and error messages.

Constructional features of the pump

Active Driver comprises:

- an inverter
- a pressure sensor
- a flow sensor

It has 3 inputs and 2 outputs so as to be able to realise certain interface solutions with more complex installations.

Cooling: water flow through the whole device and cools down the components.

Advantages of Active Driver:

- enhanced comfort
- energy saving
- silent-running
- compact
- overpressures eliminated
- extended pump lifetime
- trouble-free installation
- compatible with a large number of pump types

The ACTIVE DRIVER is supplied already set up for installation in the following models:

ACTIVE DRIVER M/M:

fed with a single-phase line, controls electropumps with a 230V standard three-phase asynchronous motor.

ACTIVE DRIVER M/T:

fed with a single-phase line, controls electropumps with a 230V standard single-phase asynchronous motor.

ACTIVE DRIVER T/T:

fed with a three-phase line, controls electropumps with a 400V standard three-phase asynchronous motor.

ENERGY SAVING:

Test performed with a 1.1kW pump with head set to 30 mca.

FLOW (l/min.)	STATISTIC FLOW OPERATION	DIRECT CONNECTION CONSUMPTION kW	CONSUMPTION WITH ACTIVE DRIVER kW	POWER DIFFERENCE	ENERGY SAVED IN A YEAR (8760 hours) kW
5	20%	1,295	0,185	1,110	1.945
10	40%	1,388	0,555	0,833	2.917
20	20%	1,480	0,740	0,740	1.296
40	9%	1,573	1,110	0,463	365
70	6%	1,794	1,570	0,224	118
100	5%	1,850	1,850	0,000	0
TOTAL ANNUAL SAVING kW					6.641

PROTECTIONS:

Active Driver features a malfunction protection system. Any fault is indicated on the display and, depending on the type of error, the pump may switch off. The application provides:

- dry running
- overload
- excess temperature of the electronics
- abnormal feeding voltages (excluding A.D. M/M and A.D. M/T 1.0)
- direct short-circuit between the output phases

ELECTRICAL DATA

MODEL	MAX CURRENT OF MOTOR A	MAX MOTOR POWER kW	MAIN SUPPLY VOLTAGE 50-60 Hz	PUMP SUPPLY VOLTAGE	Ø DNA	Ø DNM	CONNECTIVITY FOR PARALLEL WORKING	TO BE USED WITH PUMPS TYPE	OVERALL DIMENSIONS		
ACTIVE DRIVER M/M 1.1	8,5	1,1	Single-Phase 1x230	Single-Phase 1x230	1 1/4" M	1 1/2" F	NO	All surface pumps, submersible pumps and Pulsar 5" with Single Phase motor with 8,5 Ampere Max Input Current	22	28	18
ACTIVE DRIVER M/T 1.0	4,7	1,0	Single-Phase 1x230	Three-Phase 3x230	1 1/4" M	1 1/2" F	YES	All surface pumps, submersible pumps and Pulsar 5" with 230 V Three Phase motor with 4,7 Ampere Max Input Current			
ACTIVE DRIVER M/T 2.2	9,3	2,2	Single-Phase 1x230	Three-Phase 3x230	1 1/4" M	1 1/2" F	YES	All surface pumps, submersible pumps and Pulsar 5" with 230 V Three Phase motor with 9,3 Ampere Max Input Current			
ACTIVE DRIVER T/T 3.0	7,5	3,0	Three-Phase 3x400	Three-Phase 3x400	1 1/4" M	1 1/2" F	YES	All surface pumps, submersible pumps and Pulsar 5" with 400 V Three Phase motor with 7,5 Ampere Max Input Current			
ACTIVE DRIVER T/T 5.5	13,3	5,5	Three-Phase 3x400	Three-Phase 3x400	1 1/4" M	1 1/2" F	YES	All surface pumps, submersible pumps and Pulsar 5" with 400 V Three Phase motor with 13,3 Ampere Max Input Current			

MODEL	WEIGHT (Kg)	INSTALLATION	MAX FLUID TEMPERATURE	MAX WORKING TEMPERATURE	MAX PRESSURE (bar)	REGULATING RANGE (bar)	FLUID INPUT HYDRAULIC COUPLING	FLUID OUTPUT HYDRAULIC COUPLING	DEGREE OF PROTECTION
ACTIVE DRIVER M/M 1.1	4	ANY POSITION	50°C	60°C	16	from 1 to 6	1 1/4" male	1 1/2" female	IP 55
ACTIVE DRIVER M/T 1.0	3,8	ANY POSITION	50°C	60°C	16	from 1 to 9	1 1/4" male	1 1/2" female	IP 55
ACTIVE DRIVER M/T 2.2	3,8	ANY POSITION	50°C	60°C	16	from 1 to 15	1 1/4" male	1 1/2" female	IP 55
ACTIVE DRIVER T/T 3.0	5	FACING UPWARD	50°C	60°C	16	from 1 to 15	1 1/4" male	1 1/2" female	IP 55
ACTIVE DRIVER T/T 5.5	5	FACING UPWARD	50°C	60°C	16	from 1 to 15	1 1/4" male	1 1/2" femmina female	IP 55

DIAGRAM OF PRESSURE LOSSES

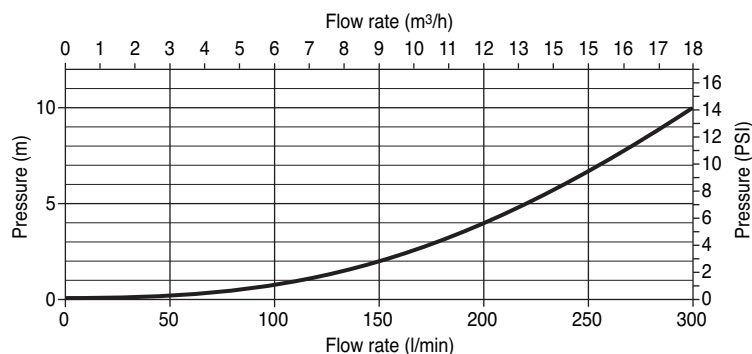

OPERATION DATA

PARALLEL INSTALLATION

Operation logic:

The parallel installation operation logic is that of supplying **Constant Pressure to the varying flow rate of the water** required by the system: this is made possible by the Active Driver which is applied to each pump.

Each pump should ideally be set at the same desired pressure value.

The first pump is started when the pressure in the system drops for the first time, due to the drawing of water. The second and/or third pump start **in cascade** as the flow rate increases. As the flow rate of the water decreases, the pumps turn off in reverse order to which they were started.

Thanks to an **alternating** system in which the pumps are started, the **second pump** is started when the pressure in the system drops for a second time. The first and/or third pump start **in cascade** as the flow rate increases. As the flow rate of the water decreases, the pumps turn off in reverse order to which they were started.

PARAMETERS FOR THE USER

Setting the set point pressure (in bar):

From normal operating status, hold down the MODE and SET keys simultaneously until the letters SP appear on the display. In these conditions the + and – keys allow you respectively to increase and decrease the desired pressure value. The regulating range is from 1,0 to 9,0 bar. Press SET to return to normal operating status.

SP is related to 2 parameters (already set but modifiable by the user)

RP: expresses in metres the decrease in pressure that makes the pump start.

DP: expresses in metres the desired decrease in pressure at low flow rates.

PARAMETERS FOR THE INSTALLER

From normal operating status, hold down the MODE & SET & - keys simultaneously until the letters “rC” appear on the display. In these conditions the + and – keys allow you respectively to increase and decrease the value of the parameter while the MODE key allows you to move on to the next parameter in cyclic mode. Press SET to return to normal operating status.

rC: Setting the rated current of the electropump.

This parameter must be set the same as the current on the motor data plate in the configuration in which it is used, with power supply 230V.

rt: Setting the direction of rotation.

Possible values: 0 and 1. If the direction of rotation of the electropump is not correct, it is possible to invert the direction of rotation by changing this parameter.

RESETTING ERROR CONDITIONS

For some malfunctions and shutdowns, the system makes a certain number of attempts to automatically reset the pump.

The following table shows the sequences of the operations performed by Active Driver for the various kinds of shutdown:

AUTOMATIC RESETS OF ERROR CONDITIONS		
DISPLAY INDICATION	DESCRIPTION	SEQUENCE OF AUTOMATIC RESET
bL	Blockage due to water lack	- An attempt every 10 minutes for a total of 6 attempts - An attempt every 1 hour for a total of 24 attempts - An attempt every 24 hours for a total of 30 attempts
bP	Blockage due to fault of the pressure sensor	- Reset 10 seconds after correct conditions return
LP	Blockage due to low supply voltage	- Reset when voltage returns to a value in the range 220V - 20% + 10%
HP	Blockage due to high voltage	- Reset when the internal voltage returns in acceptable conditions
Ot	Blockage due to overheating of the power stages	- Reset when the temperature of the power stages falls below 70°C again
OC	Blockage due to current overload	- An attempt every 10 minutes for a total of 6 attempts
oF	Blockage due to current overload in the output stages	- An attempt every 10 minutes for a total of 6 attempts
oF/ot	Blockage due to current overload in the output stages with temperature of the stages higher than 45°C	- An attempt every 10 minutes or when the temperature has fallen by 10°C

Identifying s.	Description	Factory parameters				
		A.D. M/M 1.1	A.D. M/T 1.0	A.D. M/T 2.2	A.D. T/T 3.0	A.D. T/T 5.5
Go	Electropump operating					
Sb	Electropump waiting					
	User displays and settings (keys MODE and SET 2 seconds)					
SP	Setting the set-point pressure (in bar). Default : 3 bar	3.0 bar	3.0 bar	3.0 bar	3.0 bar	3.0 bar
	Installer displays and settings (keys MODE and SET and – 5 seconds)					
rC	Setting the rated current of the electropump (in A)		0.0 A	0.0 A	0.0 A	0.0 A
rt	Setting the direction of rotation		00	00	00	00
Fn	Setting the rated rotation frequency of the electropump. (in Hz)	50	50	50	50	50
od	Setting the operating mode	01	01	01	01	01
rP	Setting the pressure drop for restarting (in bar)	0.5 bar	0.5 bar	0.5 bar	0.5 bar	0.5 bar
Ad	Setting the interconnection address (necessary on sets of several electropumps with exchange)		“_ _”	“_ _”	“_ _”	“_ _”
Eb	Enabling the booster		02	02	02	02
	Technical assistance displays and settings (keys MODE and SET and + 5 seconds)					
tb	Setting the reaction time of the water lack blockage (in s.)	10 s	10 s	10 s	10 s	10 s
GP	Setting the gain of the proportional coefficient of the PI	1.0	1.0	1.0	1.0	1.0
GI	Setting the gain of the integral coefficient of the PI	1.0	1.0	1.0	1.0	1.0
FS	Setting the maximum rotation frequency of the electropump (in Hz)	50	50	50	50	50
FL	Setting the minimum rotation frequency of the electropump. (in Hz)	0	0	0	0	0
Ft	Setting the low flow rate threshold	15	15	15	15	15
CM	Exchange method on sets of 2 electropumps		01	01	01	01
AE	Setting the enabling of the anti-block/anti-frost function	01	01	01	01	01
SF	Setting the starting frequency	45				
St	Setting the starting time	1.0				
i 1	Setting the function of input 1 (float)			01	01	01
i 2	Setting the function of input 2 (set point selection)			01	01	01
i 3	Setting the function of input 3 (enable)			01	01	01
P1	Setting the auxiliary setpoint pressure (in bar) - in function of input 2 -			2.5 bar	2.5 bar	2.5 bar
o1	Setting the function of output 1 (default value: 2; function: ON alarm)			02	02	02
o2	Setting the function of output 2 (default value: 2; function: ON operating)			02	02	02
	Displays of the main values (MODE key)					
Fr	Display of the current rotation frequency (in Hz)					
UP	Display of pressure (in bar)					
C1	Display of the phase current of the electropump (in A)					
UE	Display of the version of the software with which the appliance is equipped					
	DISPLAY (keys SET and – for 2 seconds)					
UF	Display of the flow					
ZF	Display of zero flow					
FM	Display of the maximum rotation frequency (in Hz)					
tE	Display of the temperature of the power stages (in °C)					
bt	Display of the temperature of the electronic card (in °C)					
GS	Display of running status					
FF	Display of the log of errors and blockages					
	Access to manual mode (keys SET and + and – 5 seconds)					
FP	Setting the test frequency in manual mode (in Hz) ≤ the set value FS	40	40	40	40	40
UP	Pressure display (in bar)					
C1	Display of electropump phase current (in A)					
rt	Setting the direction of rotation					
UF	Display of flow					
ZF	Display of zero flow					
	System reset (keys MODE and SET and + and –)					
ZF	General reset (ZF appears when leaving reset and restarting)					

Identifying s.	Description	Factory parameters				
		A.D. M/M 1.1	A.D. M/T 1.0	A.D. M/T 2.2	A.D. T/T 3.0	A.D. T/T 5.5
	Restoring the factory settings (keys SET and + for 2 seconds when switching on)					
EE	Saving and reading the factory settings on the EEprom					
	Error and status conditions					
bL	Blockage due to water lack					
bP	Blockage due to absence of pressure sensor					
LP	Blockage due to low supply voltage					
HP	Blockage due to high supply voltage					
ot	Blockage due to overheating of the power stages					
oC	Blockage due to current overload in the electropump motor					
oF	Blockage due to current overload in the output stages					
oF/ot	Blockage due to current overload in the output stages with temperature of the stages higher than 45°C					
SC	Blockage due to short circuit in the output stages					
EC	Blockage due to non setting of the rated current (rC) or of the rated frequency (Fn)					
E0...E7	Internal error 0...7					
F1	Status / Alarm input 1					
F3	Status / Alarm input 3					

- Setting the pump current:

To set the current, enter the installer menu by pressing the following key for 5 seconds:



The text rC is displayed

The value rC is read on the dataplate of the electric pump as the rated current in Ampere (A) and is entered using the keys and . Press the key.

- Setting the direction of rotation:

The text rt is displayed, after which use keys and to invert the direction of pump rotation. Press the key.

- Setting the nominal frequency:

The text Fn is displayed, after which use keys and to set the nominal frequency of the pump in Hz according to the pump dataplate specifications; e.g. 50Hz for the European market. Press the key.

- Setting the pressure Setpoint:

The factory-set value is 3.0 bar.

To change it, press the buttons at the same time for 2 seconds.

appears on the display. Set the desired pressure in bar by pressing the buttons and .

Press the button to confirm and exit the menu.

AD JET - AD EURO



AD 1.0 M/T JETCOM 132M



AD 1.0 M/T EUROINOX 40/80M

GENERAL DATA

Automatic water lifting units, particularly suitable for domestic use, small installations for civil, agricultural, industrial use, washing and hobby applications.

The units are characterised by the use of: JET, JETINOX, JETCOM e EUROINOX, directly coupled with the Active Driver device.

The Active Driver device is an innovative variable speed electric pump integrated control system, capable of maintaining a constant pressure in relation to the varied flow rates. The set pressure can be adjusted and the various settings and related error warnings can be viewed, thanks to a simple and immediate user interface. Active Driver include an inverter, a pressure sensor and the flow sensor.

- Liquid temperature range: from 0°C to +35°C for domestic use
from 0°C to +40°C for other uses
- clean, free from solid or abrasive substances, not viscous, not aggressive, not crystallised, chemically neutral and close to the characteristics of water.

The performance curves are based on the kinematic viscosity values = 1 mm²/s and density equal to 1000 Kg/m³. Curve tolerance according to ISO 9906.

AD JET

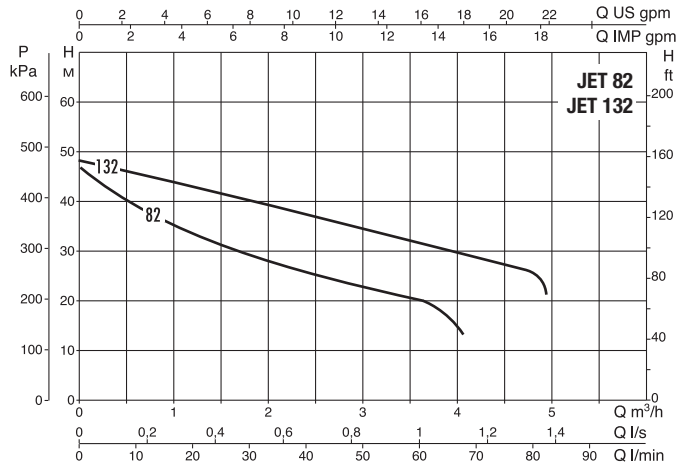
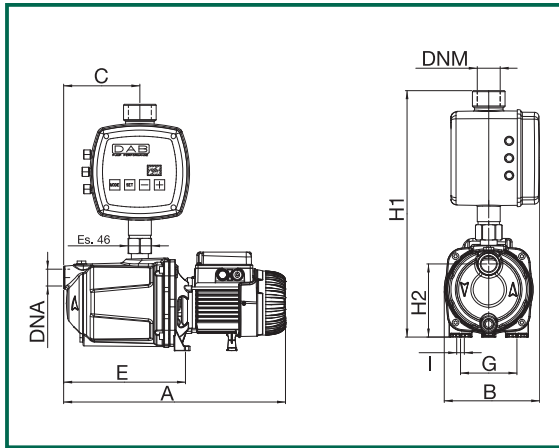

MODEL	A	B	C	E	G	I	H1	H2	DNA	DNM	PACKING VOLUME m ³	WEIGHT Kg
AD1.0 M/T JET 82M	395	185	108	192	111	9	485	144	1"G	1"½ G	0,54	15,9
AD1.0 M/T JET 132M	414	185	108	192	111	9	485	144	1"G	1"½ G	0,54	18,8

MODEL	ELECTRICAL DATA						HYDRAULIC DATA (n ≈ 2800 1/min)																
	VOLTAGE 50 Hz	P1 MAX kW	P2 NOMINAL		In A	CAPACITOR																	
			kW	HP		μF	Vc																
AD1.0 M/T JET 82M	1x220-240 V ~	0,850	0,6	0,8	3,8	12,5	450	H (m)	47	40	34	30	26,2	23,5	20,3								
AD1.0 M/T JET 132M	1x220-240 V ~	1,490	1,0	1,36	6,6	25	450		48	45,6	42,8	40	37,6	35	32,5	30	27						

The performance curves are based on the kinematic viscosity values = 1 mm²/s and density equal to 1000 Kg/m³. Curve tolerance according to ISO 9906.

AD JETINOX

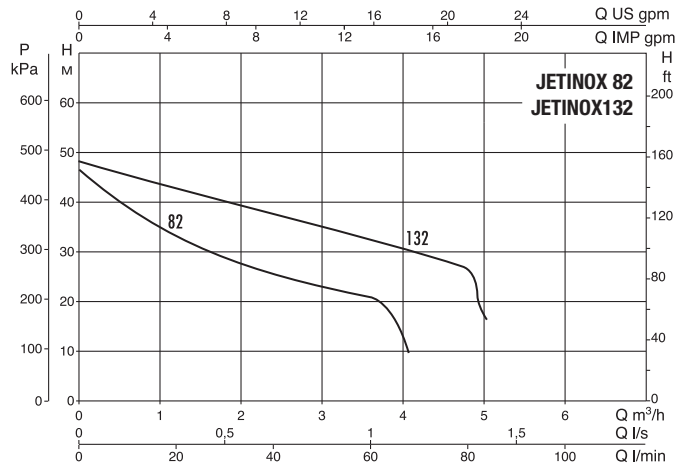
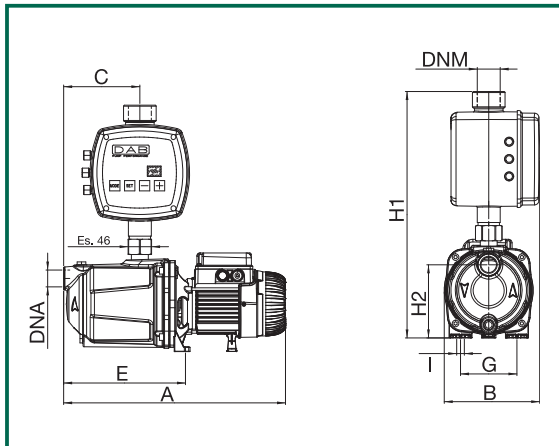

MODEL	A	B	C	E	G	I	H1	H2	DNA	DNM	PACKING VOLUME m ³	WEIGHT Kg
AD1.0M/T JETINOX 82M	406	187	122	207	111	9	502	144	1"G	1"½ G	0,54	13,2
AD1.0M/T JETINOX 132M	424	187	122	207	111	9	502	144	1"G	1"½ G	0,54	16,2

MODEL	ELECTRICAL DATA						HYDRAULIC DATA (n ≈ 2800 1/min)																
	VOLTAGE 50 Hz	P1 MAX kW	P2 NOMINAL		In A	CAPACITOR																	
			kW	HP		μF	Vc																
AD1.0M/T JETINOX 82M	1x220-240 V ~	0,850	0,6	0,8	3,8	12,5	450	H (m)	47	40	34	30	26,2	23,5	20,3								
AD1.0M/T JETINOX 132M	1x220-240 V ~	1,490	1,0	1,36	6,6	25	450		48	45,6	42,8	40	37,6	35	32,5	30	27						

The performance curves are based on the kinematic viscosity values = 1 mm²/s and density equal to 1000 Kg/m³. Curve tolerance according to ISO 9906.

AD JETCOM

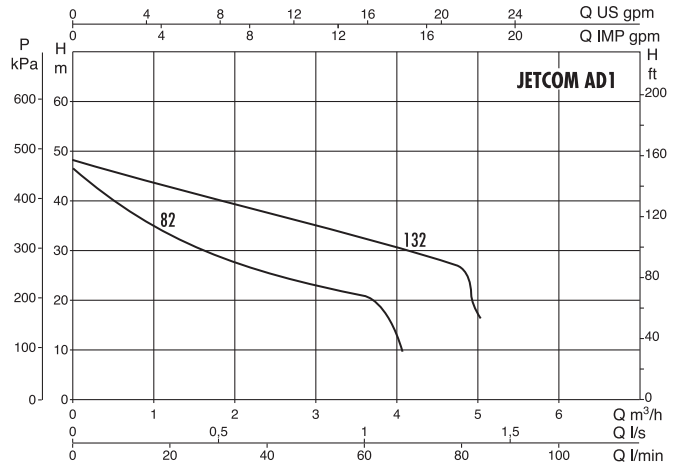
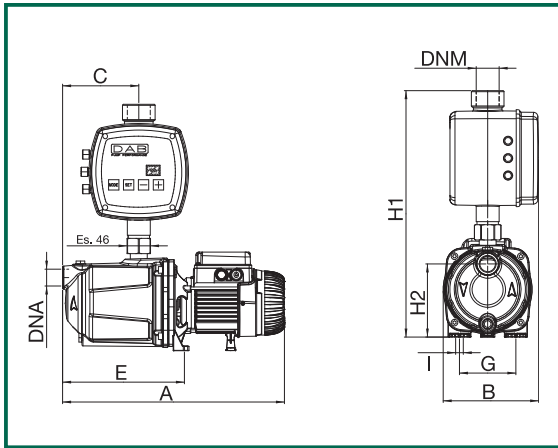

MODEL	A	B	C	E	G	I	H1	H2	DNA	DNM	PACKING VOLUME m ³	WEIGHT Kg
AD1.0M/T JETCOM 82M	406	185	122	208	111	9	503	144	1" G	1 1/2" G	0,54	10,7
AD1.0M/T JETCOM 132M	425	185	122	208	111	9	502	144	1" G	1 1/2" G	0,54	16,1

MODEL	ELECTRICAL DATA						HYDRAULIC DATA (n = 2800 1/min)																		
	VOLTAGE 50 Hz	P1 MAX kW	P2 NOMINAL		In A	CAPACITOR																			
			kW	HP		μF	Vc	0	0.6	1.2	1.8	2.4	3.0	3.6	4.2	4.8	6	7.2							
AD1.0M/T JETCOM 82M	1x220-240 V ~	0,850	0,6	0,8	3,8	12,5	450	H (m)	47	40	34	30	26,2	23,5	20,3										
AD1.0M/T JETCOM 132M	1x220-240 V ~	1,490	1,0	1,36	6,6	25	450	H (m)	48	45,6	42,8	40	37,6	35	32,5	30	27								

The performance curves are based on the kinematic viscosity values = 1 mm²/s and density equal to 1000 Kg/m³. Curve tolerance according to ISO 9906.

AD EURO

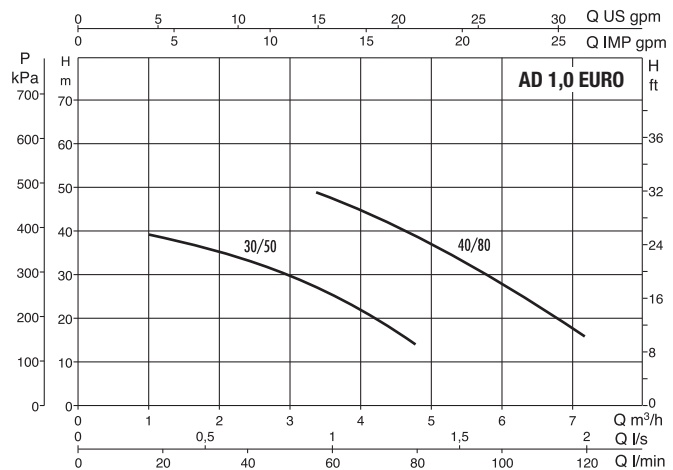
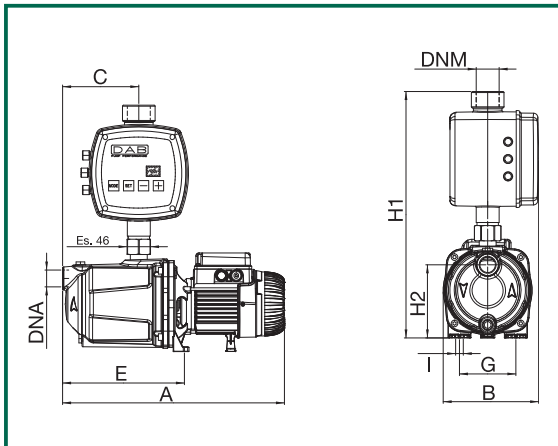

MODEL	A	B	C	E	G	I	H1	H2	DNA	DNM	PACKING VOLUME m ³	WEIGHT Kg
AD1.0M/T EURO 30/50M	378	187	95	235	111	9	485	144	1" G	1 1/2" G	0,54	16,8
AD1.0M/T EURO 40/80M	452	187	150	235	111	9	485	144	1" G	1 1/2" G	0,54	21,6

MODEL	ELECTRICAL DATA						HYDRAULIC DATA (n = 2800 1/min)																		
	VOLTAGE 50 Hz	P1 MAX kW	P2 NOMINAL		In A	CAPACITOR																			
			kW	HP		μF	Vc	0	0.6	1.2	1.8	2.4	3.0	3.6	4.2	4.8	6	7.2							
AD1.0M/T EURO 30/50M	1x220-240 V ~	0,88	0,55	0,75	3,9	12,5	450	H (m)	42,2	40,2	38,2	36,2	33,8	30	24,8	19,5	14								
AD1.0M/T EURO 40/80M	1x220-240 V ~	1,48	1,0	1,36	6,3	25	450	H (m)	59	58	57	56	54	51	47,5	43,8	39,5	29,5	16						

The performance curves are based on the kinematic viscosity values = 1 mm²/s and density equal to 1000 Kg/m³. Curve tolerance according to ISO 9906.

AD EUROINOX

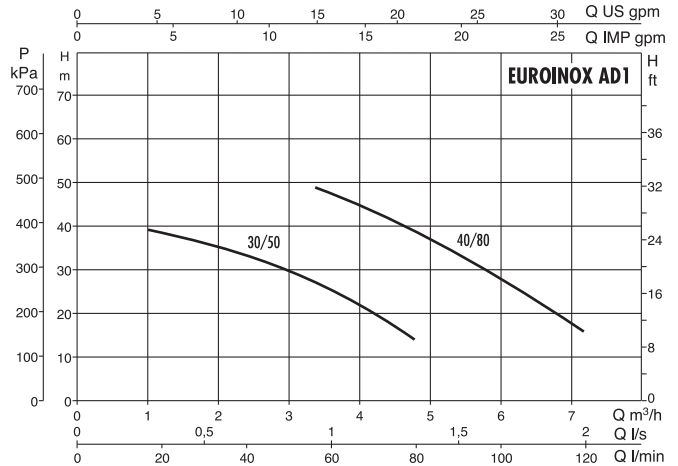
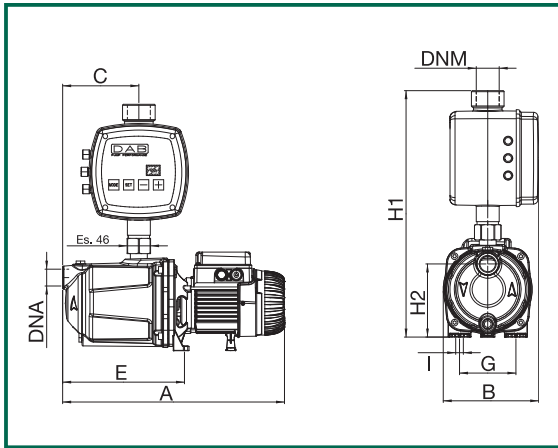

MODEL	A	B	C	E	G	I	H1	H2	DNA	DNM	PACKING VOLUME m ³	WEIGHT Kg
AD1.0M/T EUROINOX 30/50M	384	187	108	186	111	9	503	144	1"G	1"½ G	0,54	14,4
AD1.0M/T EUROINOX 40/80M	458	187	166	241	111	9	503	144	1"G	1"½ G	0,54	17,4

MODEL	ELECTRICAL DATA						HYDRAULIC DATA (n ≈ 2800 1/min)																
	VOLTAGE 50 Hz	P1 MAX kW	P2 NOMINAL		In A	CAPACITOR																	
			kW	HP		μF	Vc	0	0,6	1,2	1,8	2,4	3,0	3,6	4,2	4,8	6	7,2					
AD1.0M/T EUROINOX 30/50M	1x220-240 V ~	0,88	0,55	0,75	3,9	12,5	450	H (m)	42,2	40,2	38,2	36,2	33,8	30	24,8	19,5	14						
AD1.0M/T EUROINOX 40/80M	1x220-240 V ~	1,48	1,0	1,36	6,3	25	450		59	58	57	56	54	51	47,5	43,8	39,5	29,5	16				

The performance curves are based on the kinematic viscosity values = 1 mm²/s and density equal to 1000 Kg/m³. Curve tolerance according to ISO 9906.

AD EUROCOM

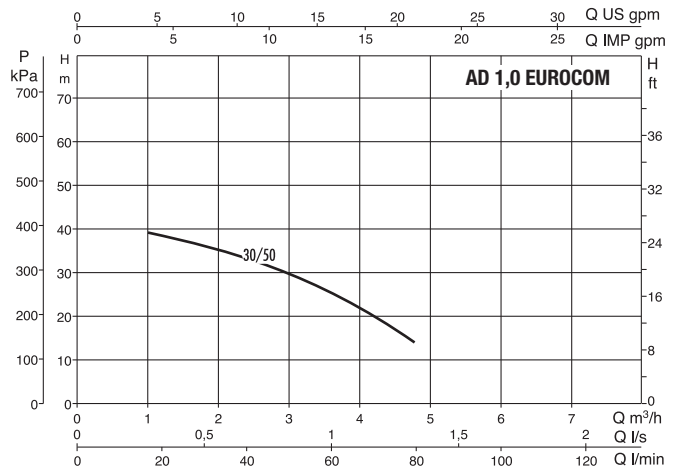
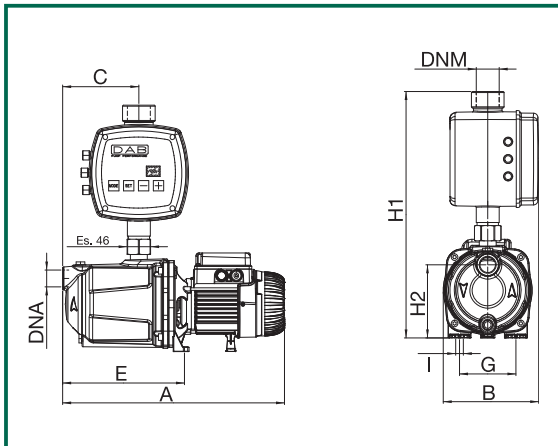

MODEL	A	B	C	E	G	I	H1	H2	DNA	DNM	PACKING VOLUME m ³	WEIGHT Kg
AD1.0M/T EUROCOM 30/50M	406	185	122	208	111	9	503	144	1"G	1"½ G	0,54	9,3

MODEL	ELECTRICAL DATA						HYDRAULIC DATA (n ≈ 2800 1/min)																
	VOLTAGE 50 Hz	P1 MAX kW	P2 NOMINAL		In A	CAPACITOR																	
			kW	HP		μF	Vc	0	0,6	1,2	1,8	2,4	3,0	3,6	4,2	4,8	6	7,2					
AD1.0M/T EUROCOM 30/50M	1x220-240 V ~	0,88	0,55	0,75	3,9	12,5	450	H (m)	42,2	40,2	38,2	36,2	33,8	30	24,8	19,5	14						

AQUAJET

AUTOMATIC SELF-PRIMING BOOSTER SETS

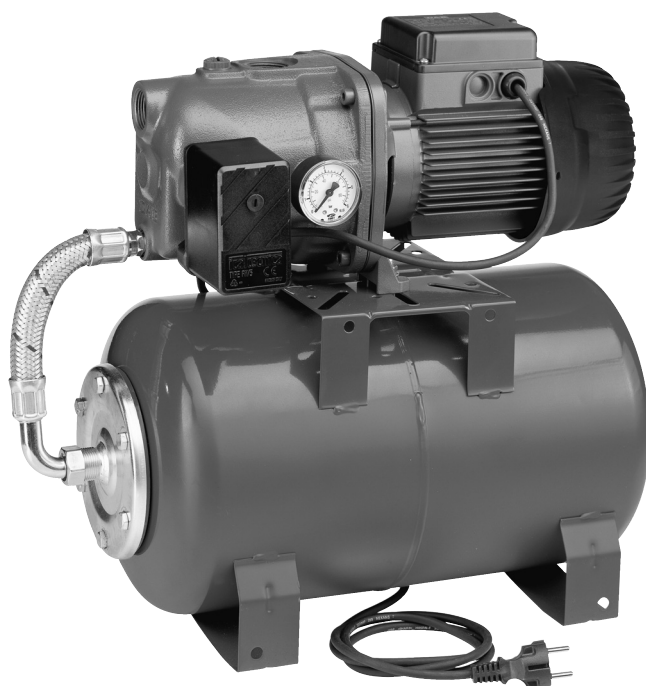

GENERAL DATA

Applications

Automatic water lifting sets, particularly suitable for domestic use, small installations for civil, industrial and agricultural use, washing systems and hobbies.

These are characterised by the use of JET self-priming electropumps which can operate even when there is air, gas and small quantities of sand in the water.

The set is composed of a diaphragm tank with 20 litres capacity, pressure switch for automatic operation, pressure gauge, JET electropump complete with power cable and plug, kit for coupling the pump and the tank, all assembled and ready for installation.

Constructional features of the pump

Die-cast aluminium pump body and motor support.

Technopolymer impeller, diffuser, Venturi tube and sand guard.

Stainless steel pressure discs.

Carbon/ceramic mechanical seal.

Constructional features of the motor

Induction motor, closed and cooled with external ventilation.

Rotor mounted on oversized greased sealed-for-life ball bearings to ensure silent running and long life.

Built-in thermal and current overload protection and a capacitor permanently in circuit.

Manufactured according to CEI 2-3 and CEI 61-69 standards (EN 60335-2-41).

Motor protection: IP 44

Terminal box protection: IP 55

Insulation class: F

Standard voltage: single-phase 220-240 V/50 Hz

Constructional features of the tank

Horizontal type, capacity 20 litres, with butyl diaphragm, complete with feet on the bottom and brackets for fixing the pump on top.

TECHNICAL DATA

N.	PARTS*	MATERIALS
1	PUMP BODY	CAST IRON 200 UNI ISO 185
3	SUPPORT	DIE-CAST ALUMINIUM
4	IMPELLER	TECHNOPOLYMER A
7	SHAFT WITH ROTOR	STAINLESS STEEL AISI 416 X12 CrS13 - UNI 6900/71
16	MECHANICAL SEAL	CARBON/CERAMIC
28	OR GASKET	NBR RUBBER
160	NOZZLE-VENTURI DIFFUSER ASSEMBLY	TECHNOPOLYMER A

* In contact with the liquid.

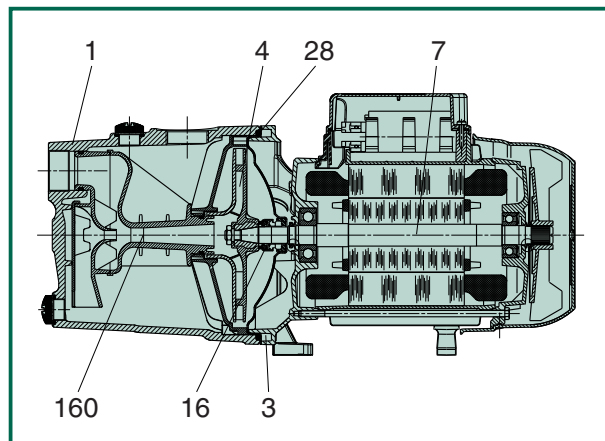

- Operating range: up to 5,4 m³/h with head up to 61 metres
- Liquid quality requirements: clean, free from solids or abrasive substances, non viscous, non aggressive, non crystallized, chemically neutral, close to the characteristics of water.
- Liquid temperature range: from 0°C to +35°C for domestic use (EN 60335-2-41)
from 0°C to +40°C for other uses.
- Maximum ambient temperature: +40°C
- Maximum operating pressure: 8 bar (800 kPa)
- Installation: fixed in a horizontal position

AQUAJET

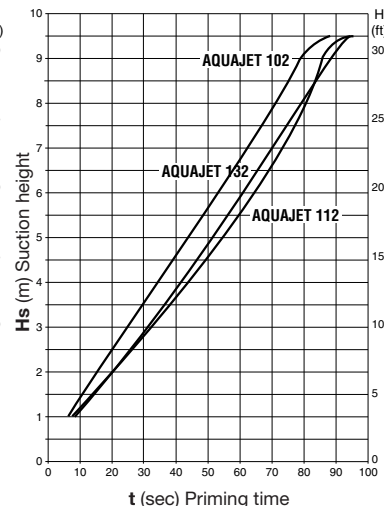
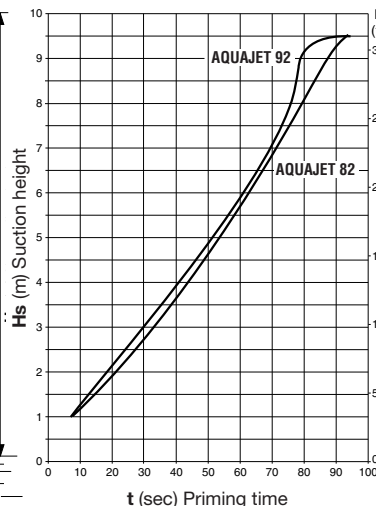
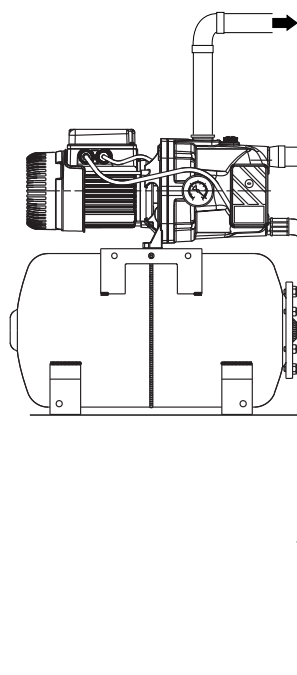

The performance curves are based on the kinematic viscosity values = 1 mm²/s and density equal to 1000 Kg/m³. Curve tolerance according to ISO 9906.
 Liquid temperature range: from 0 °C to +35°C
 Maximum ambient temperature: +40°C

AQUAJET

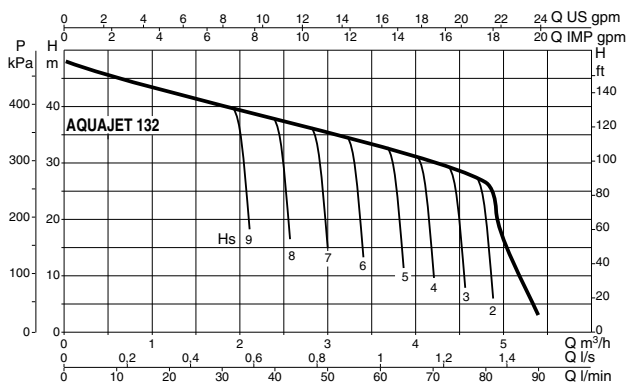
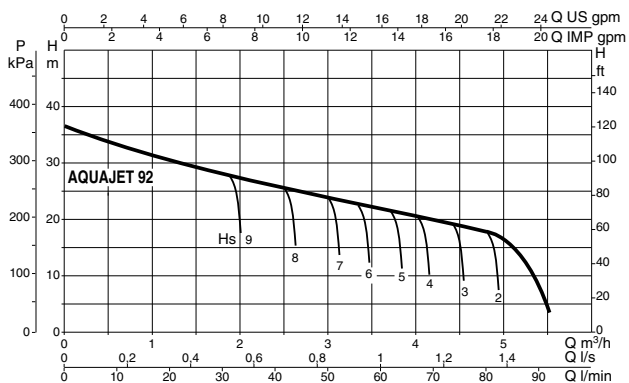
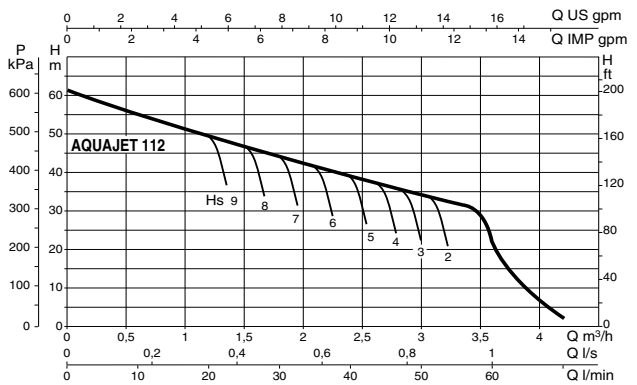
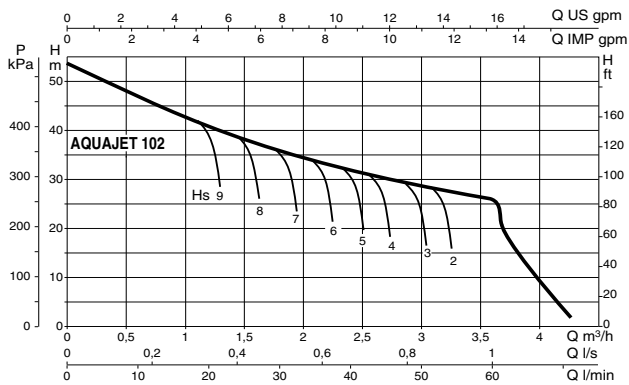
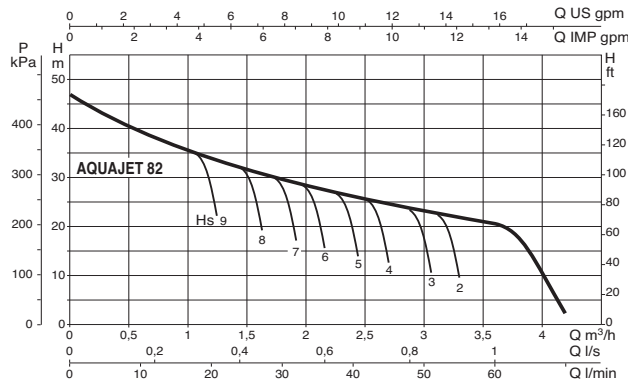
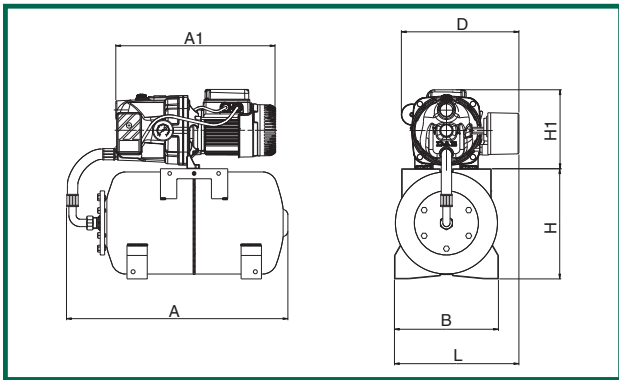

MODEL	A	A1	B	D	H	H1	L	PACKING DIMENSIONS			VOLUME m ³	WEIGHT Kg
								L/A	L/B	H		
AQUAJET 82 M	543	390	255	288	270	239	305	566	360	510	0,104	18,2
AQUAJET 102 M	543	409	255	293	270	239	305	566	360	510	0,104	20,0
AQUAJET 112 M	543	409	255	293	270	239	305	566	360	510	0,104	21,0
AQUAJET 92 M	543	390	255	288	270	239	305	566	360	510	0,104	19,2
AQUAJET 132 M	543	409	255	293	270	239	305	566	360	510	0,104	21,0

MODEL	ELECTRICAL DATA					HYDRAULIC DATA (n = 2850 1/min)														
	VOLTAGE 50 Hz	P1 MAX kW	P2 NOMINAL		In A	CAPACITOR		Q												
			kW	HP		μF	Vc	m ³ /h	0	0,6	1,2	1,8	2,4	3	3,6	4,2	4,8			
AQUAJET 82 M	1x220-240 V ~	0,85	0,6	0,8	3,8	12,5	450	H (m)	47	40	34	30	26,2	23,5	20,3					
AQUAJET 102 M	1x220-240 V ~	1,13	0,75	1	5,1	16	450		53,8	47	41	36,3	32,4	28,8	25,8					
AQUAJET 112 M	1x220-240 V ~	1,4	1	1,36	6,2	25	450		61	54	47,8	42,8	38,8	34,8	22					
AQUAJET 92 M	1x220-240 V ~	0,94	0,75	1	4,2	14	450		36,2	33,5	31	28,4	26	24	21,8	19,6	17,5			
AQUAJET 132 M	1x220-240 V ~	1,49	1	1,36	6,6	25	450		48	45,6	42,8	40	37,6	35	32,5	30	27			

AQUAJET-INOX

AUTOMATIC SELF-PRIMING BOOSTER SETS



GENERAL DATA

Applications

Automatic water lifting sets, particularly suitable for domestic use, small installations for civil, industrial and agricultural use, washing systems and hobbies.

These are characterised by the use of JETINOX self-priming electropumps which can operate even when there is air, gas and small quantities of sand in the water.

The set is composed of a diaphragm tank with capacity 20 litres, pressure switch for automatic operation, pressure gauge, JETINOX electropump complete with power cable and plug, kit for coupling the pump and the tank, all assembled and ready for installation.

Constructional features of the pump

Stainless steel pump body, seal cover and pressure disc.

Die-cast aluminium motor support.

Technopolymer impeller, diffuser and Venturi tube.

Carbon/ceramic mechanical seal.

Constructional features of the motor

Induction motor, closed and cooled with external ventilation.

Rotor mounted on oversized greased sealed-for-life ball bearings to ensure silent running and long life.

Built-in thermal and current overload protection and a capacitor permanently in circuit in the single-phase version.

Three-phase motors should be protected with a suitable overload protection complying with the regulations in force.

Manufactured according to CEI 2-3 and CEI 61-69 standards (EN 60335-2-41).

Motor protection: IP 44

Terminal box protection: IP 55

Insulation class: F

Standard voltage: single-phase 220-240 V/50 Hz

TECHNICAL DATA

N.	PARTS*	MATERIALS
1	PUMP BODY	STAINLESS STEEL AISI 304 X5 CrNi 1810 - UNI 6900/71
4	IMPELLER	TECHNOPOLYMER A
7	SHAFT WITH ROTOR	STAINLESS STEEL AISI 303 X10 CrNiS 1809 - UNI 6900/71
16	MECHANICAL SEAL	CARBON/CERAMIC
28	OR GASKET	NBR RUBBER
36	SEAL COVER	STAINLESS STEEL AISI 304 X5 CrNi 1810 - UNI 6900/71
160	NOZZLE-VENTURI DIFFUSER ASSEMBLY	TECHNOPOLYMER A

* In contact with the liquid.

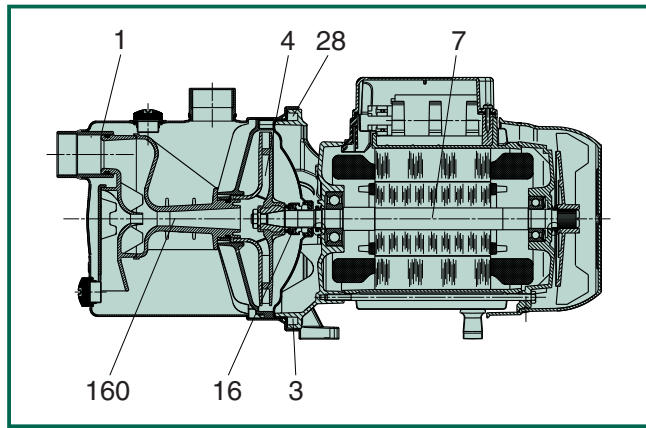

- Operating range: from 0.6 to 5.4 m³/h with head up to 61 metres
- Liquid quality requirements: clean, free from solids or abrasive substances, non viscous, non aggressive, non crystallized, chemically neutral, close to the characteristics of water.
- Liquid temperature range: from 0°C to +35°C for domestic use (EN 60335-2-41)
from 0°C to +40°C for other uses
- Maximum suction depth: 8 metres
- Maximum ambient temperature: +40°C
- Maximum operating pressure: 8 bar (800 kPa)
- Installation: fixed or portable in a horizontal position
- Special executions on request: other voltages and/or frequencies

Liquid temperature range: from 0 °C to +35°C

Maximum ambient temperature: +40°C

AQUAJET-INOX

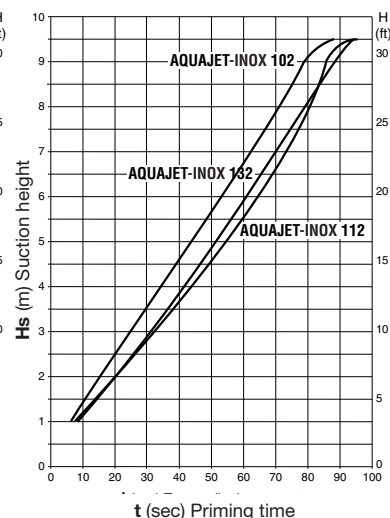
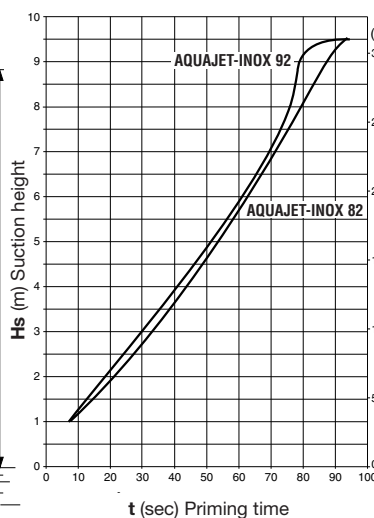
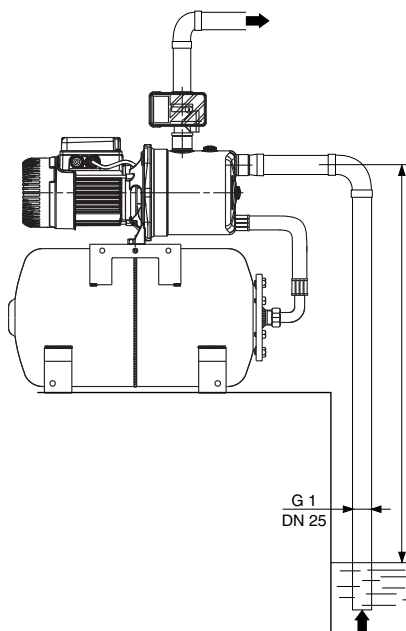

The performance curves are based on the kinematic viscosity values = 1 mm²/s and density equal to 1000 Kg/m³. Curve tolerance according to ISO 9906.

Liquid temperature range: from 0 °C to +35°C

Maximum ambient temperature: +40°C

AQUAJET-INOX

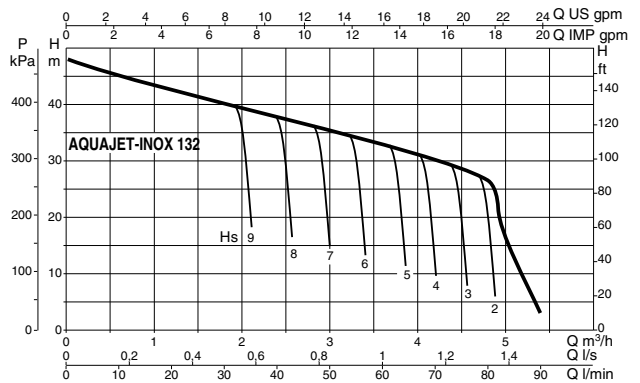
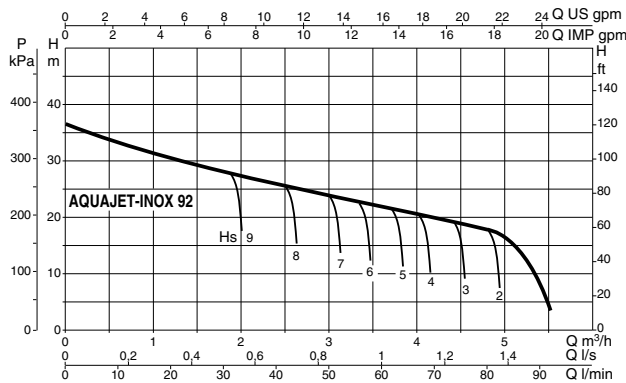
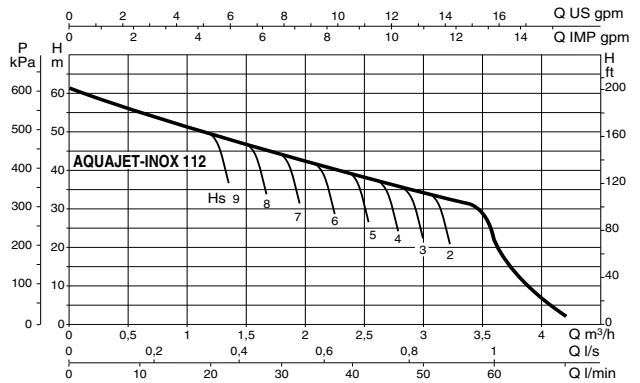
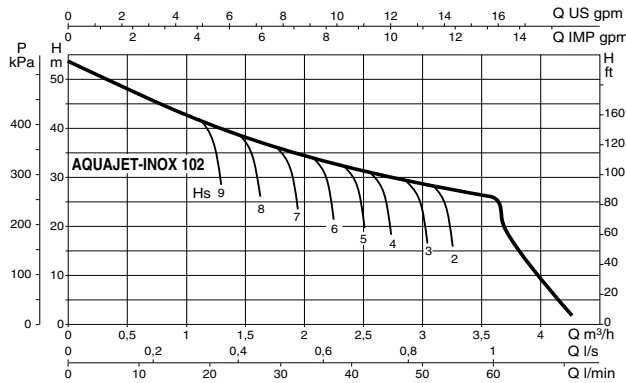
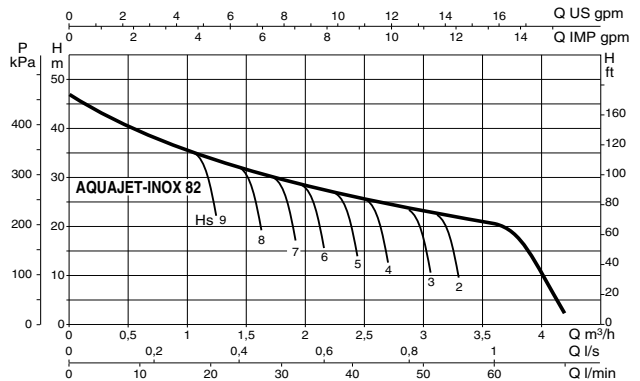
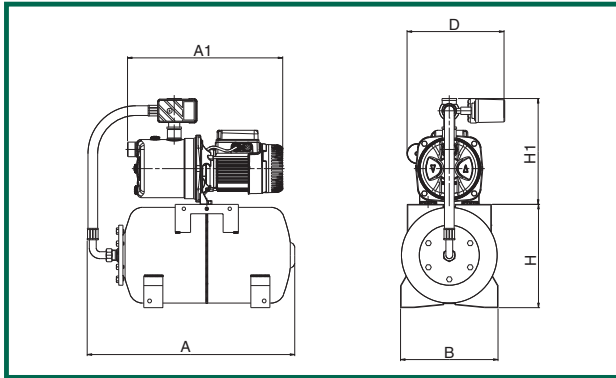

MODEL	A	A1	B	D	H	H1	L	PACKING DIMENSIONS			VOLUME m ³	WEIGHT Kg
								L/A	L/B	H		
AQUAJET-INOX 82 M	543	406	255	–	270	276	–	566	360	590	0,102	15,3
AQUAJET-INOX 102 M	543	424	255	260	270	276	–	566	360	590	0,102	17,1
AQUAJET-INOX 112 M	543	424	255	260	270	276	–	566	360	590	0,102	18,1
AQUAJET-INOX 92 M	543	406	255	–	270	276	–	566	360	590	0,102	15,3
AQUAJET-INOX 132 M	543	424	255	260	270	276	–	566	360	590	0,102	18,1

MODEL	ELECTRICAL DATA						HYDRAULIC DATA (n ≈ 2850 1/min)																		
	VOLTAGE 50 Hz	P1 MAX kW	P2 NOMINAL		In A	CAPACITOR μF Vc	Q																		
			MAX kW	HP			0	0,6	1,2	1,8	2,4	3	3,6	4,2	4,8										
AQUAJET-INOX 82 M	1x220-240 V ~	0,84	0,6	0,8	3,8	12,5	450	0	10	20	30	40	50	60	70	80	47	40	34	30	26,2	23,5	20,3		
AQUAJET-INOX 102 M	1x220-240 V ~	1,13	0,75	1	5,1	16	450	0	10	20	30	40	50	60	70	80	53,8	47	41	36,3	32,4	28,8	25,8		
AQUAJET-INOX 112 M	1x220-240 V ~	1,4	1	1,36	6,2	25	450	0	10	20	30	40	50	60	70	80	61	54	47,8	42,8	38,8	34,8	22		
AQUAJET-INOX 92 M	1x220-240 V ~	0,94	0,75	1	4,2	14	450	0	10	20	30	40	50	60	70	80	36,2	33,5	31	28,4	26	24	21,8	19,6	17,5
AQUAJET-INOX 132 M	1x220-240 V ~	1,45	1	1,36	6,6	25	450	0	10	20	30	40	50	60	70	80	48	45,6	42,8	40	37,6	35	32,5	30	27

GARDENJET - GARDEN-INOX - GARDEN-COM

ELECTROPUMPS FOR GARDENING

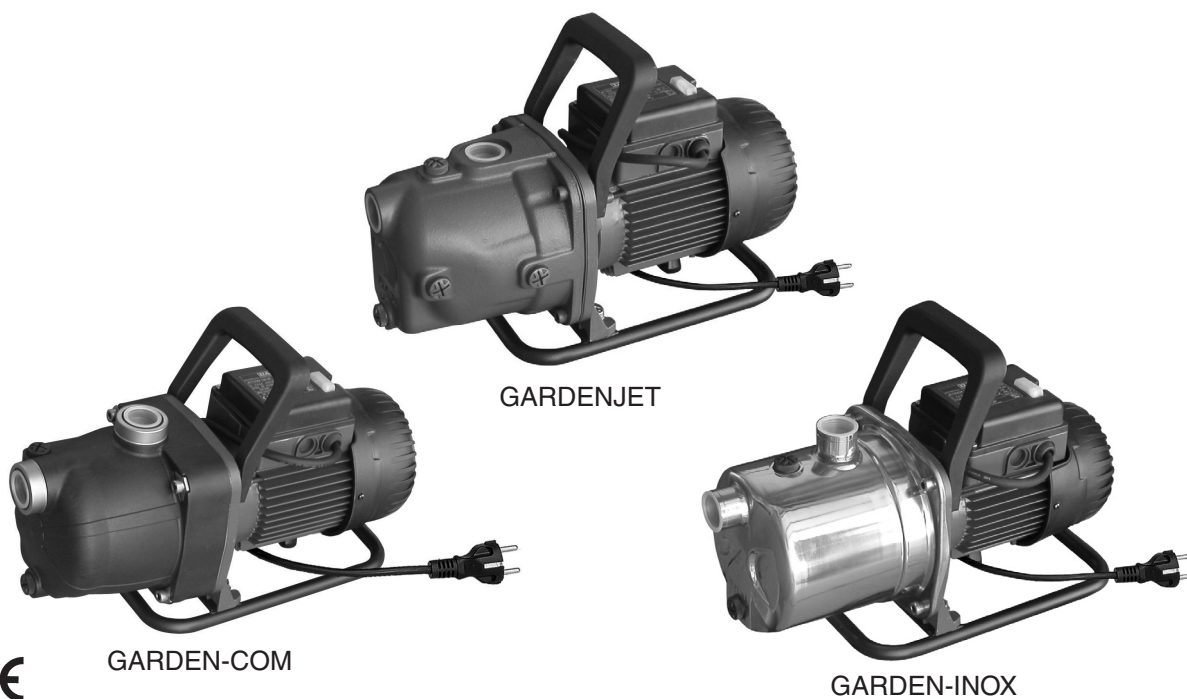

GENERAL DATA

Applications

Portable self-priming centrifugal electropump for gardening, vegetable gardens, washing and hobbies. Equipped with a handle for easy transport and 2-metre power cable type H07 RN-F complete with plug and switch. Compact and easy to install, self-priming so that it can take up water from tanks, wells or streams, tolerating air bubbles and water with small particles of sand.

Constructional features of the pump

Gardenjet: Cast iron pump body and die-cast aluminium motor support.
Garden-com: Technopolymer pump body and die-cast aluminium motor support.
Garden-inox: Stainless steel pump body.
Die-cast aluminium motor support.

Technopolymer impeller, diffuser and Venturi tube.

Stainless steel seal disc and pressure discs.

Carbon/ceramic mechanical seal.

Constructional features of the motor

Induction motor, closed and cooled with external ventilation.

Rotor mounted on oversized greased sealed-for-life ball bearings to ensure silent running and long life.

Built-in thermal and current overload protection and a capacitor permanently in circuit.

Manufactured according to CEI 2-3 and CEI 61-69 standards (EN 60335-2-41).

Motor protection: IP 44

Terminal box protection: IP 55

Insulation class: F

Standard voltage: single-phase 220-240 V/50 Hz

- Operating range: from 0.4 to 5.4 m³/h with head up to 54 metres
- Liquid quality requirements: clean, free from solids or abrasive substances, non viscous, non aggressive, non crystallized, chemically neutral, close to the characteristics of water.
- Liquid temperature range: from 0°C to +35°C for domestic use (EN 60335-2-41)
from 0°C to +40°C for other uses
- Maximum suction depth: 8 metres
- Maximum ambient temperature: +40°C
- Maximum operating pressure: 8 bar (800 kPa)
6 bar (600 kPa) only for technopolymer models (JETCOM)
- Installation: fixed or portable in a horizontal position
- Special executions on request: other voltages and/or frequencies

GARDENJET - TECHNICAL DATA

N.	PARTS*	MATERIALS
1	PUMP BODY	CAST IRON 200 UNI ISO 185
3	SUPPORT	DIE-CAST ALUMINIUM
4	IMPELLER	TECHNOPOLYMER A
7	SHAFT WITH ROTOR	STAINLESS STEEL AISI 416 X12 CrS13 - UNI 6900/71
16	MECHANICAL SEAL	CARBON/CERAMIC
28	OR GASKET	NBR RUBBER
160	NOZZLE-VENTURI DIFFUSER ASSEMBLY	TECHNOPOLYMER A

* In contact with the liquid.

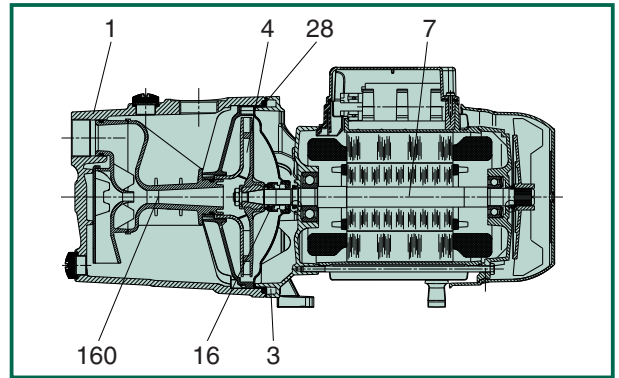

GARDEN-INOX - TECHNICAL DATA

N.	PARTS*	MATERIALS
1	PUMP BODY	STAINLESS STEEL AISI 304 X5 CRNi 1810 - UNI 6900/71
3	SUPPORT	DIE-CAST ALUMINIUM
4	IMPELLER	TECHNOPOLYMER A
7	SHAFT WITH ROTOR	STAINLESS STEEL AISI 303 X10 CrNiS 1809 - UNI 6900/71
16	MECHANICAL SEAL	CARBON/CERAMIC
28	OR GASKET	NBR RUBBER
36	SEAL COVER	STAINLESS STEEL AISI 304 X5 CRNi 1810 - UNI 6900/71
160	NOZZLE-VENTURI DIFFUSER ASSEMBLY	TECHNOPOLYMER A

* In contact with the liquid.

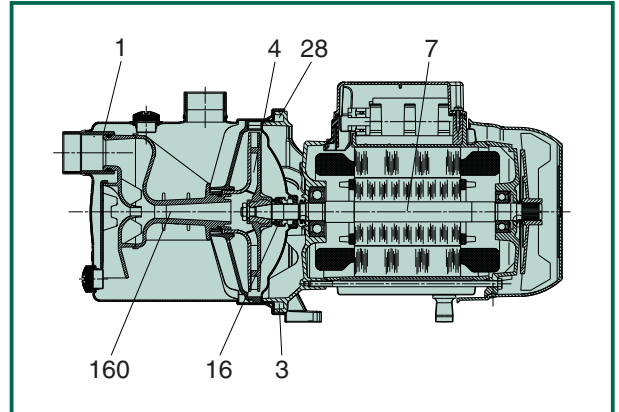

GARDEN-COM - TECHNICAL DATA

N.	PARTS*	MATERIALS
1	PUMP BODY	TECHNOPOLYMER A
3	SUPPORT	DIE-CAST ALUMINIUM
4	IMPELLER	TECHNOPOLYMER A
7	SHAFT WITH ROTOR	STAINLESS STEEL AISI 416 X12 CrS13 - UNI 6900/71
16	MECHANICAL SEAL	CARBON/CERAMIC
28	OR GASKET	NBR RUBBER
36	SEAL COVER	STAINLESS STEEL AISI 304 X5 CRNi 1810 - UNI 6900/71
160	NOZZLE-VENTURI DIFFUSER ASSEMBLY	TECHNOPOLYMER A

* In contact with the liquid.

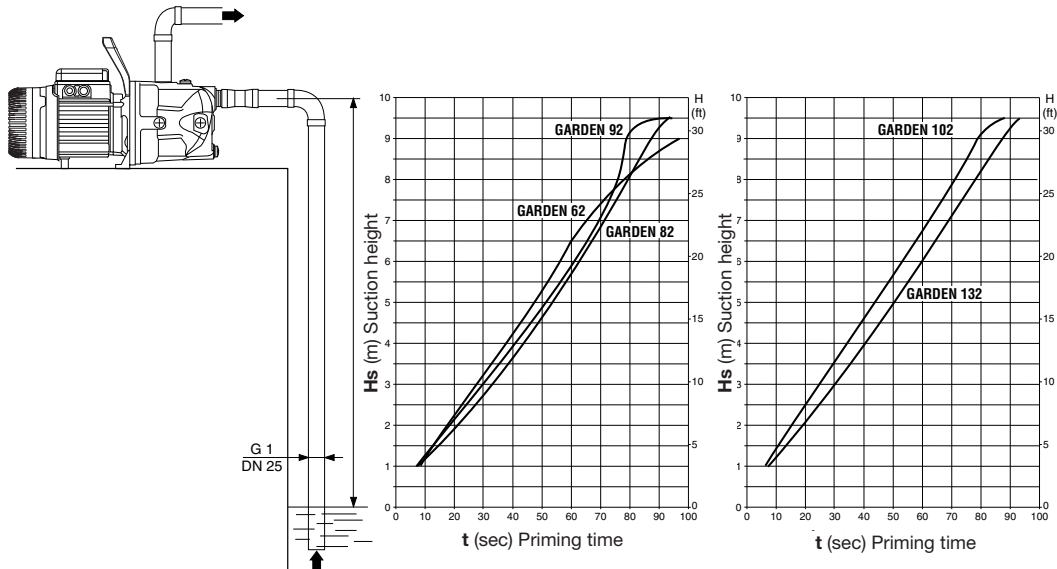
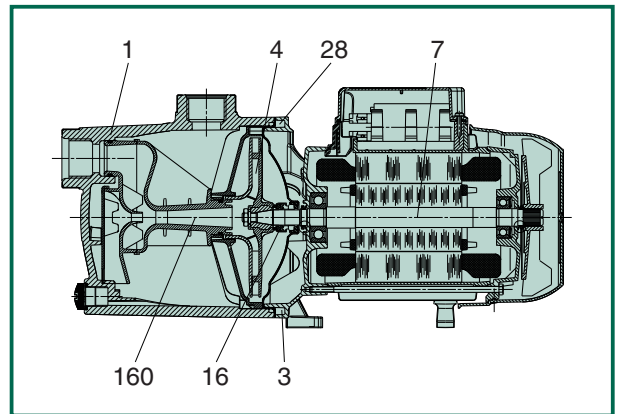

The performance curves are based on the kinematic viscosity values = 1 mm²/s and density equal to 1000 Kg/m³. Curve tolerance according to ISO 9906.
 Liquid temperature range: from 0 °C to +35°C
 Maximum ambient temperature: +40°C

GARDENJET

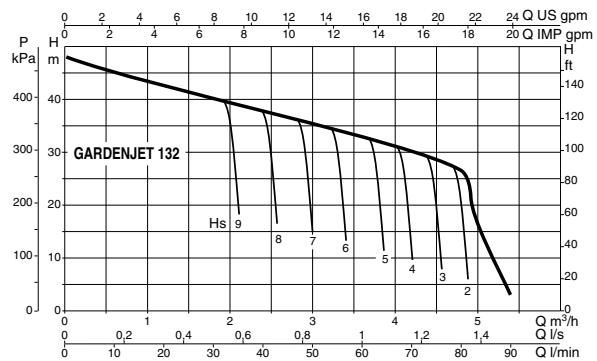
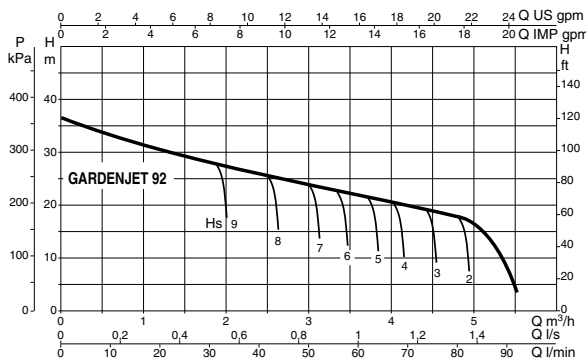
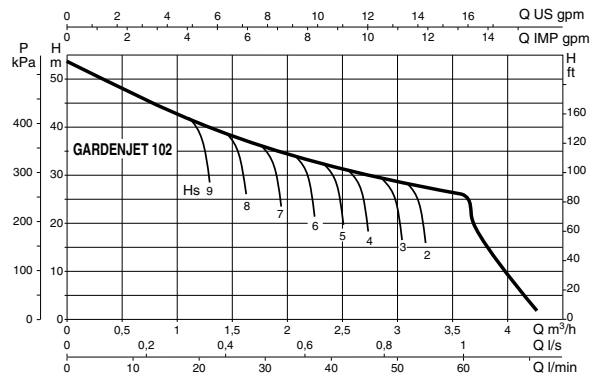
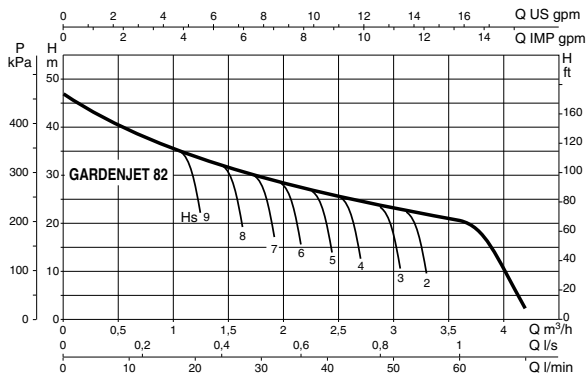
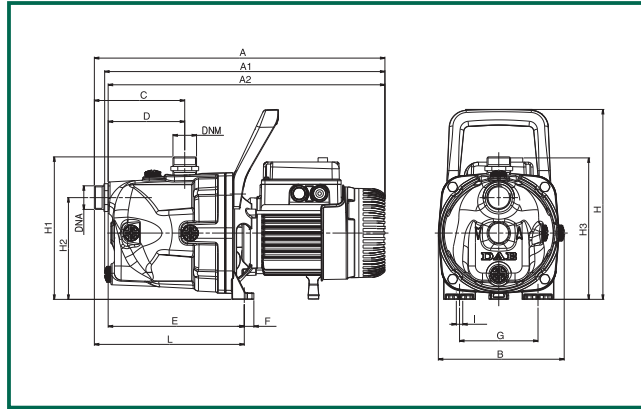

MODEL	A	A1	A2	B	C	D	E	F	G	H	H1	H2	H3	H4	I	L	DNA	DNM	PACKING DIMENSIONS			VOLUME	WEIGHT
																			L/A	L/B	H	m ³	Kg
GARDENJET 82 M	410	395	390	178	127	108	192	14	111	268	201	144	199	-	9	212	1" G	1" G	470	240	240	0,027	11,2
GARDENJET 102 M	429	414	409	178	127	108	192	14	111	268	200	144	209	-	9	212	1" G	1" G	470	240	240	0,027	13,0
GARDENJET 92 M	410	395	390	178	127	108	192	14	111	268	201	144	199	-	9	212	1" G	1" G	470	240	240	0,027	12,2
GARDENJET 132 M	429	414	409	178	127	180	192	14	111	268	200	144	209	-	9	212	1" G	1" G	470	240	240	0,027	14,0

MODEL	ELECTRICAL DATA							HYDRAULIC DATA (n ≈ 2850 1/min)															
	VOLTAGE 50 Hz	P1 MAX kW	P2 NOMINAL		In A	CAPACITOR		Q															
			kW	HP		μF	Vc	m³/h	0	0,6	1,2	1,8	2,4	3	3,6	4,2	4,8						
GARDENJET 82 M	1x220-240 V ~	0,85	0,6	0,8	3,8	12,5	450	47	40	34	30	26,2	23,5	20,3									
GARDENJET 102 M	1x220-240 V ~	1,13	0,75	1	5,1	16	450	53,8	47	41	36,3	32,4	28,8	25,8									
GARDENJET 92 M	1x220-240 V ~	0,94	0,75	1	4,2	14	450	36,2	33,5	31	28,4	26	24	21,8	19,6	17,5							
GARDENJET 132 M	1x220-240 V ~	1,49	1	1,36	6,6	25	450	48	45,6	42,8	40	37,6	35	32,5	30	27							

The performance curves are based on the kinematic viscosity values = 1 mm²/s and density equal to 1000 Kg/m³. Curve tolerance according to ISO 9906.
 Liquid temperature range: from 0 °C to +35°C
 Maximum ambient temperature: +40°C

GARDEN-INOX

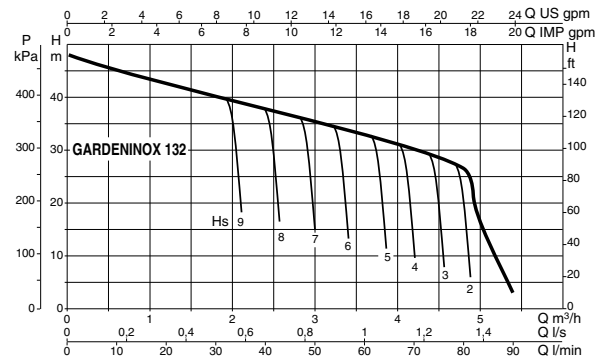
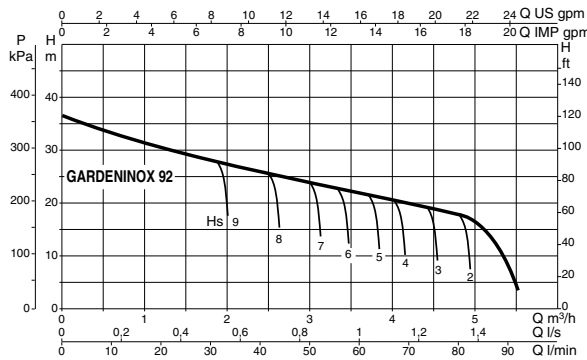
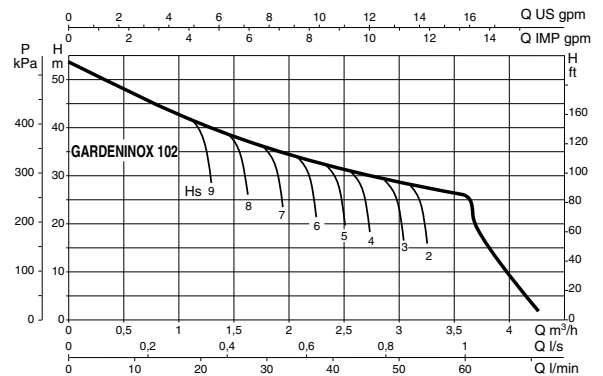
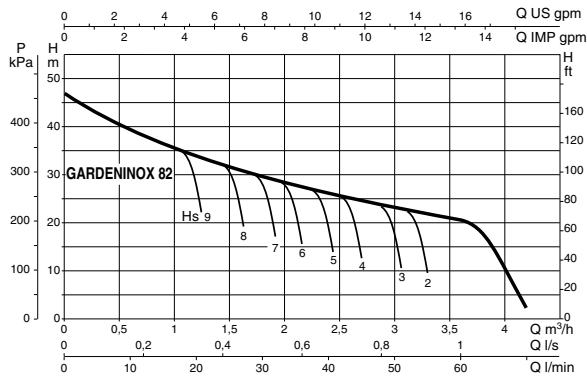
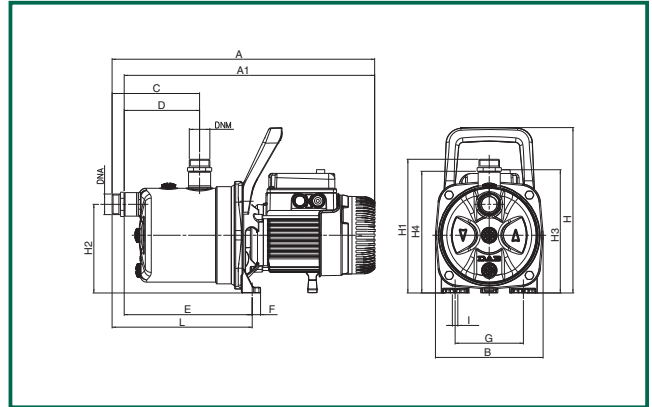

MODEL	A	A1	A2	B	C	D	E	F	G	H	H1	H2	H3	H4	I	L	DNA	DNM	PACKING DIMENSIONS			VOLUME m ³	WEIGHT Kg
	L/A	L/B	H																				
GARDEN-INOX 82 M	424	406	—	174	142	122	207	14	111	268	216	144	199	197	9	227	1" G	1" G	470	240	240	0,027	8,3
GARDEN-INOX 102 M	444	424	—	174	142	122	207	14	111	268	216	144	209	197	9	227	1" G	1" G	470	240	240	0,027	10,1
GARDEN-INOX 92 M	425	406	—	174	142	122	207	14	111	268	216	144	199	197	9	227	1" G	1" G	470	240	240	0,027	9,3
GARDEN-INOX 132 M	444	424	—	174	142	122	207	14	111	268	216	144	209	197	9	227	1" G	1" G	470	240	240	0,027	11,1

MODEL	ELECTRICAL DATA					HYDRAULIC DATA (n ≈ 2850 1/min)																	
	VOLTAGE 50 Hz	P1 MAX kW	P2 NOMINAL		In A	CAPACITOR μF Vc	Q																
			kW	HP			m³/h	0	0,6	1,2	1,8	2,4	3	3,6	4,2	4,8							
GARDEN-INOX 82 M	1x220-240 V ~	0,85	0,6	0,8	3,8	12,5	450	47	40	34	30	26,2	23,5	20,3									
GARDEN-INOX 102 M	1x220-240 V ~	1,13	0,75	1	5,1	16	450	53,8	47	41	36,3	32,4	28,8	25,8									
GARDEN-INOX 92 M	1x220-240 V ~	0,94	0,75	1	4,2	14	450	36,2	33,5	31	28,4	26	24	21,8	19,6	17,5							
GARDEN-INOX 132 M	1x220-240 V ~	1,49	1	1,36	6,6	25	450	48	45,6	42,8	40	37,6	35	32,5	30	27							

The performance curves are based on the kinematic viscosity values = 1 mm²/s and density equal to 1000 Kg/m³. Curve tolerance according to ISO 9906.
 Liquid temperature range: from 0 °C to +35°C
 Maximum ambient temperature: +40°C

GARDEN-COM

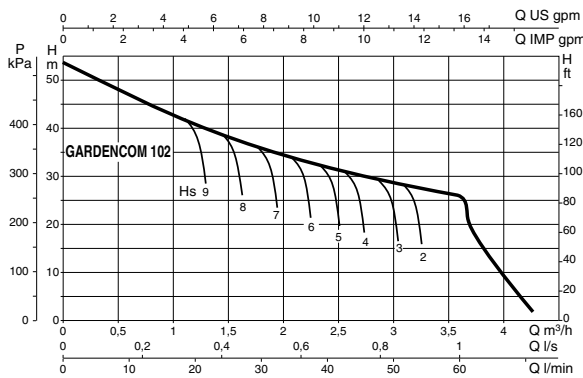
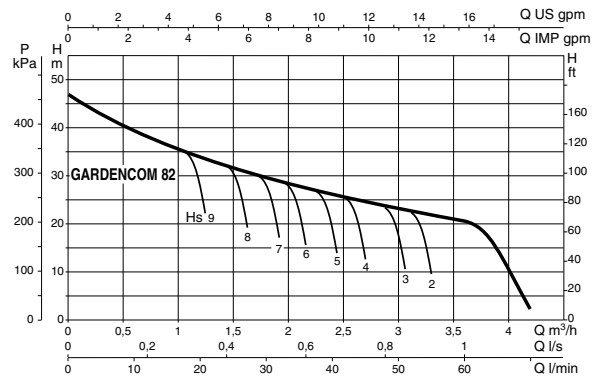
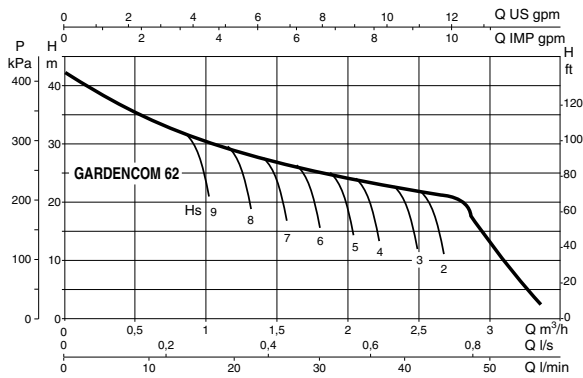
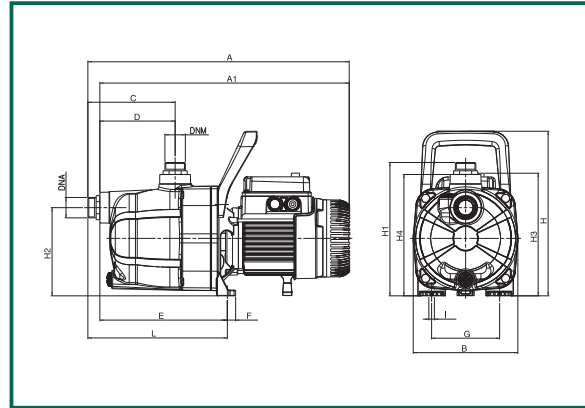

MODEL	A	A1	A2	B	C	D	E	F	G	H	H1	H2	H3	H4	I	L	DNA	DNM	PACKING DIMENSIONS			VOLUME m ³	WEIGHT Kg
																			L/A	L/B	H		
GARDEN-COM 62 M	425	406	-	170	142	122	208	14	111	268	217	144	199	198	9	227	1" G	1" G	470	240	240	0,027	8,0
GARDEN-COM 82 M	425	406	-	170	142	122	208	14	111	268	217	144	199	198	9	227	1" G	1" G	470	240	240	0,027	8,2
GARDEN-COM 102 M	444	425	-	170	142	122	208	14	111	268	217	144	209	203	9	227	1" G	1" G	470	240	240	0,027	10,0

MODEL	ELECTRICAL DATA							HYDRAULIC DATA (n ≈ 2850 1/min)															
	VOLTAGE 50 Hz	P1 MAX kW	P2 NOMINAL		In A	CAPACITOR		Q															
			kW	HP		μF	Vc	m³/h	0	0,6	1,2	1,8	2,4	3	3,6	4,2	4,8						
GARDEN-COM 62 M	1x220-240 V ~	0,72	0,44	0,6	3,12	12,5	450	H (m)	42,7	35	29,2	25,6	22,9	13									
GARDEN-COM 82 M	1x220-240 V ~	0,85	0,6	0,8	3,8	12,5	450		47	40	34	30	26,2	23,5	20,3								
GARDEN-COM 102 M	1x220-240 V ~	1,13	0,75	1	5,1	16	450		53,8	47	41	36,3	32,4	28,8	25,8								

DP

FOR DEEP SUCTION



DP 82-102

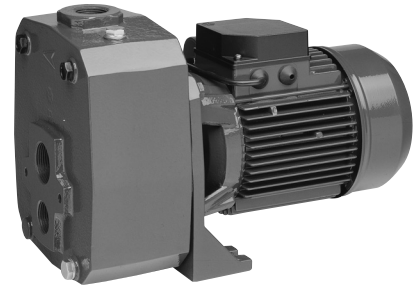

DP 151-251

GENERAL DATA

Applications

Self-priming centrifugal pump for suction up to 27 metres, reached by means of an ejector to be inserted in wells with a diameter of 4" or over. For use in supplying water to farmhouses and in small-scale agriculture.

Constructional features of the pump

Pump: Cast iron pump body and motor support. Technopolymer impeller and diffuser. Stainless steel pressure disc. Carbon/ceramic mechanical seal.

Ejector: Cast iron body. Technopolymer A Venturi tube and brass nozzle.
The ejector is available in three models (E20 - E25 - E30) to be chosen according to performance requirements.

Constructional features of the motor

Induction motor, closed and cooled with external ventilation.

Rotor mounted on oversized greased sealed-for-life ball bearings.

Built-in thermal and current overload protection and a capacitor permanently in circuit in the single-phase version.

Three-phase motors should be protected with a suitable overload protection complying with the regulations in force.

Manufactured according to CEI 61-69 standards (EN 60335-2-41).

Motor protection: IP 44

Terminal box protection: IP 55

Insulation class: F

Standard voltage: single-phase 220-240 V/50 Hz
 three-phase 230-400 V/50 Hz

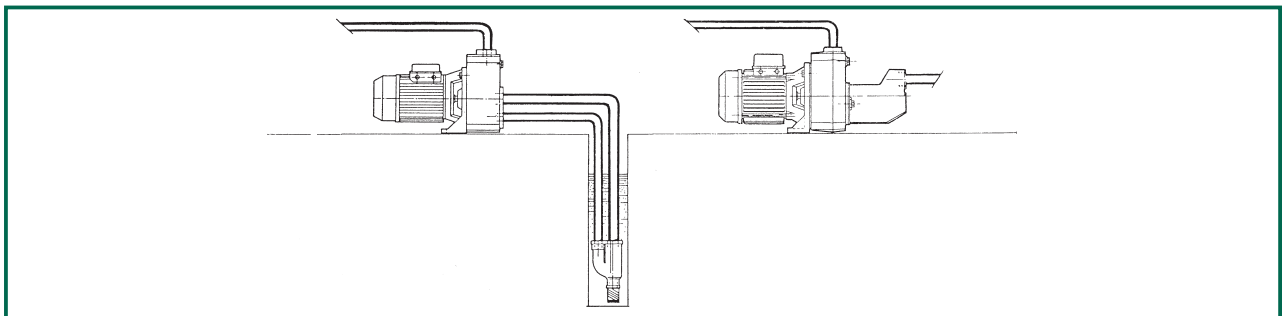

TECHNICAL DATA

N.	PARTS*	MATERIALS
1	PUMP BODY	CAST IRON 200 UNI ISO 185
2	EJECTOR BODY	CAST IRON 200 UNI ISO 185
3	SUPPORT	CAST IRON 200 UNI ISO 185
4	IMPELLER	TECHNOPOLYMER
6	DIFFUSER	TECHNOPOLYMER
7	SHAFT WITH ROTOR	STAINLESS STEEL AISI 416 X12 CrS13 UNI 6900/71 (DP 82 - DP 102) STAINLESS STEEL AISI 303 X10CrNiS 1809 UNI 6900/71 (DP 151 - DP 251)
8	VENTURI TUBE	TECHNOPOLYMER
9	NOZZLE	BRASS
16	MECHANICAL SEAL	CARBON/CERAMIC
28	OR GASKET	NBR RUBBER

* In contact with the liquid.

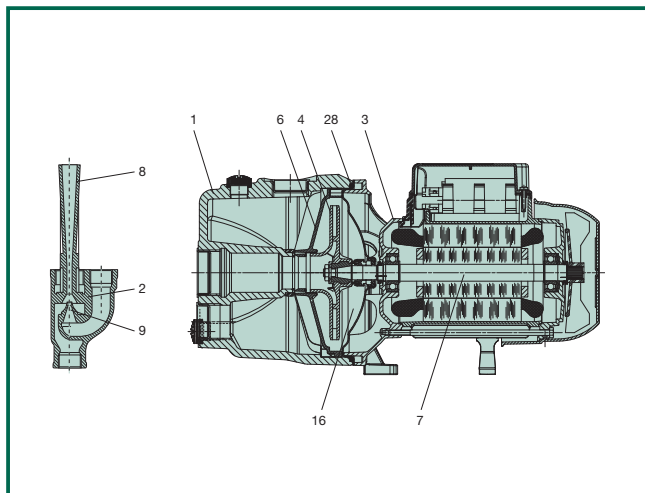

- Operating range: up to 4.3 m³/h.
- Liquid quality requirements: clean, free from solids or abrasive substances, non viscous, non aggressive, non crystallized, chemically neutral, close to the characteristics of water.
- Liquid temperature range: from 0°C to +35°C for domestic use (EN 60335-2-41)
from 0°C to +40°C for other uses
- Maximum ambient temperature: +40°C
- Maximum operating pressure: DP 82 - DP 102 6 bar (600 kPa)
DP 151 - DP 251 8 bar (800 kPa)
- Installation: fixed in a horizontal position
- Special executions on request: other voltages and/or frequencies

Liquid temperature range: from 0 °C to +35°C

Maximum ambient temperature: +40°C

DP 82 - DP 102

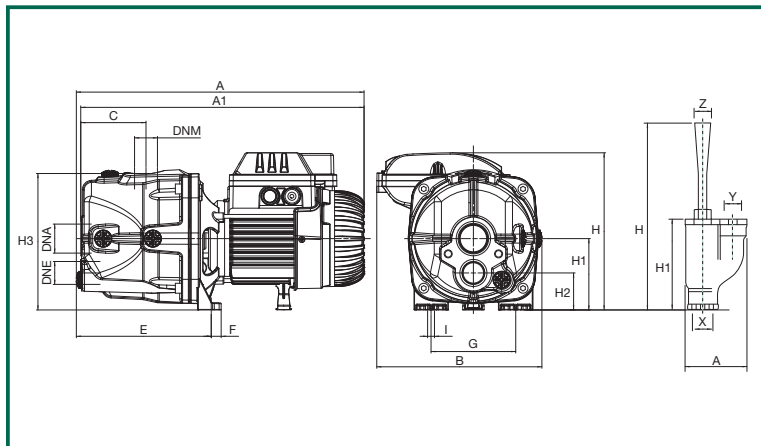

HYDRAULIC DATA (n ≈ 2800 1/min)									
PUMP TYPE	EJECTOR TYPE	SUCTION DEPTH	Delivery pressure in bar						
			1,5	2	2,5	3	3,5	4	
DP 82	E 25	9	1813	1080	446	33	-	-	-
		12	1426	720	225	-	-	-	-
		15	900	326	-	-	-	-	-
	E 30	9	1753	1286	812	524	261	12	-
		12	1345	965	608	329	162	0	-
		15	1166	761	452	228	45	-	-
DP 102	E 25	9	2386	1756	1097	515	126	-	-
		12	1930	1190	536	87	-	-	-
		15	1459	773	252	-	-	-	-
	E 30	12	-	1240	872	566	329	156	-
		15	-	1028	701	449	255	96	-
		18	-	785	527	302	150	15	-
		21	-	635	374	180	39	-	

MODEL	A	A1	B	C	E	F	G	H	H1	H2	H3	I	DNA	DNM	DNE	EJECTOR					PACKING DIMENSIONS			VOL. m ³	WEIGHT Kg	
																A	H	H1	x	y	z	L/A	L/B			H
DP 82	377	371	175	86	177	13	111	194	94	49	179	9	1 1/4" G	1" G	1" G	97	295	143	1" G	1" G	1 1/4" G	480	240	240	0,03	10,7
DP 102	398	392	175	86	177	13	111	203	94	49	179	9	1 1/4" G	1" G	1" G	97	295	143	1" G	1" G	1 1/4" G	480	240	240	0,03	13

MODEL	ELECTRICAL DATA						
	VOLTAGE 50 Hz	P1 MAX kW	P2 NOMINAL kW	HP	In A	CAPACITOR μF	Vc
DP 82 M	1x220-240 V ~	0,73	0,6	0,8	3,4	12,5	450
DP 82 T	3x230-400 V ~	0,73	0,6	0,8	2,6-1,5	-	-

MODEL	ELECTRICAL DATA						
	VOLTAGE 50 Hz	P1 MAX kW	P2 NOMINAL kW	HP	In A	CAPACITOR μF	Vc
DP 102 M	1x220-240 V ~	0,79	0,75	1	3,8	16	450
DP 102 T	3x230-400 V ~	0,64	0,75	1	2,6-1,5	-	-

Liquid temperature range: from 0 °C to +35°C

Maximum ambient temperature: +40°C

DP 151 - 251

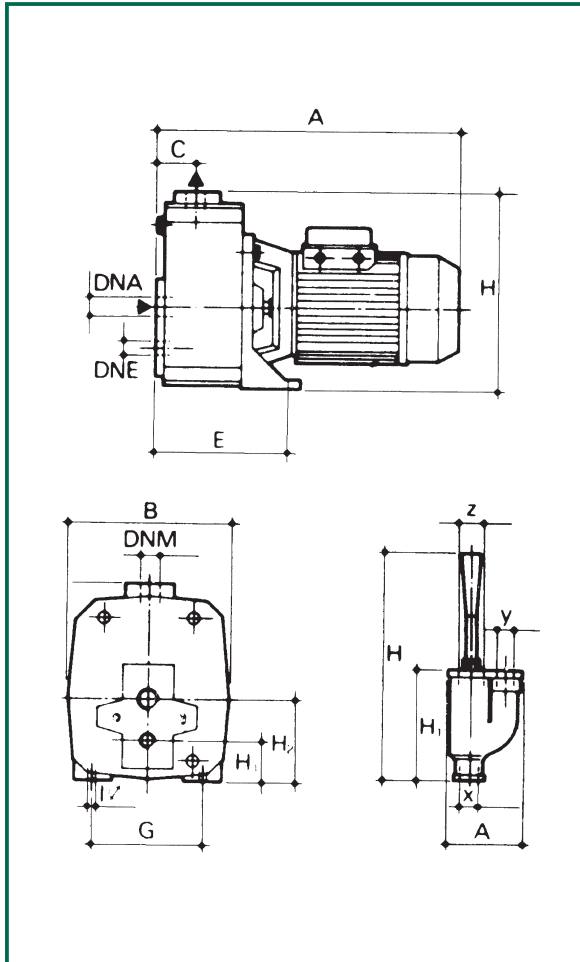

HYDRAULIC DATA (n ≈ 2800 1/min)											
PUMP TYPE	EJECTOR TYPE	SUCTION DEPTH	Delivery pressure in bar								
			3	3,5	4	4,5	5	5,5	6	6,5	7
Flow table in l/h											
DP 151	E 20	9	3470	2890	2220	1500	750	-	-	-	-
		12	3110	2510	1850	1100	300	-	-	-	-
		15	2710	2100	1380	640	-	-	-	-	-
		18	2360	1700	950	-	-	-	-	-	-
	E 25	15	2800	2330	1830	1350	900	520	-	-	-
		18	2530	2050	1550	1090	680	300	-	-	-
		21	2280	1800	1300	860	470	-	-	-	-
	E 30	21	1820	1650	1410	1160	910	700	520	-	-
		24	1680	1520	1260	1020	780	580	420	-	-
27		1550	1360	1110	880	680	490	330	-	-	
DP 251	E 20	9	4300	3600	2900	2180	1400	640	-	-	-
		12	3750	3140	2540	1700	940	-	-	-	-
		15	-	2780	2040	1300	500	-	-	-	-
		18	-	2340	1610	820	-	-	-	-	-
E 25	15	-	2920	2400	1900	1400	950	570	-	-	
	18	-	2600	2110	1620	1150	720	360	-	-	
	21	-	2350	1850	1350	900	510	-	-	-	
	24	-	2050	1550	1080	660	300	-	-	-	
E 30	21	-	-	1710	1480	1220	980	770	590	420	
	24	-	-	1580	1330	1080	850	670	490	330	
	27	-	-	1440	1200	950	750	560	400	250	

MODEL	A	B	C	E	G	I Ø	H	H1	H2	DNA	DNM	DNE	EJECTOR						PACKING DIMENSIONS			VOL. m³	WEIGHT Kg
													A	H	H1	x	y	z	L/A	L/B	H		
DP 151	388	210	50	197	145	11	255	53	108	1 1/4" G	1" G	1" G	97	295	143	1" G	1" G	1 1/4" G	427	246	307	0,3	28,5
DP 251 M	462	210	50	197	145	11	255	53	108	1 1/4" G	1" G	1" G	97	295	143	1" G	1" G	1 1/4" G	522	246	307	0,4	32,5
DP 251 T	388	210	50	197	145	11	255	53	108	1 1/4" G	1" G	1" G	97	295	143	1" G	1" G	1 1/4" G	427	246	307	0,3	27,9

MODEL	ELECTRICAL DATA					
	VOLTAGE 50 Hz	P1 MAX kW	P2 NOMINAL kW	HP	In A	CAPACITOR µF Vc
DP 151 M	1x220-240 V ~	1,56	1,1	1,5	7	31,5 450
DP 151 T	3x230-400 V ~	1,45	1,1	1,5	4,7-2,7	- -

MODEL	ELECTRICAL DATA					
	VOLTAGE 50 Hz	P1 MAX kW	P2 NOMINAL kW	HP	In A	CAPACITOR µF Vc
DP 251 M	1x220-240 V ~	1,84	1,85	2,5	8,3	40 450
DP 251 T	3x230-400 V ~	1,78	1,85	2,5	5,6-3,2	- -

EUROSWIM



TECHNICAL DATA

Applications

High efficiency self-priming centrifugal pumps with built-in large capacity prefilter. **Completely watertight motor**. Extremely **quiet running** and **great reliability**, developed for water circulation and filtration in domestic and residential swimming pools. Suitable also for special applications that call for handling of aggressive liquids, in fish farms, agriculture and industry.

Pump construction features

Pump body in fibreglass reinforced technopolymer. Strainer cover in clear antioxidant polycarbonate to guarantee constant visibility through time. Nylon strainer. Impeller in fibreglass-reinforced technopolymer developed to ensure total coverage and isolation of the motor shaft from the pumped liquid. Diffuser in reinforced technopolymer. Mechanical seal in carbon / alumina / NBR / AISI 316. Pump body O-rings in NBR, threaded fasteners and reinforcing rings in AISI 316. Butterfly filler and drain plugs that can be removed and refitted without tools.

Motor construction characteristics

Asynchronous continuous duty 2-pole motor (S1) with generous range of power ratings from 0.5 HP to 3 HP, single phase and three-phase (see technical specifications).

Motor casing in die cast aluminium with electrophoresis surface treatment to prevent oxidation even in aggressive environmental conditions. Baseplate supplied as standard with rubber mounts to reduce vibration transmission.

Single phase version with integral thermal and overcurrent protection and permanent split capacitor (PSC), assembled inside the terminal box for all versions.

Motor and terminal box protection rating: IP55

Insulation class: F

Ball bearings: water-proof, sealed, resistant to water and humidity.

Motor construction to EN 60335-2-41 standards

Standard voltage: Single phase 220-240V 50Hz

Three-phase 230/400V 50Hz

TECHNICAL DATA

Operating range: up to 42 m³/h with pressure head of up to 22 m
 Pumped liquid: clean water or slightly contaminated with suspended solid debris, highly aggressive water with high percentage of chlorine/bromine and PHMB (Polyhexamethylene biguanide) or water treated with the chlorine electrolysis process.
 long fibre;
 PH range: 6.5 – 8.4
 Liquid temperature range: up to 60°C
 Maximum ambient temperature : 50°C
 Maximum working pressure: 2.5 Bar
 Nominal working pressure: 0.8 - 1.2 bar (ideally 1 bar)
 Installation: fixed or portable in horizontal position
 Special executions on request: other voltages and/or frequencies.
 Fittings on request: kit 2"/50 - 63 (two fittings + O-ring - see "Accessories")
 Reference standard: IEC – 60364

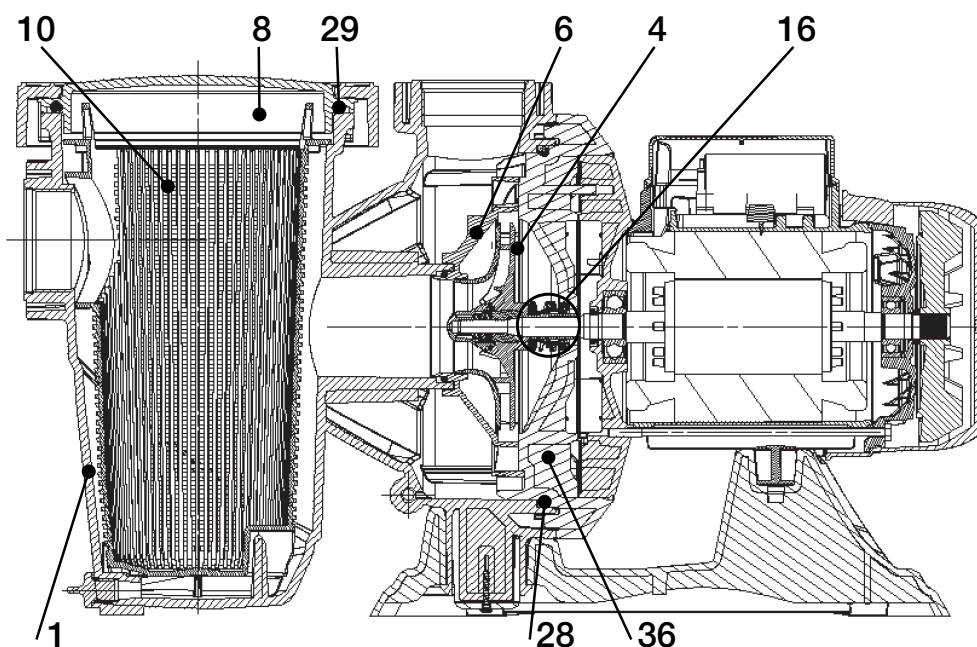

N	PART (*)	MATERIAL
1	PUMP CASING	REINFORCED TECHNOPYLIMER
4	IMPELLER	REINFORCED TECHNOPYLIMER
6	DIFFUSER	REINFORCED TECHNOPYLIMER
8	STRAINER COVER	POLYCARBONATE
10	FILTER	TECNOPYLIMER
16	MECHANICAL SEAL	CARBON / ALUMINA / NBR / AISI 316
28	O-RING	NBR
29	O-RING	NBR
36	SEAL CARRIER DISC	REINFORCED AND STABILISED TECHNOPYLIMER

*TO CONTACT WITH THE LIQUID

The performance curves are based on kinematic viscosity values = 1 mm²/s and density equivalent to 1000 kg/m³. Tolerance of curves to ISO 9906.
 Liquid temperature range: from 0°C to 60°C
 Maximum ambient temperature: +50°C

EUROSWIM 50

HYDRAULIC DATA

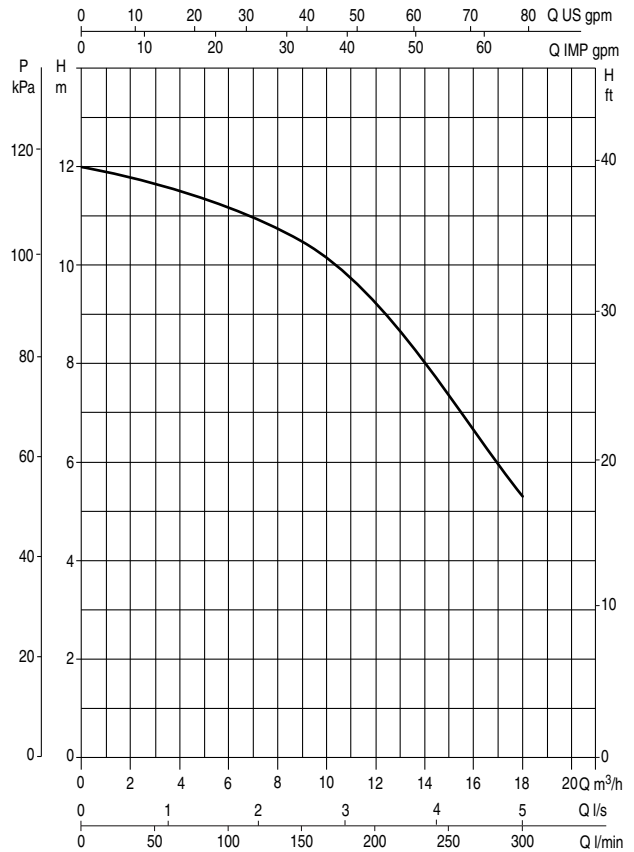
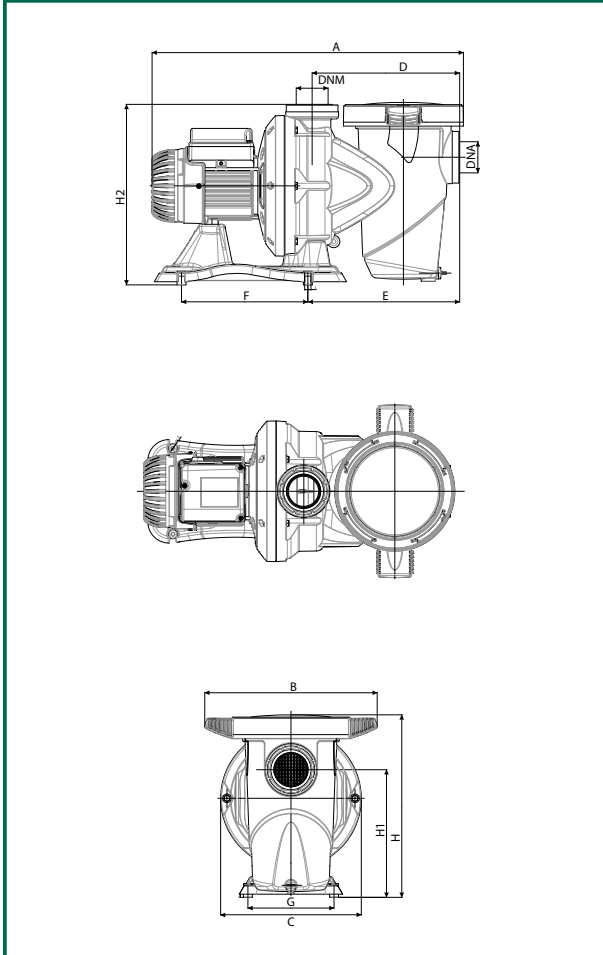

DIMENSIONS AND WEIGHTS

MODEL	A	B	C	D	E	F	G	H	H1	H2	I	L	DNA	DNM	NO. PIECES PALLET	DIMENSION PACKING			VOLUME m ³	GROSS WEIGHT Kg
																L/A	L/B	H		
EUROSWIM 50 M	542	300	245	257	265	220	150	317	222	314	11	6,5	G2"	G2"	8	600	360	400	0,09	11,1

ELECTRICAL DATA

MODEL	ELECTRICAL DATA								NOISE LEVEL dB (A)	Q m ³ /h l/min	HYDRAULIC DATA					
	SUPPLY VOLTAGE 50 Hz	P1 MAX W	P2 NOMINAL		In A	CAPACITOR		0			3	6	9	12	18	
			kW	HP		µF	Vc									0
EUROSWIM 50 M	1x220-240 V ~	900	0,33	0,5	4,2	16	450	53	H (m)	12,0	11,7	11,2	10,5	9,3	5,3	

The performance curves are based on kinematic viscosity values = 1 mm²/s and density equivalent to 1000 kg/m³. Tolerance of curves to ISO 9906.
 Liquid temperature range: from 0°C to 60°C
 Maximum ambient temperature: +50°C

EUROSWIM 75

HYDRAULIC DATA

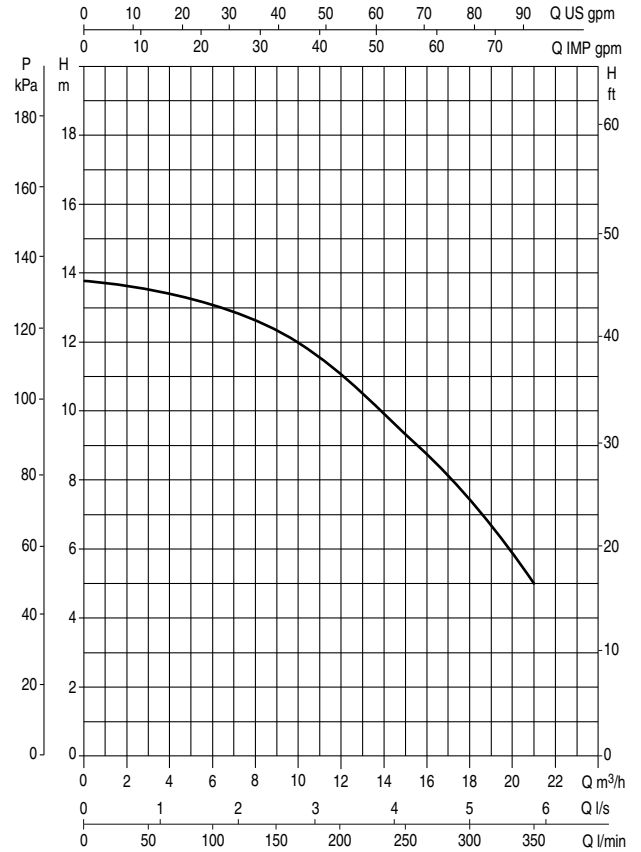
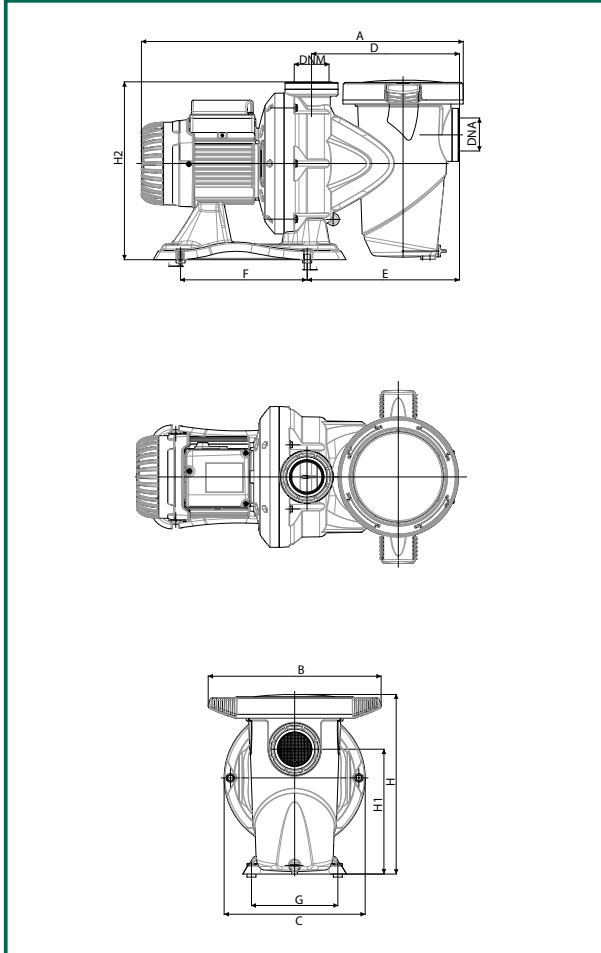

DIMENSIONS AND WEIGHTS

MODEL	A	B	C	D	E	F	G	H	H1	H2	I	L	DNA	DNM	NO. PIECES PALLET	DIMENSION PACKING			VOLUME m ³	GROSS WEIGHT Kg
	L/A	L/B	H																	
EUROSWIM 75 M	559	300	245	257	265	220	150	317	222	314	11	6,5	G2"	G2"	8	600	360	400	0,09	12,1
EUROSWIM 75 T	559	300	245	257	265	220	150	317	222	314	11	6,5	G2"	G2"	8	600	360	400	0,09	12,1

ELECTRICAL DATA

MODEL	ELECTRICAL DATA							NOISE LEVEL dB (A)	Q m ³ /h l/min	HYDRAULIC DATA						
	SUPPLY VOLTAGE 50 Hz	P1 MAX W	P2 NOMINAL		In A	CAPACITOR				H (m)						
			kW	HP		μF	Vc			0	3	6	9	12	18	21
EUROSWIM 75 M	1x220-240 V ~	1000	0,5	0,75	5	20	450	56	H	13,8	13,5	13,1	12,4	11,1	7,5	5
EUROSWIM 75 T	3x230-400 V ~	950	0,5	0,75	3,5 / 2	-	-	56	(m)	13,8	13,5	13,1	12,4	11,1	7,5	5

The performance curves are based on kinematic viscosity values = 1 mm²/s and density equivalent to 1000 kg/m³. Tolerance of curves to ISO 9906.
 Liquid temperature range: from 0°C to 60°C
 Maximum ambient temperature: +50°C

EUROSWIM 100

HYDRAULIC DATA

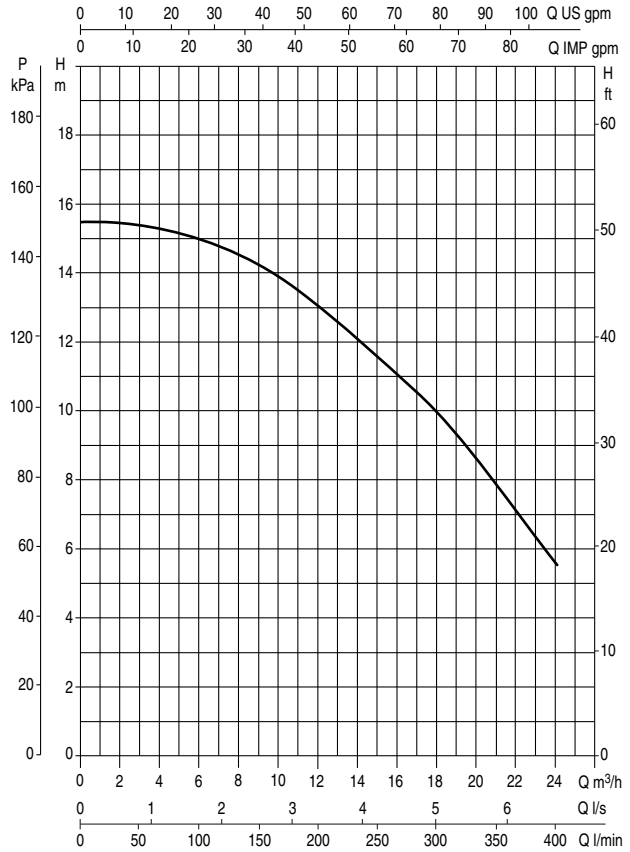
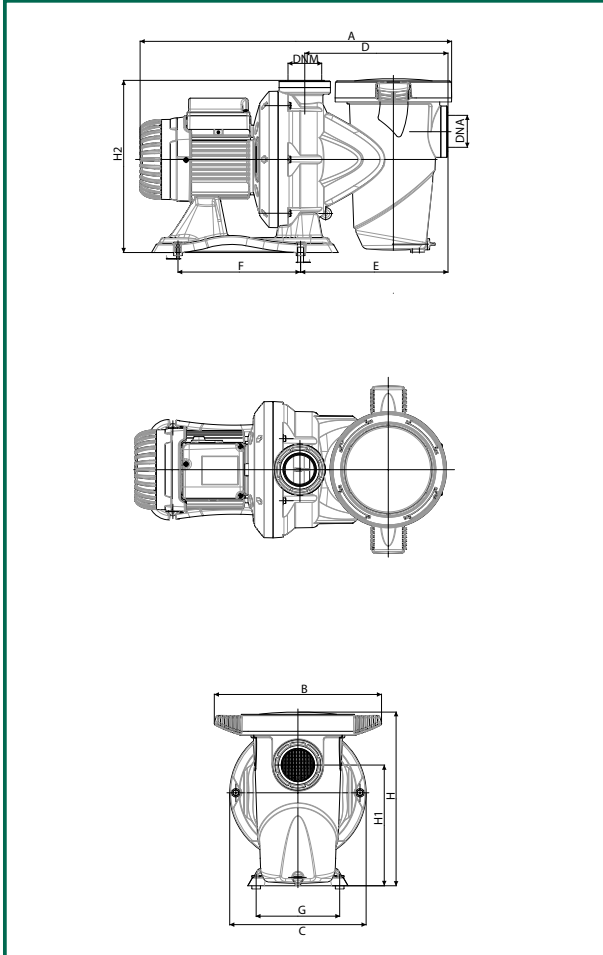

DIMENSIONS AND WEIGHTS

MODEL	A	B	C	D	E	F	G	H	H1	H2	I	L	DNA	DNM	NO. PIECES PALLET	DIMENSION PACKING			VOLUME m ³	GROSS WEIGHT Kg
																L/A	L/B	H		
EUROSWIM 100 M	559	300	245	257	265	220	150	317	222	314	11	6,5	G2"	G2"	8	600	360	400	0,09	13,8
EUROSWIM 100 T	559	300	245	257	265	220	150	317	222	314	11	6,5	G2"	G2"	8	600	360	400	0,09	13,8

ELECTRICAL DATA

MODEL	ELECTRICAL DATA								NOISE LEVEL dB (A)	Q m ³ /h l/min	HYDRAULIC DATA							
	SUPPLY VOLTAGE 50 Hz	P1 MAX W	P2		In A	CAPACITOR		Q			0	3	6	9	12	18	21	24
			NOMINAL kW	HP		μF	Vc				0	50	100	150	200	300	350	400
EUROSWIM 100 M	1x220-240 V ~	1300	0,75	1	6,3	25	450	57	H	15,4	15,4	15	14,2	13,1	10,0	7,8	5,6	
EUROSWIM 100 T	3x230-400 V ~	1200	0,75	1	4 / 2,4	-	-	57	H (m)	15,4	15,4	15	14,2	13,1	10,0	7,8	5,6	

ACCESSORIES

2" GAS / DN 50-63 CONNECTION FITTINGS KIT

Supplied complete with two items to be fitted on the suction and discharge ports to connect the pump to the system.

The connection with O-ring (towards the pump) is equipped with DN 50 and 63 coupling for greater installation flexibility.

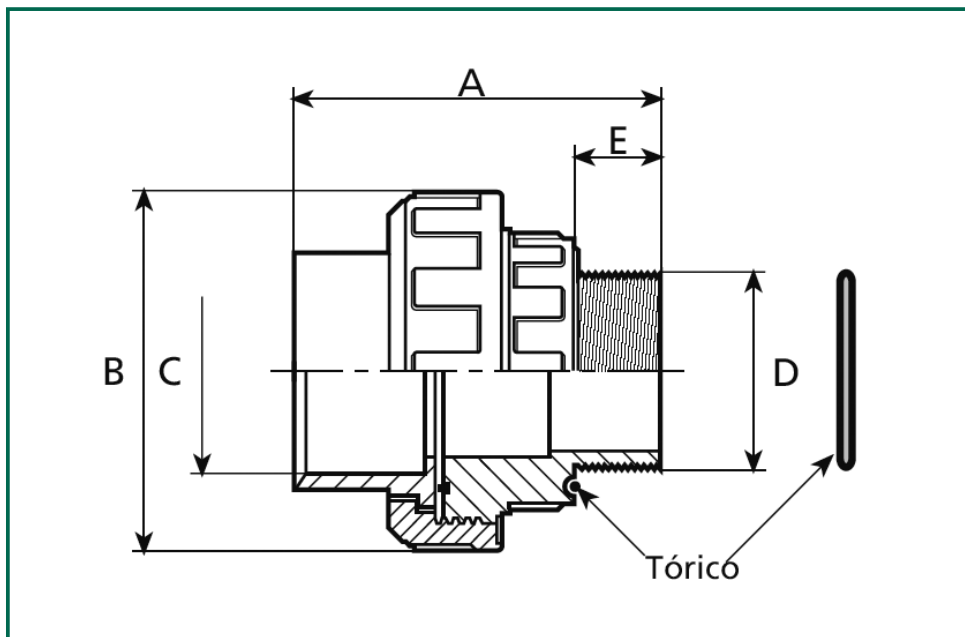

DIMENSIONS AND WEIGHTS

MODEL	A	B	C	D	E	GROSS WEIGHT Kg
2" UNION KIT	99	99	50/63	2"	20	0,7

JETCOM SP



GENERAL DATA

Applications

Self-priming centrifugal pump with excellent suction capacity even when there are air bubbles. Suitable for use with water containing small sand impurities. Particularly suitable for water supply in domestic installations: movimentation of aggressive water in general containing chlorine (water coming from swimming pools).

Pump construction characteristics

Pump body in technopolymer. Support, seal holder in AISI 316 STAINLESS STEEL. Mechanical seal in carbon/ceramic. Rotor shaft in AISI 316 STAINLESS STEEL. Impellers, diffuser, venturi tube and sand guard in technopolymer. Wear rings in stainless steel.

Motor construction characteristics

Continuous duty asynchronous motor.

Built-in motor overload cut out and a capacitor permanently on in the single-phase version.

Protection for the three-phase version is the responsibility of the user.

Motor protection level: IP 44

Terminal board protection level: IP 55

Insulation class: F

Standard voltage: single-phase 220/240V - 50 Hz - 2 poles
 three-phase 230/400V - 50 Hz - 2 poles

TECHNICAL DATA

N.	PARTS *	MATERIALS
1	PUMP BODY	TECHNOPOLYMER A
4	IMPELLER	TECHNOPOLYMER A
7	SHAFT WITH ROTOR	STAINLESS STEEL AISI 316
16	MECHANICAL SEAL	CARBON/CERAMIC
28	GASKET OR	NBR
36	SEAL HOLDER COVER	STAINLESS STEEL AISI 316
160	NOZZLE-VENTURI DIFFUSER ASSEMBLY	TECHNOPOLYMER A

* In contact with the liquid.

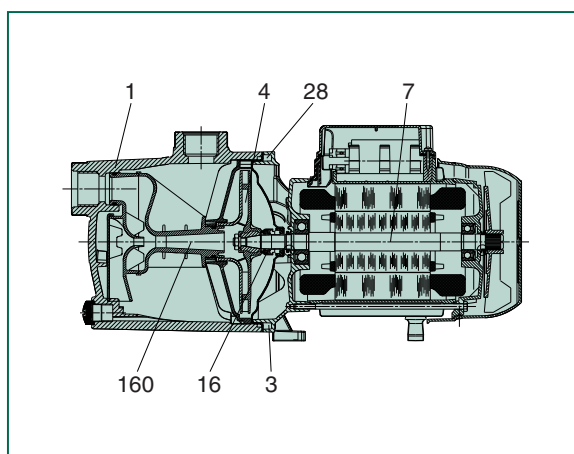

- Operating range: from 10 to 60 l/min. with head up to 53,8 m.
- Pumped liquid: clean, free from solids and abrasive substances, water coming from swimming pools (containing chlorine).
- Liquid temperature range: from 0°C to +35°C for domestic use (EN 60335-2-41)
from 0°C to +40°C for other uses.
- Maximum ambient temperature: +40°C
- Maximum operating pressure: 6 bar (600 kPa)
- Installation: fixed or portable in horizontal position

The performance curves are based on the kinematic viscosity values = 1 mm²/s and density equal to 1000 Kg/m³. Curve tolerance according to ISO 9906.
 Liquid temperature range: from 0 °C to +35°C
 Maximum ambient temperature: +40°C

JETCOM SP 102

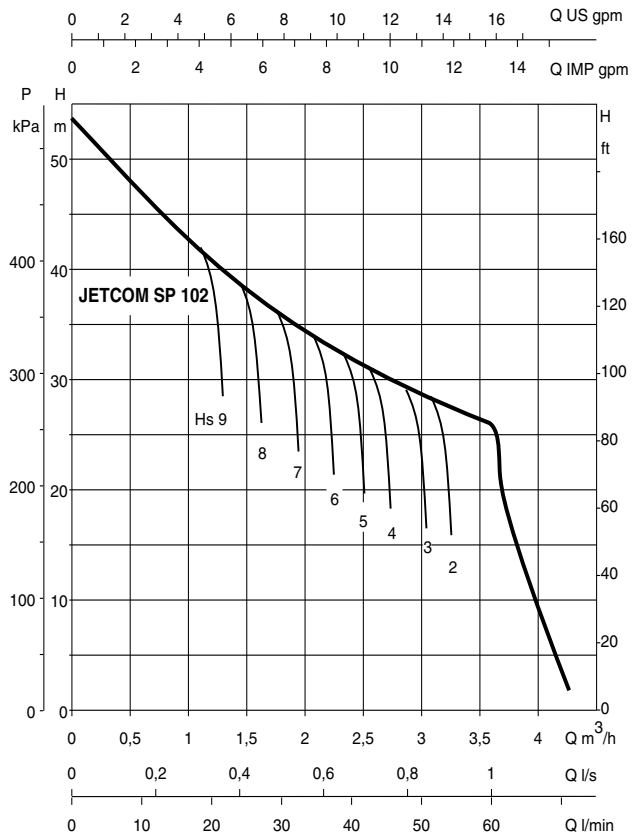
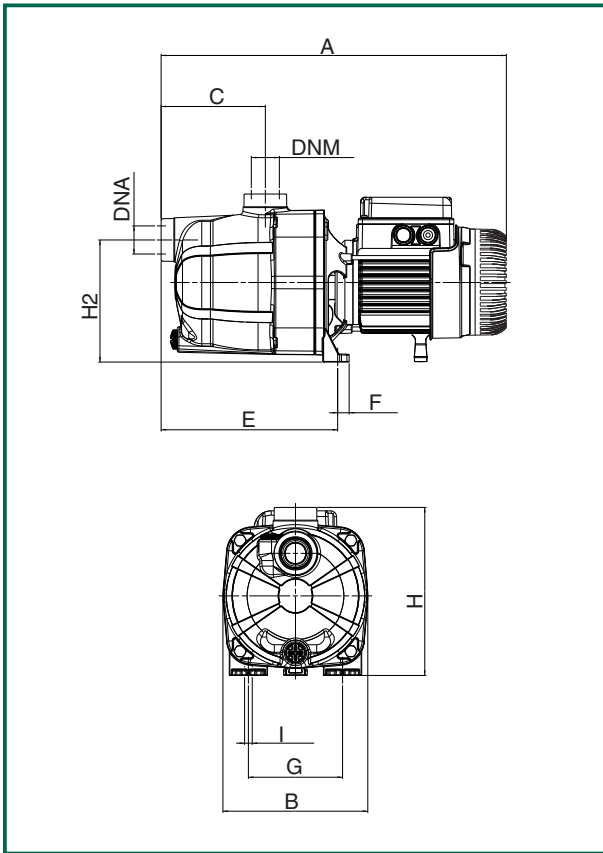

MODEL	A	B	C	E	F	G	I Ø	H	H2	DNA	DNM	PACKING DIMENSIONS			VOLUME m ³	WEIGHT Kg
												L/A	L/B	H		
JETCOM SP 102	425	170	122	208	14	111	9	203	144	1" G	1" G	470	240	240	0,027	9,5

MODEL	ELECTRICAL DATA						HYDRAULIC DATA (n = 2800 1/min)									
	VOLTAGE 50 Hz	P1 MAX kW	P2 NOMINAL		In A	CAPACITOR		Q								
			kW	HP		µF	Vc	m ³ /h	0	0,6	1,2	1,8	2,4	3	3,6	
JETCOM SP 102 M	1x220-240 V ~	1,13	0,75	1	5,1	16	450	0	10	20	30	40	50	60		
JETCOM SP 102 T	3x230-400 V ~	1,04	0,75	1	3,3-1,9	-	-	H (m)	53,8	47	41	36,3	32,4	28,8	25,8	

EUROCOM SP



GENERAL DATA Applications

Multistage horizontal centrifugal pump, featuring extremely silent running suitable for domestic use: movement of aggressive water in general containing chlorine (water coming from swimming pools).

Pump construction characteristics

Pump body in technopolymer. Motor support in die-cast aluminium, seal holder cover in AISI 316 STAINLESS steel. Mechanical seal in carbon/ceramic. Rotor shaft in AISI 316 STAINLESS STEEL. Impellers, diffuser bodies and diffusers in technopolymer. Wear rings in stainless steel.

Motor construction characteristics

Continuous duty asynchronous motor.

Built-in motor overload cut out and a capacitor permanently on in the single-phase version.

Protection for the three-phase version is the responsibility of the user.

Motor protection level: IP 44

Terminal board protection level: IP 55

Insulation class: F

Standard voltages:	Single-phase	220/240V - 50 Hz - 2 poles
	Three-phase	230/400V - 50 Hz - 2 poles

TECHNICAL DATA

N.	PARTS	MATERIALS
1	PUMP BODY	TECHNOPOLYMER
4	IMPELLER	TECHNOPOLYMER
6	DIFFUSER	TECHNOPOLYMER
7	SHAFT WITH ROTOR	STAINLESS STEEL AISI 316
16	MECHANICAL SEAL	CARBON/CERAMIC
28	GASKET OR	NBR
36	SEAL HOLDER COVER	STAINLESS STEEL AISI 316
98	DIFFUSER BODY	TECHNOPOLYMER
304	REAR DISK	TECHNOPOLYMER

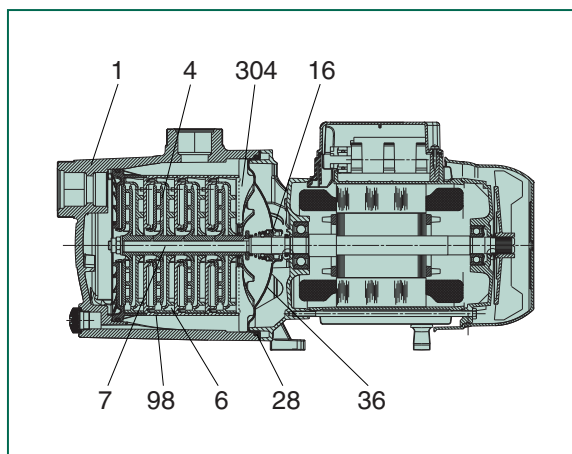

- Operating range: from 10 to 80 l/min. with head up to 58 m.
- Pumped liquid: clean, free from solids and abrasive substances, water coming from swimming pools (containing chlorine).
- Liquid temperature range: from 0°C to +35°C for domestic use (EN 60335-2-41)
from 0°C to +40°C for other uses.
- Maximum ambient temperature: +40°C
- Maximum operating pressure: 6 bar (600 kPa)
- Installation: fixed or portable in horizontal position

The performance curves are based on the kinematic viscosity values = 1 mm²/s and density equal to 1000 Kg/m³. Curve tolerance according to ISO 9906.
 Liquid temperature range: from 0 °C to +35°C Maximum ambient temperature: +40°C

EUROCOM SP 50

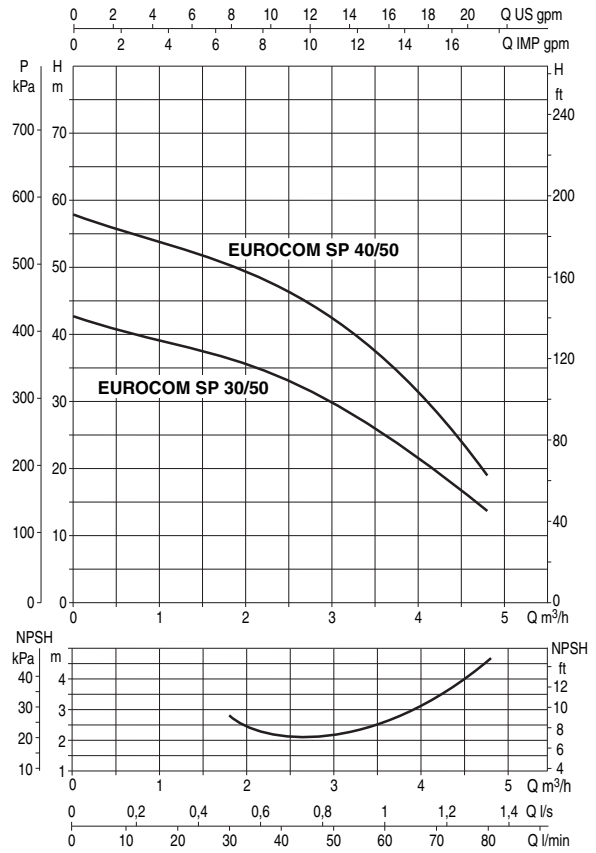
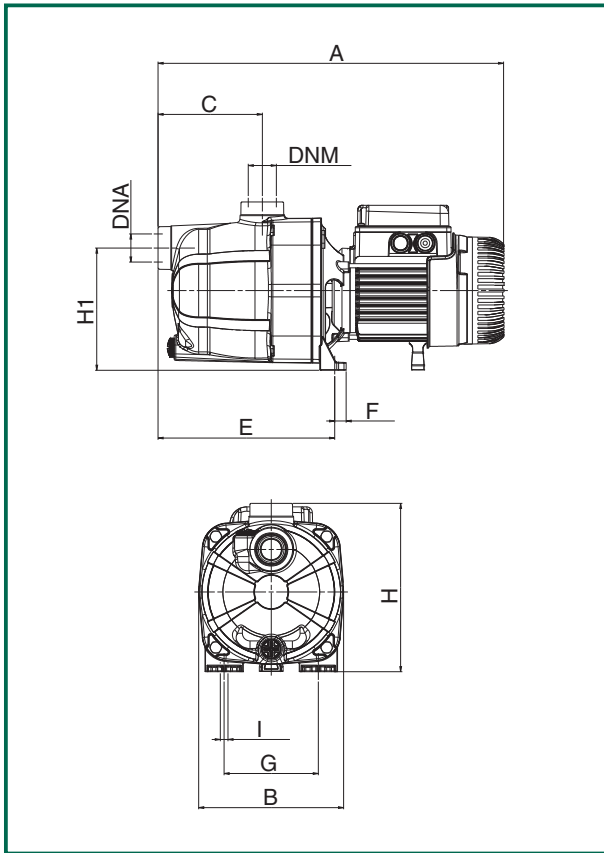

MODEL	A	B	C	E	F	G	I Ø	H	H1	H2	DNA	DNM	PACKING DIMENSIONS			VOLUME m ³	WEIGHT	
													L/A	L/B	H		M Kg	T
EUROCOM SP 30/50	406	170	122	208	14	111	9	198	144	-	1" G	1" G	470	240	240	0,027	8,8	8,8
EUROCOM SP 40/50	406	170	122	208	14	111	9	203	144	-	1" G	1" G	470	240	240	0,027	11	11,3

MODEL	ELECTRICAL DATA							HYDRAULIC DATA (n = 2800 1/min)											
	VOLTAGE 50 Hz	P1 MAX kW	P2 NOMINAL		In A	CAPACITOR		Q											
			kW	HP		µF	Vc	m ³ /h	0	0,6	1,2	1,8	2,4	3	3,3	3,6	4,2	4,8	
EUROCOM SP 30/50 M	1x220-240 V ~	0,88	0,55	0,75	3,9	12,5	450	H (m)	42,2	40,2	38,2	36,2	33,8	30	27,5	24,8	19,5	14	
EUROCOM SP 30/50 T	3x230-400 V ~	0,87	0,55	0,75	2,8-1,6	-	-		57,7	55,3	52,8	50,1	47,1	42,7	39,5	35,8	28	19,2	
EUROCOM SP 40/50 M	1x220-240 V ~	1,2	0,75	1	5,3	20	450												
EUROCOM SP 40/50 T	3x230-400 V ~	1,18	0,75	1	3,8-2,2	-	-												

EUROCOVER



GENERAL DATA

Applications

Totally automatic electric submersible pump, with wide support base specially designed to increase stability and enable the option of operation in positions not totally perpendicular to the ground.

Integrated float for automatic operation, efficient and maintenance-free operation pump.

Suitable for use during the winter period above the pool covers, to remove rainwater and avoid damage to the cover due to the excessive weight of the accumulated water.

If necessary, suitable for emptying the swimming pool before the winter period or in general as a submersible emptying and draining pump or as a portable pump in the event of an emergency.

Constructional characteristics

- Electric pump totally constructed in thermoplastic water resistant material.
- Motor, motor shaft and hardware in stainless steel.
- Triple interposed ring seal with oil pre-chamber.
- Integrated float for automatic operation, inserted in special housing accessible for seasonal cleaning when required.

Motor characteristics

- Continuous duty asynchronous submersible motor.
- Stator inserted in a stainless steel enclosure and covered with a cap to enclose wiring and capacitor.
- IP68 Protection rating
- Insulation class F
- Supply voltage: single-phase 230V 50Hz
- Supplied with 10 metres of cable and schuko socket, 10 metres of cord to facilitate positioning above covers.
- A multi-hose fitting with clapet valve to simplify installation further.

Technical data

- Operating range: from 0.5 to 6 m³/h with head up to 6.5 m.
- Liquid temperature range: from 0 to 35°C (EN 60335-2-41)
- Installation: fixed or portable in vertical position (max inclination 10°)
- Particle size transit: 5 mm
- Automatic Start /stop: start 55mm, stop 35mm

The performance curves are based on the kinematic viscosity values = 1 mm²/s and density equal to 1000 Kg/m³. Curve tolerance according to ISO 9906.
 Liquid temperature range: from 0 °C to +35°C Maximum ambient temperature: +40°C

EUROCOVER

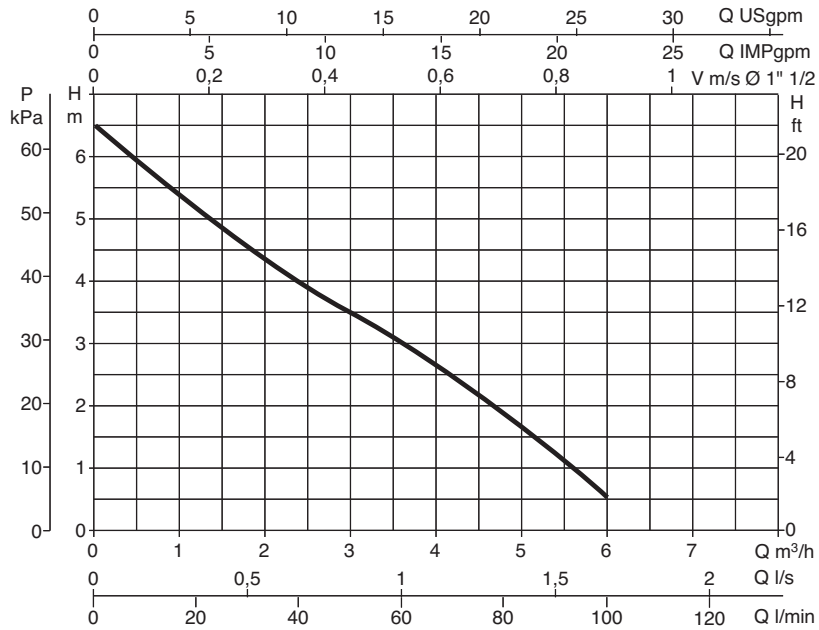

ELECTRIC DATA

MODEL	ELECTRICAL DATA					Q m ³ /h l/min	HYDRAULIC DATA (n ≈ 2800 1/min)					
	VOLTAGE 50 Hz	P1 MAX W	P2 HP	CAPACITOR			0	1,2	2,4	3,6	4,8	6
				μF	Vc	H (m)						
EUROCOVER	230 V ~	250	0,3	8	-		6,5	5,1	4	3	1,9	0,5

ACTIVE SWITCH

SYSTEM FOR THE EXPLOITATION OF RAINWATER

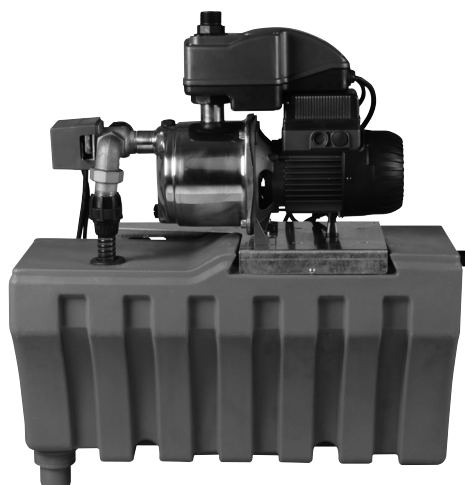

GENERAL DATA

Applications

The ACTIVE SWITCH unit is used for the management and distribution of rain water. The unit detects the lack of water in both rain water and mains collection system and corrects it to guarantee that the system operates correctly (or rather, it never lets the identified users run out of water). The system is generally limited to irrigation, washing machine, WC flushing tank and floor cleaner systems. The main objective of the ACTIVE SWITCH system is to give priority to the use of rain water over that of the mains water. When the rain water contained in the collection tank is insufficient, the control unit passes to the mains water supply thereby ensuring a flow of water at the extraction points (The water supplied by the unit is not drinkable). The connection between the rain water collection tank and the mains water collection tank, which is integrated into the system, is selected by a three-way valve fitted to the pump suction. The pump operates exactly the same as a pump with a "start-stop" system using flow and pressure control. When the pressure drops below the set value the pump starts, when the tap is turned off the pump stops, if there is a lack of water the pump stops and a warning is signalled on the pump's control panel. After a preset time the pump automatically starts again and if all operations are within the set parameters the pump carries on operating normally. The system also includes a special anti-stench and anti-draining trap.

Constructional features

The system comprises a recyclable polyethylene tank, an automatic pump Active EI 30/50 M series and a three-way automatic valve assembled on suction port of the pump. The system has been designed to be wall-mounted. Supplied with wall bracket and float switch with 20 mt. of cable as standard.

Technical specifications

- Ambient temperature: min +5°C - max +40°C
- Flow rate: 80 l/min
- Head max: 42,2 m
- Pumped liquid temperature: da +5°C a +35°C
- Maximum system pressure: 6 bar (600 KpA)
- Maximum mains pressure: 4 bar (400 KpA)
- Maximum usage height: 15 mt
- Mains water pipe dimensions: 3/4"
- Discharge pipe dimensions: 1"
- Suction pipe dimensions: 1"
- Overflow dimensions: DN50

The performance curves are based on the kinematic viscosity values = 1 mm²/s and density equal to 1000 Kg/m³. Curve tolerance according to ISO 9906.

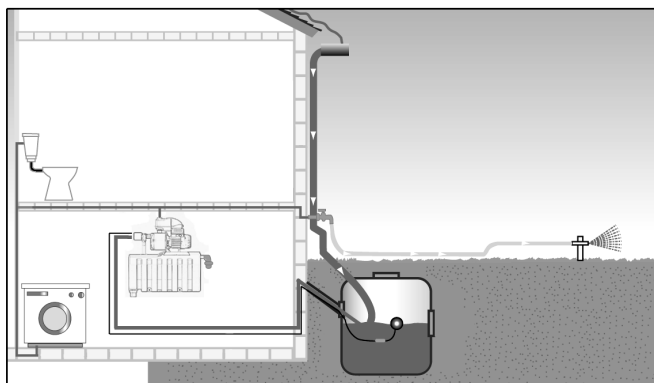

ACTIVE SWITCH - INSTALLATION PLAN

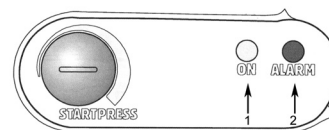
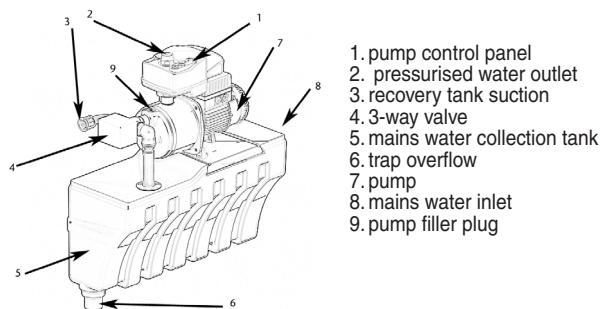
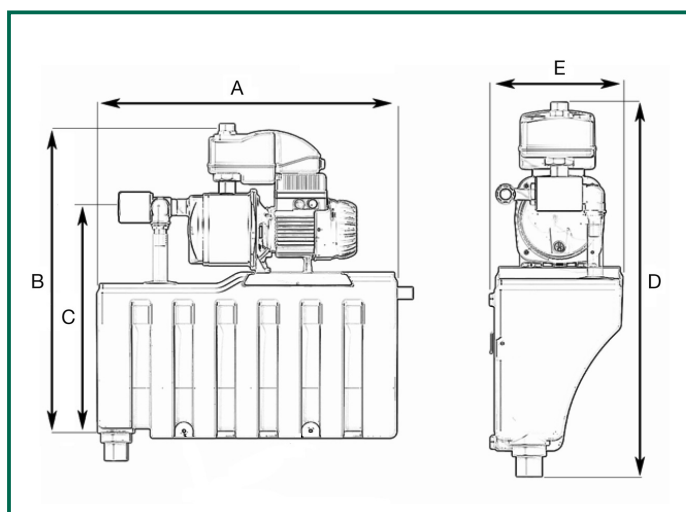
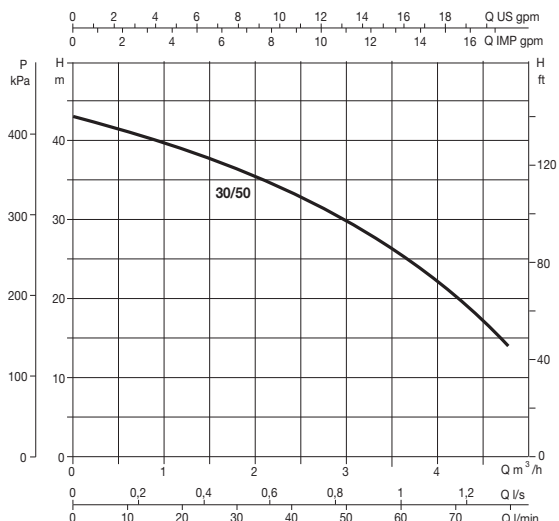

CONTROL PANEL

MODEL	VOLTAGE 50 HZ	ELECTRICAL DATA						HYDRAULIC DATA (N.2800 1/min)											
		N IMPELLERS	P1 max W	P2 Nomin.		In A	CAPACITOR												
				kW	HP		µF	VC	m³/h	0	0,6	1,2	1,8	2,4	3,0	3,6	4,2	4,8	
ACTIVE SWITCH 30/50	1X220-240V	3	0,880	0,55	0,75	3,9	12,5	450	H (m)	42,2	40,2	38,2	36,2	33,8	30	24,8	19,5	14	

MODEL	A	B	C	D	E	WEIGHT KG
ACTIVE SWITCH 30/50	650	666,5	501,5	731,5	260	18

AQUAPROF

SYSTEM FOR THE EXPLOITATION OF RAINWATER



GENERAL DATA

Applicazioni

The AQUAPROF unit is used for the management and distribution of rain water. The unit detects the lack of water in both rain water and mains collection system and corrects it to guarantee that the system operates correctly (or rather, it never lets the identified users run out of water). Notify in the event of faults and indicate the type of problem incurred. The system is generally limited to irrigation, washing machine, WC flushing tank and floor cleaner systems. The main objective of the AQUAPROF system is to give priority to the use of rain water over that of the mains water. When the rain water contained in the collection tank is insufficient, the control unit passes to the mains water supply thereby ensuring a flow of water at the extraction points (The water supplied by the AQUAPROF is not drinkable). The connection between the rain water collection tank and the mains water collection tank, which is integrated into the system, is selected by a three-way valve fitted to the pump suction. The pump operates exactly the same as a pump with a "start-stop" system using flow and pressure control. When the pressure drops below the set value the pump starts, when the tap is turned off the pump stops, if there is a lack of water the pump stops and a warning is signalled on the pump's controlpanel. After a preset time the pump automatically starts again and if all operations are within the set parameters the pump carries on operating normally. The system also includes a special anti-stench and anti-draining trap. The system performs an operational control of the 3-way valve every 24 hours. The system renews the content of the internal mains water tank every week (the renewal is limited to the request of water used).

Constructional features

The system comprises a recyclable polyethylene console, a completely automatic electronic control unit, three-way automatic valve and electropump Euroinox 30/50 M or Euroinox 40/50 M series. Supplied with wall bracket as a standard and float switch with 20 mt of cable for AQUAPROF BASIC version, or probe sensor level with 20 mt of cable for AQUAPROF TOP. We suggest to buy a dedicated probe with resolution from 2 to 2,5 meters

Technical specifications

- | | | | |
|------------------------------|--|--------------------------------|-----------------|
| • Protection class: | IP42 | • Maximum mains pressure: | 6 bar (600 KpA) |
| • Ambient temperature: | min +5°C - max +40°C | • Maximum usage height: | 25 mt |
| • Flow rate: | 80 l/min | • Capacity of the tank: | 4,5 lt |
| • Head max: | 42,2 m (Aquaprof 30/50)
57,7 m (Aquaprof 40/50) | • Mains water pipe dimensions: | 3/4" |
| • Pumped liquid temperature: | from +5°C a +35°C | • Discharge pipe dimensions: | 1" |
| • Maximum system pressure: | 6 bar (600 KpA) | • Suction pipe dimensions: | 1" |
| | | • Overflow dimensions: | DN50 |

The performance curves are based on the kinematic viscosity values = 1 mm²/s and density equal to 1000 kg/m³. Curve tolerance according to ISO 9906.

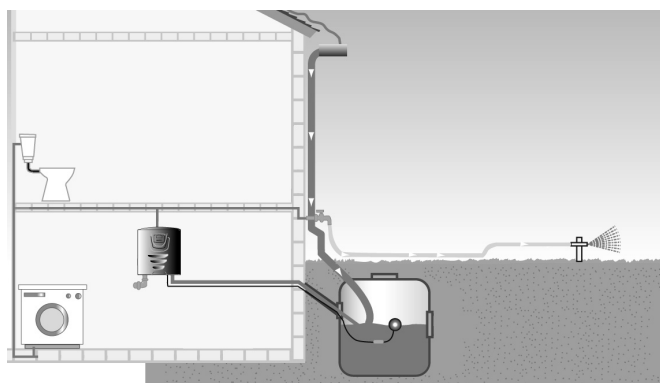

AQUAPROF BASIC AND TOP - INSTALLATION PLAN

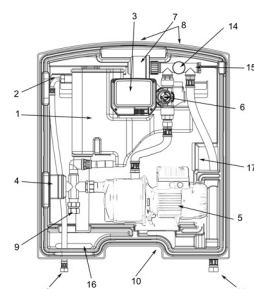
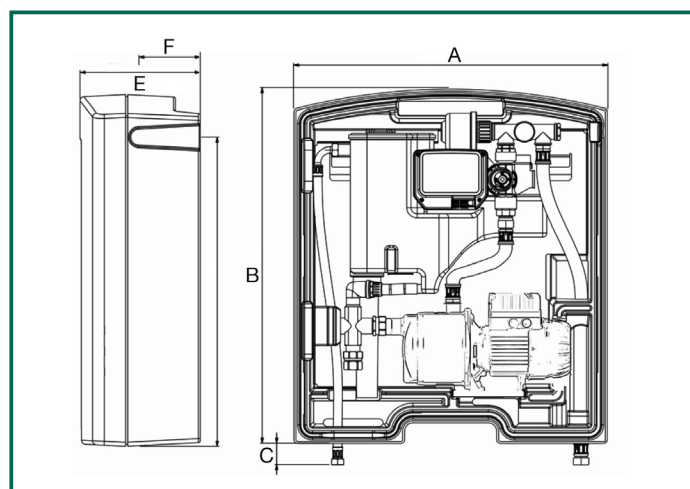
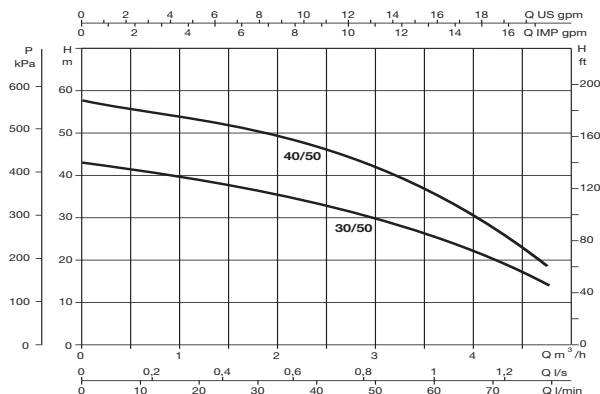

- 1. mains water tank
- 2. mains water inlet
- 3. control panel
- 4. 3-way valve
- 5. pump
- 6. pump hydraulic control system
- 7. anti-dripping plenum
- 8. hot air outlet
- 9. rain water suction
- 10. pump cooling air intake
- 11. pressurised water outlet
- 12. rear casing
- 13. emergency overflow
- 14. pressure gauge
- 15. horizontal outlet
- 16. pipes and electrical cable opening
- 17. delivery pipe opening
- 18. pump filler plug

CONTROL PANEL

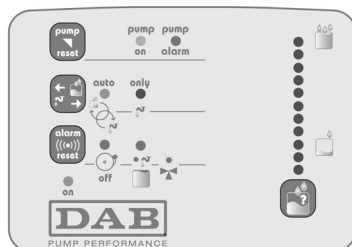

AQUAPROF BASIC

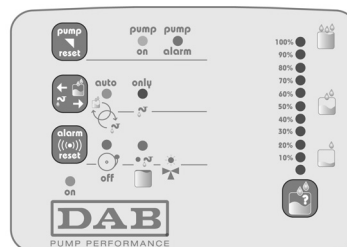

AQUAPROF TOP

MODEL	VOLTAGE 50 HZ	ELECTRICAL DATA							HYDRAULIC DATA (N.2800 1/min)																
		N IMPELLERS	P1 max W	P2 Nomin.		I _n A	CAPACITOR		Flow Rate (Q)																
				kW	HP		μF	VC	m ³ /h	0	0,6	1,2	1,8	2,4	3,0	3,3	3,6	4,2	4,8						
AQUAPROF BASIC 30/50	1X220-240V	3	0,88	0,55	0,75	3,9	12,5	450	H (m)	42,2	40,2	38,2	36,2	33,8	30	27,5	24,8	19,5	14						
AQUAPROF BASIC 40/50	1X220-240V	4	1,2	0,75	1	5,3	20	450		57,7	55,3	52,8	50,1	47,1	42,7	39,5	35,8	28	19,2						
AQUAPROF TOP 30/50	1X220-240V	3	0,88	0,55	0,75	3,9	12,5	450		42,2	40,2	38,2	36,2	33,8	30	27,5	24,8	19,5	14						
AQUAPROF TOP 40/50	1X220-240V	4	1,2	0,75	1	5,3	20	450		57,7	55,3	52,8	50,1	47,1	42,7	39,5	35,8	28	19,2						

MODEL	A	B	C	D	E	F	WEIGHT KG
AQUAPROF BASIC 30/50	750	850	50,5	747	290	148	28
AQUAPROF BASIC 40/50	750	850	50,5	747	290	148	32
AQUAPROF TOP 30/50	750	850	50,5	747	290	148	28
AQUAPROF TOP 40/50	750	850	50,5	747	290	148	32

**DAB PUMPS LTD.**

Unit 4, Stortford Hall Industrial
Park Dunmow Road, Bishops Stortford, Herts
CM23 5GZ - UK
Tel. +44 1279 652 776
Fax +44 1279 657 727

**DAB PUMPS B.V.**

Albert Einsteinweg, 4
5151 DL Drunen - Nederland
Tel. +31 416 387280
Fax +31 416 387299
info.nl@dabpumps.com

**DAB PUMPS B.V.**

Brusselstraat 150
B-1702 Groot-Bijgaarden - Belgium
Tel. +32 2 4668353
Fax +32 2 4669218

**DAB PUMPEN DEUTSCHLAND GmbH**

Tackweg 11
D - 47918 Tönisvorst - Germany
Tel. +49 2151 82136-0
Fax +49 2151 82136-36

**PUMPS AMERICA, INC. DAB PUMPS DIVISION**

3226 Benchmark Drive
Ladson, SC 29456 USA
Ph. 1-843-824-6332
Toll Free 1-866-896-4DAB (4322)
Fax 1-843-797-3366

**DAB PUMPS IBERICA S.L.**

Parque Empresarial San Fernando
Edificio Italia Planta 1ª
28830 - San Fernando De Henares - Madrid
Spain
Ph. +34 91 6569545
Fax +34 91 6569676

**DAB PUMPS RUSSIA**

127247 Dmitovskoe sh., 100 bld. 3
Moscow, Russia
Tel +7 095 485-1679

**DAB PUMPS CHINA**

Shandong Sheng Qingdao Shi
Jinji Jishu Kaifagu Kaituo Rd
ZIP PC266510
CN - China
Tel. +8613608963089
Fax. +8653286812210

**DAB PUMPS S.p.A.**

Via M. Polo, 14 - 35035 Mestrino (PD) - Italy
Tel. +39 049 9048811 - Fax +39 049 9048847
<http://www.dabpumps.com>

Vendite Italia:

Tel. 049 9048873-75-76
049 9048950
Fax 049 9048888

Export Sales Dept:

Ph. (+39) 049 9048895-96-97
049 9048964-996
Fax (+39) 049 9048900

Assistenza Tecnica Clienti:

Customer Technical Assistance: Ph. (+39) 049 9048911
Fax (+39) 049 9048920