

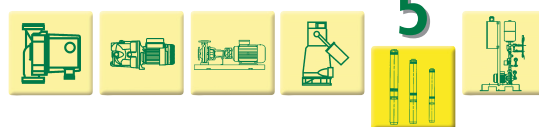





SUBMERGED PUMPS



DAB
PUMP PERFORMANCE

DWT GROUP
PUMPS • MOTORS • ELECTRONICS

TECHNICAL CATALOGUE SECTIONS:

- 1  WET ROTOR CIRCULATORS AND IN-LINE PUMPS
- 2  SELF-PRIMING AND MULTISTAGE CENTRIFUGAL PUMPS
- 3  CENTRIFUGAL PUMPS
- 4  SUBMERSIBLE PUMPS
- 5  **SUBMERGED PUMPS**
- 6  BOOSTER SETS

CONTENTS

3"	BOREHOLE PUMPS	MICRA	pag. 7-9
4"	BOREHOLE PUMPS SUBMERGED MOTORS	IDEA CS4 S4 4GG 4TW 40L	pag. 10-33
5"	BOREHOLE PUMPS	DIVER DIVER HF PULSAR PULSAR DRY	pag. 34-45
6"	BOREHOLE PUMPS SUBMERGED MOTORS	S6 6GF 6GX TR6	pag. 46-59
8"	SUBMERGED MOTORS	TR8	pag. 60-61
10"	SUBMERGED MOTORS	TR10	pag. 62-63
12"	SUBMERGED MOTORS	TR12	pag. 64-65

BOREHOLE PUMPS

PERFORMANCE RANGE

GRAPHIC SELECTION TABLE

The performance curves are based on kinematic viscosity values = 1 mm²/s and density equivalent to 1000 kg/m³. Tolerance of curves to ISO 9906.

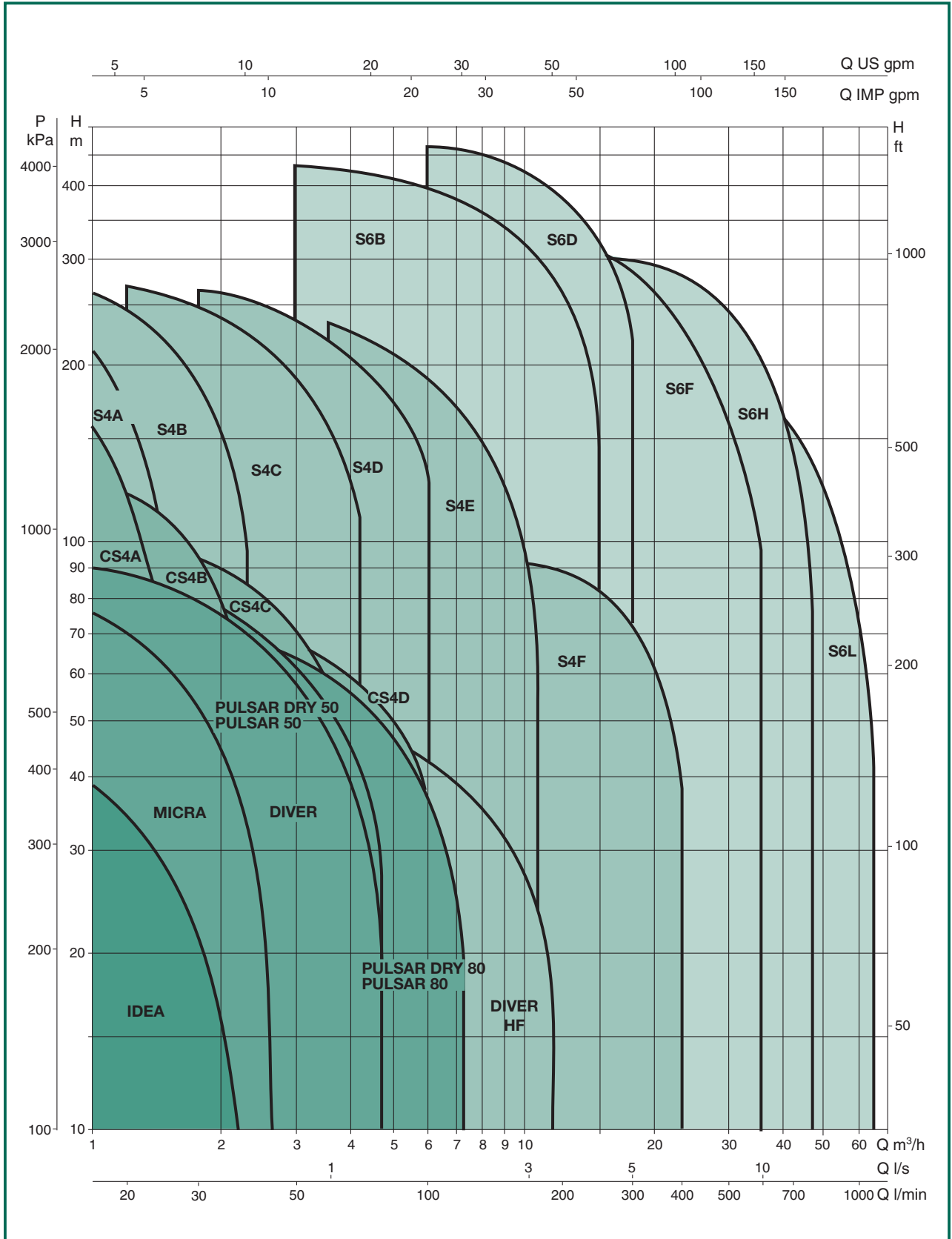

PERFORMANCE RANGE OF MICRA - IDEA - CS4 - S4

SELECTION TABLE

MODEL		P2 NOMINAL		Q m³/h																
SINGLE PHASE	THREE-PHASE	kW	HP		0	0,6	1,2	1,5	1,8	2,4	3	4,2	4,8	6	9	11,4	18	24	27	
				l/min	0	10	20	25	30	40	50	70	80	100	150	190	300	400	450	
MICRA 50 M	MICRA 50 T	0,37	0,5	H (m)	49	41	35	31	27	14										
MICRA 75 M	MICRA 75 T	0,55	0,75		72	64	54	48	42	23										
MICRA 100 M	MICRA 100 T	0,75	1		97	84	72	65	56	30										
IDEA 75 M	IDEA 75 M	0,37	0,5	H (m)	47	37	27,6	22,5	17,6	6,8										
IDEA 100 M	IDEA 100 M	0,75	1		61,8	48,3	34,6	28	21,2	7,3										
CS4A-8 M	-	0,25	0,33		51	44,4	26,8	13,7												
CS4A-12 M	CS4A-12 T	0,37	0,5	H (m)	76,5	66,6	40,2	20,5												
CS4A-18 M	CS4A-18 T	0,55	0,75		114,8	99,8	60,3	30,8												
CS4A-25 M	CS4A-25 T	0,75	1		159,4	138,7	83,7	42,7												
CS4A-36 M	CS4A-36 T	1,1	1,5		229,5	200	120,6	61,6												
CS4B-5 M	-	0,25	0,33		31	30	26	22,6	19	10										
CS4B-8 M	CS4B-8 T	0,37	0,5		49,6	47,8	41,5	36,2	30,6	16										
CS4B-12 M	CS4B-12 T	0,55	0,75		74,4	71,8	62,3	54,4	45,8	24										
CS4B-16 M	CS4B-16 T	0,75	1		99,2	95,7	83	72,5	61	32										
CS4B-24 M	CS4B-24 T	1,1	1,5		148,8	143,5	124,6	108,7	91,7	48										
CS4C-6 M	CS4C-6 T	0,37	0,5		33		31,8	30,7	29,4	26,4	22,7	13,2								
CS4C-9 M	CS4C-9 T	0,55	0,75		49,5		47,7	46	44	39,6	34	19,8								
CS4C-13 M	CS4C-13 T	0,75	1		71,5		68,9	66,4	63,7	57,2	49,2	28,6								
CS4C-19 M	CS4C-19 T	1,1	1,5		104,5		100,7	97	93	83,6	71,8	41,8								
CS4D-4 M	CS4D-4 T	0,37	0,5		24				23	22	21,8	18	16,2	11,2						
CS4D-6 M	CS4D-6 T	0,55	0,75		36				34,5	33	31,5	27	24,3	16,8						
CS4D-8 M	CS4D-8 T	0,75	1		48				46	44	42	36	32,5	22,4						
CS4D-13 M	CS4D-13 T	1,1	1,5		78				74,7	71,5	68,3	59	52,6	36,4						
S4A-8 M	-	0,25	0,33		51	44,4	26,8	13,7												
S4A-12 M	S4A-12 T	0,37	0,5		76,5	66,6	40,2	20,5												
S4A-18 M	S4A-18 T	0,55	0,75		114,8	99,8	60,3	30,8												
S4A-25 M	S4A-25 T	0,75	1		159,4	138,7	83,7	42,7												
S4A-36 M	S4A-36 T	1,1	1,5		229,5	200	120,6	61,6												
S4A-50 M	S4A-50 T	1,5	2		318,8	277,4	167,5	85,5												
S4B-5 M	-	0,25	0,33		31	30	26	22,6	19	10										
S4B-8 M	S4B-8 T	0,37	0,5		49,6	47,8	41,5	36,2	30,6	16										
S4B-12 M	S4B-12 T	0,55	0,75		74,4	71,8	62,3	54,4	45,8	24										
S4B-16 M	S4B-16 T	0,75	1		99,2	95,7	83	72,5	61	32										
S4B-24 M	S4B-24 T	1,1	1,5		148,8	143,5	124,6	108,7	91,7	48										
S4B-32 M	S4B-32 T	1,5	2		198,4	191,4	166	144,9	122,2	64										
S4B-40 M	S4B-40 T	2,2	3		248	239,2	207,6	181,2	152,8	80										
S4B-48 M	S4B-48 T	2,2	3	297,6	287,1	249,2	217,4	183,4	96											
S4C-6 M	S4C-6 T	0,37	0,5	33		31,8	30,7	29,4	26,4	22,7	13,2									
S4C-9 M	S4C-9 T	0,55	0,75	49,5		47,7	46	44	39,6	34	19,8									
S4C-13 M	S4C-13 T	0,75	1	71,5		68,9	66,4	63,7	57,2	49,2	28,6									
S4C-19 M	S4C-19 T	1,1	1,5	104,5		100,7	97	93	83,6	71,8	41,8									
S4C-25 M	S4C-25 T	1,5	2	137,5		132,5	128	122,5	110	94,5	55									
S4C-32 M	S4C-32 T	2,2	3	176		169,6	163	156,8	140,8	120,9	70,4									
S4C-39 M	S4C-39 T	2,2	3	214,5		206,7	200	191,1	171,6	147,4	85,8									
-	S4C-45 T	3	4	247,5		238,5	229	220,5	198	170,1	99									
-	S4C-51 T	3	4	280,5		270,3	261	250	224,4	192,8	112,2									
S4D-4 M	S4D-4 T	0,37	0,5	24				23	22	21,8	18	16,2	11,2							
S4D-6 M	S4D-6 T	0,55	0,75	36				34,5	33	31,5	27	24,3	16,8							
S4D-8 M	S4D-8 T	0,75	1	48				46	44	42	36	32,5	22,4							
S4D-13 M	S4D-13 T	1,1	1,5	78				74,7	71,5	68,3	59	52,6	36,4							
S4D-17 M	S4D-17 T	1,5	2	102				98	93,5	89,5	77,5	68,8	47,6							
S4D-21 M	S4D-21 T	2,2	3	126				121	115,5	110	96	85	58,8							
S4D-25 M	S4D-25 T	2,2	3	150				144	137,5	132	114,5	101,2	70							
-	S4D-29 T	3	4	174				166	159,5	152	132	117,4	81,2							
-	S4D-34 T	3	4	204				196	187	179,5	155	137,7	95,2							
-	S4D-38 T	4	5,5	228				219	209	200	173	153,9	106,4							
-	S4D-45 T	4	5,5	270				259	247,5	237	205	182,2	127							
S4E-6 M	S4E-6 T	0,75	1	40,5							31,5	30	27	17,6	7,7					
S4E-8 M	S4E-8 T	1,1	1,5	54							42	40	37	23,4	10,3					
S4E-12 M	S4E-12 T	1,5	2	81							63	60	55	35,2	15,5					
S4E-17 M	S4E-17 T	2,2	3	114,8							89,5	86	78	49,8	21,9					
-	S4E-20 T	3	4	135							105	101,5	91	58,6	25,7					
-	S4E-23 T	3	4	155,4							120,5	117	104,5	67,4	29,6					
-	S4E-27 T	4	5,5	182,4							141,5	137	122,5	79,2	34,8					
-	S4E-31 T	4	5,5	209,4							162	156	140	90,9	39,9					
-	S4E-36 T	5,5	7,5	243,2							188	180	162	105,5	46,5					
-	S4E-42 T	5,5	7,5	283,7							220	211	189	123,2	54					
S4F-7 M	S4F-7 T	2,2	3	40,5										36	33	24	15	11		
-	S4F-10 T	3	4	58										50,8	47	34	22	16		
-	S4F-13 T	4	5,5	76										66	62	44,7	28	20		
-	S4F-18 T	5,5	7,5	104,5										91	84	61,2	39	28		

DIVER - DIVER HF - PULSAR - PULSAR DRY - S6 PERFORMANCE RANGE

SELECTION TABLE

MODEL		P2 NOMINAL		Q m³/h l/min	H (m)															
SINGLE PHASE	THREE-PHASE	KW	HP		0	2,4	4,8	6	7,8	8,4	10,8	12	15	18	24	36	48	54	66	
DIVER 75 M	DIVER 75 T	0,55	0,75	H (m)	39	26	9													
DIVER 100 M	DIVER 100 T	0,75	1		55	35	11													
DIVER 150 M	DIVER 150 T	1,1	1,5		80	52	16													
DIVER 200 M	DIVER 200 T	1,5	2		101	70	21													
DIVER 100 M HF	DIVER 100 T HF	0,75	1		30	27	23	22	19	17	13	10								
DIVER 150 M HF	DIVER 150 T HF	1,1	1,5		42	38	34	32	27	25	19	15								
DIVER 200 M HF	DIVER 200 T HF	1,5	2	59	53	47	44	38	36	26	20									
PULSAR 20/50 M	PULSAR 20/50 T	0,55	0,75	H (m)	29	23,2	10,3													
PULSAR 30/50 M	PULSAR 30/50 T	0,55	0,75		42	33,8	13,5													
PULSAR 40/50 M	PULSAR 40/50 T	0,75	1		56	45	18													
PULSAR 50/50 M	PULSAR 50/50 T	1	1,36		72	58	24,5													
PULSAR 65/50 M	PULSAR 65/50 T	1,2	1,6		86	70	29													
PULSAR 30/80 M	PULSAR 30/80 T	0,75	1		51	44,8	39,4	23,5												
PULSAR 40/80 M	PULSAR 40/80 T	1	1,36	64	56,8	41,5	30,5													
PULSAR 50/80 M	PULSAR 50/80 T	1,2	1,6	77	68	50	37													
PULSAR DRY 20/50 M	PULSAR DRY 20/50 T	0,55	0,75	H (m)	29	23,2	10,3													
PULSAR DRY 30/50 M	PULSAR DRY 30/50 T	0,55	0,75		42	33,8	13,5													
PULSAR DRY 40/50 M	PULSAR DRY 40/50 T	0,75	1		56	45	18													
PULSAR DRY 50/50 M	PULSAR DRY 50/50 T	1	1,36		72	58	24,5													
PULSAR DRY 65/50 M	PULSAR DRY 65/50 T	1,2	1,6		86	70	29													
PULSAR DRY 30/80 M	PULSAR DRY 30/80 T	0,75	1		51	44,8	32,4	23,5												
PULSAR DRY 40/80 M	PULSAR DRY 40/80 T	1	1,36	64	56,8	41,5	30,5													
PULSAR DRY 50/80 M	PULSAR DRY 50/80 T	1,2	1,6	77	68	50	37													
-	S6B-9	4	5,5	H (m)	147			125	120	114	96	85	46							
-	S6B-12	5,5	7,5		196			172	160	152	128	113	64							
-	S6B-15	7,5	10		224			216	198	190	160	141	80							
-	S6B-18	9,2	12,5		293			250	238	228	193	169	96							
-	S6B-21	9,2	12,5		342			291	278	266	225	197	112							
-	S6B-24	11	15		391			340	315	304	257	226	128							
-	S6B-28	13	17,5		446			400	370	354	300	263	149							
-	S6D-6	3,7	5		94					87	80	76	63	44						
-	S6D-7	5,5	7,5		109					101	93	89	74	51						
-	S6D-8	5,5	7,5		125					115	106	102	84	58						
-	S6D-9	5,5	7,5		140					130	120	114	95	66						
-	S6D-12	7,5	10		187					173	160	153	127	88						
-	S6D-15	9,2	12,5		234					216	201	191	158	110						
-	S6D-18	11	15		281					260	241	229	190	132						
-	S6D-21	13	17,5		328					304	281	267	222	154						
-	S6D-24	15	20		374					347	321	305	254	176						
-	S6D-30	18,5	25		468					464	401	381	317	220						
-	S6F-4	4	5		61							53	51	48	40	15				
-	S6F-6	5,5	4,5		91							80	76	71	59	22				
-	S6F-8	7,5	10		122							106	101	95	79	30				
-	S6F-10	9,2	12,5		152							133	126	119	99	37				
-	S6F-12	11	15		182							159	154	143	119	47				
-	S6F-14	13	17,5		213							186	178	167	139	56				
-	S6F-16	15	20		243							212	204	190	158	64				
-	S6F-20	18,5	25		304							265	255	238	198	80				
-	S6F-24	22	30		365							318	305	286	238	96				
-	S6H-3	4	5,5	48									42	39	30	12				
-	S6H-4	5,5	7,5	63									57	53	40	16				
-	S6H-5	7,5	10	78									71	66	50	20				
-	S6H-6	9,2	12,5	94									85	80	60	23				
-	S6H-8	11	15	126									114	106	80	31				
-	S6H-9	13	17,5	141									128	120	90	35				
-	S6H-10	15	20	157									142	133	100	39				
-	S6H-12	18,5	25	188									170	160	1200	47				
-	S6H-15	22	30	235									213	199	150	59				
-	S6H-18	26	35	283									256	239	180	71				
-	S6H-20	30	40	314									284	266	200	78				
-	S6L-3	5,5	7,5	40											28	22	18	7		
-	S6L-4	7,5	10	52											38	29	23	9		
-	S6L-5	9,2	12,5	65											48	36	29	11		
-	S6L-6	11	15	78											57	44	36	13		
-	S6L-8	13	17,5	104											77	58	47	18		
-	S6L-9	15	20	118											86	66	53	20		
-	S6L-10	18,5	25	131											96	73	59	23		
-	S6L-12	22	30	158											114	88	71	27		
-	S6L-15	26	35	197											144	110	89	34		
-	S6L-18	30	40	236											173	130	106	41		

PUMPS – PROTECTION SYSTEMS CONNECTION DIAGRAMS

Single-phase borehole pumps

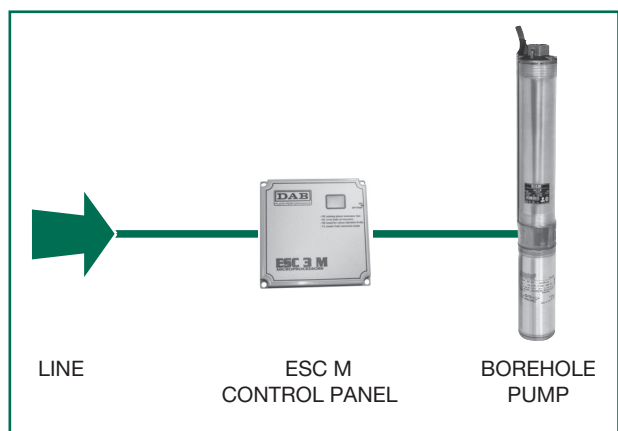
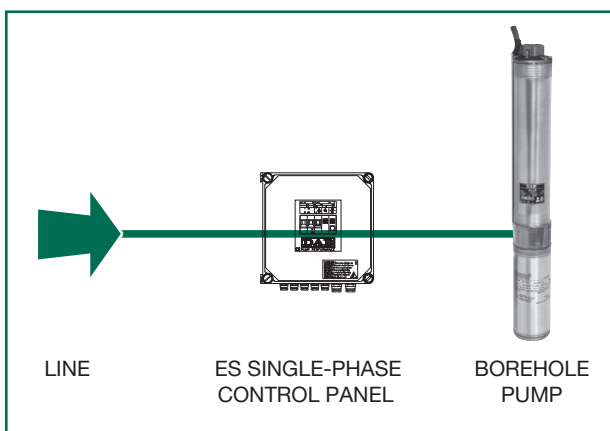
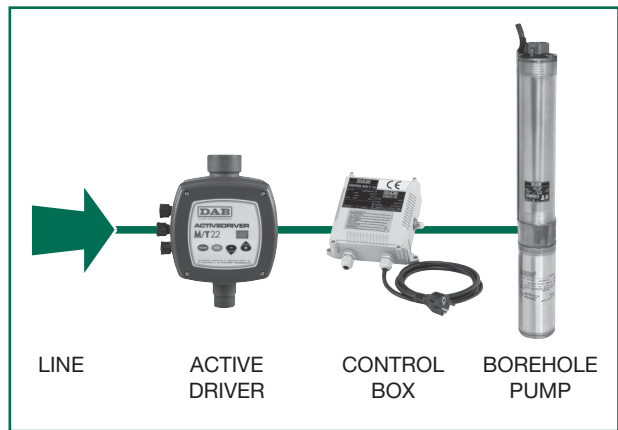
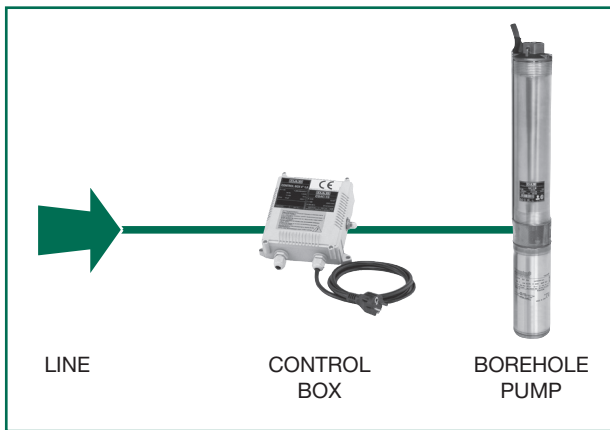

Three-phase borehole pumps

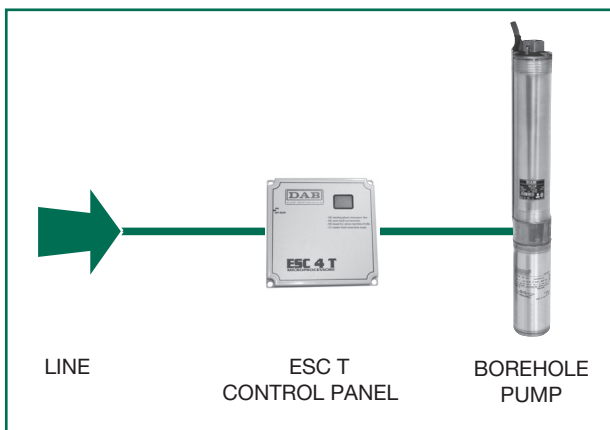
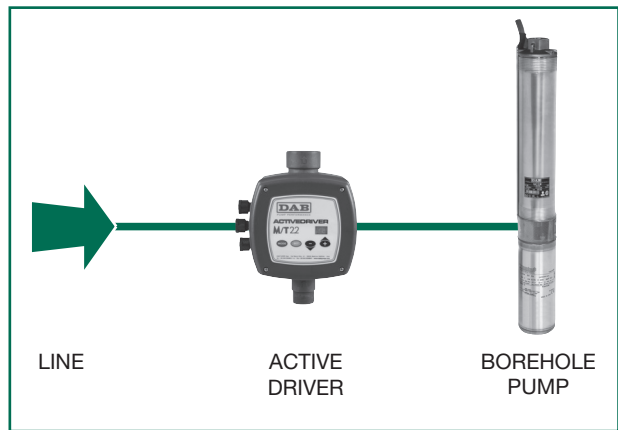
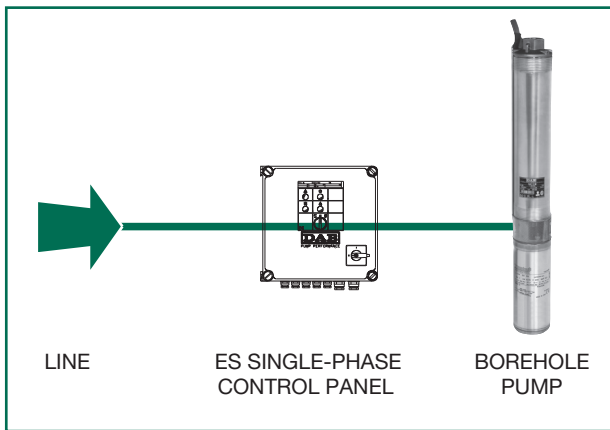

MICRA



(Control box only for single-phase version)

GENERAL DATA

Applications

Borehole electric pumps for 3" wells or larger.

These units have a very extensive range of applications for lifting and distribution in domestic and industrial water systems, filling of pressure vessels and tanks, pressurisation and irrigation systems.

Pump construction features

Multistage centrifugal type. Directly coupled pump and motor with rigid coupling. Impellers and thrust rings in Noryl and diffusers in self-lubricating polyacetyl. Pump liner, shaft and coupling, strainer and cable sheath in stainless steel.

Base support and head in brass with check valve incorporated in head.

Motor construction characteristics

Submerged asynchronous two-pole motor made entirely of AISI 304 stainless steel with brass bearings.

Squirrel cage rotor in copper mounted on Kingsbury thrust block.

Cooling of the thrust bearing assembly and the bushings is provided by water, thereby eliminating the risk of oil contamination. Canned-type stator in an airtight casing made of AISI 304L stainless steel. The automatic reset thermal protection device is integral with the motor.

Protection rating: IP68

Heat insulation class: F

Input voltage: single-phase 220-230 V / 50Hz
trifase 400 V / 50Hz

TECHNICAL DATA

No.	PART*	MATERIAL
PUMP		
1	BASE SUPPORT	BRASS OT58
2	ROTOR	NORYL GFN2
3	DIFFUSER	POLYACETYL
4	SHAFT WITH COUPLING	AISI 430F
5	ROTOR'S LOCKING NUT	AISI 304
6	CABLE SHEATH	AISI 430
7	STRAINER	AISI 430
8	VALVE	POLYACETYL
9	DISCHARGE SECTION	BRASS OT58
10	PUMP LINER	AISI 304
11	BUSHES	AISI 316L
MOTOR		
12	INTERNAL AND OUTER LINER	AISI 304
13	SHAFT	AISI 431
14	UPPER SUPPORT	BRASS OT58
15	LOWER SUPPORT	BRASS OT58
16	LIP SEAL	NBR
17	GASKETS	NBR
18	BELLOW SEAL	EPDM
19	CABLE	EPDM
20	CONNECTOR PLUG	AISI 304
21	SAND GUARD	NBR
22	SCREWS	AISI 304

* In contact with liquid

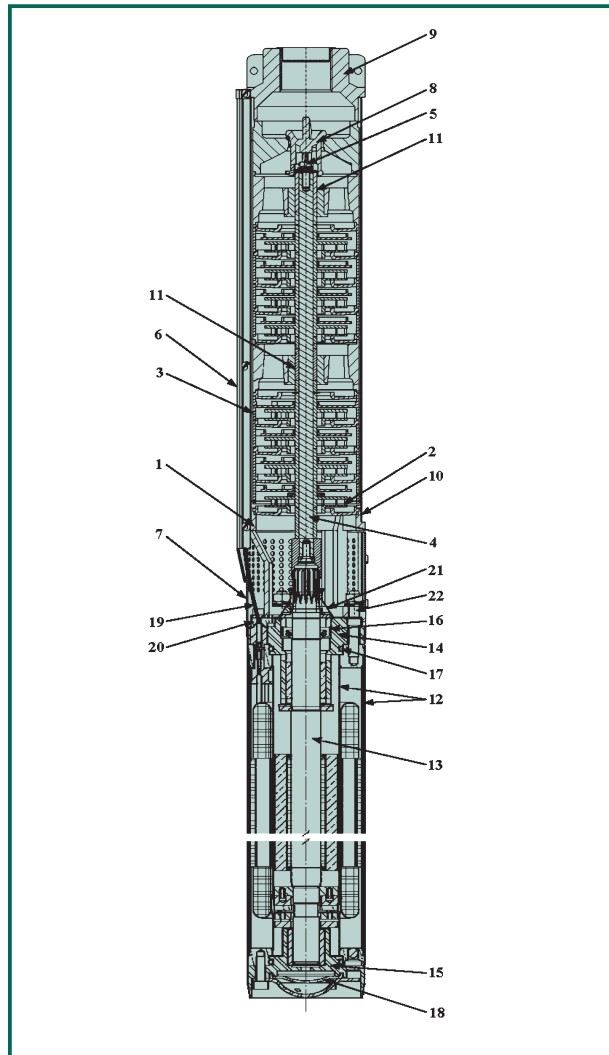

- Operating range: from 0.3 to 2.7 m³/h with head of up to 90 m.
- Liquid quality requirements: clean, free of solid or abrasive contaminants, non-viscous, chemically neutral, close to the properties of water.
- Liquid temperature range: from 0°C to +35°C
- Maximum permissible sand quantity: 40g/m³
- Input voltage tolerance: +6% / -10%
- Max. no. of starts: 20/h
- Installation: in 3" wells or larger, tanks and cisterns, vertical position. In the event of horizontal installation, ensure a minimum load is applied to the thrust bearing assembly.
- Special executions on request: alternative voltages and/or frequencies.
- Power cable: Micra 50 – 1m
Micra 75 – 1,2m
Micra 100 – 1,4m

Single-phase version supplied with CONTROL BOX on request

The performance curves are based on kinematic viscosity values = 1 mm²/s and density equivalent to 1000 kg/m³. Tolerance of curves to ISO 9906.

MICRA

Liquid temperature range: from 0°C to +35°C

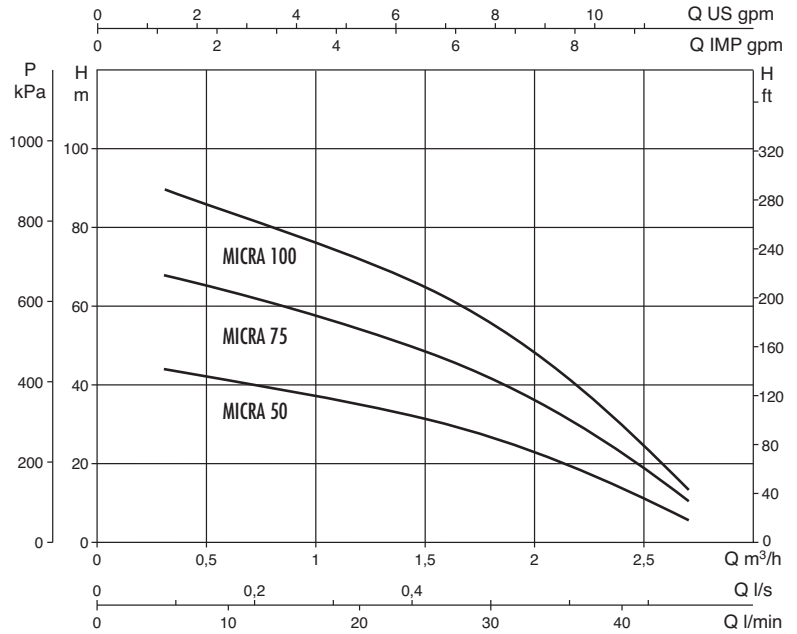
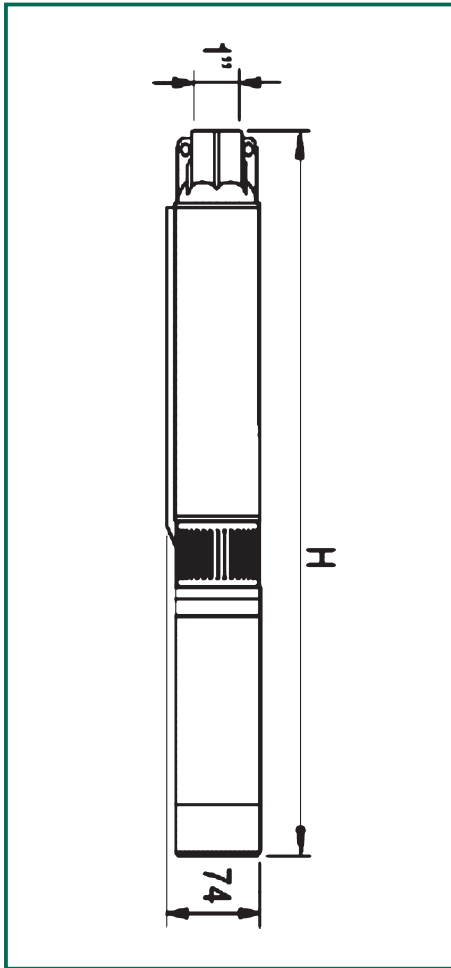

MODEL	Ø	H	DNM	PACK DIMENSIONS		VOLUME m ³	GROSS WEIGHT Kg
				Ø	H		
MICRA 50	74	930	1"	86	1150	0,0067	9
MICRA 75	74	1145	1"	86	1350	0,0078	10,2
MICRA 100	74	1390	1"	86	1600	0,0093	13,6

MODEL	ELECTRICAL DATA							HYDRAULIC DATA (n ≈ 2800 1/min)									
	INPUT VOLTAGE 50 Hz	P1 MAX kW	P2 NOMINAL		In A	CAPACITOR		Q m ³ /h l/min	0,3	0,6	0,9	1,2	1,5	1,8	2,1	2,4	2,7
			kW	HP		µF	Vc		5	10	15	20	25	30	35	40	45
MICRA 50 M	1x230 V ~	0,65	0,37	0,5	3,3	12	450	H (m)	45	41	38	35	31	27	21	14	6
MICRA 50 T	3x400 V ~	0,6	0,37	0,5	1,3	-	-		45	41	38	35	31	27	21	14	6
MICRA 75 M	1x230 V ~	0,95	0,55	0,75	5,1	16	450		68	64	59	54	48	42	33	23	11
MICRA 75 T	3x400 V ~	0,9	0,55	0,75	1,9	-	-		68	64	59	54	48	42	33	23	11
MICRA 100 M	1x230 V ~	1,2	0,75	1	6,1	20	450		90	84	78	72	65	56	44	30	14
MICRA 100 T	3x400 V ~	1,15	0,75	1	2,4	-	-		90	84	78	72	65	56	44	30	14

Single-phase version supplied with CONTROL BOX on request

IDEA



GENERAL DATA

Applications

Single-impeller peripheral borehole pump for 4" wells or larger, capable of providing high heads with limited power. Suitable for water lifting and distribution applications in domestic systems, small agricultural concerns, pressurisation of pressure vessels and DIY uses.

Pump construction features

Pump body and motor support in cast iron.

Brass impeller.

Impeller shaft extension and strainer in stainless steel.

Motor construction characteristics

Submersible asynchronous two-pole motor, made entirely of stainless steel, dry design with external cooling by means of pumped liquid.

Canned-type AISI 304L stator

Squirrel cage rotor running on ball bearings, oversized to ensure reliability and durability

Graphite/alumina mechanical seal and lip seal

In the single phase version the start capacitor is enclosed in a rugged, electrically insulated high-density plastic enclosure.

Overload protection to be provided by the user for the three-phase version.

Protection rating: IP 68

Insulation class: F

Standard input voltage: single phase 230 V / 50 Hz
three-phase 400 V / 50 Hz

Removable H07RN-F power cable, length 15 m.

Supplied with 15 m of nylon rope

TECHNICAL DATA

No.	PART*	MATERIAL
1	CABLE	H07 RNF CEI 20-19
2	IMPELLER	BRASS PCuZn40Pb2 UNI 5705
3	SUPPORT	CAST IRON G20 UNI 5007 (Epoxy electrocoat)
4	MECHANICAL SEAL	GRAPHITE/ALUMINA
5	SHAFT WITH ROTOR	STAINLESS STEEL AISI 431 X17CrNi16 2 UNI 10088-3
6	MOTOR	STAINLESS STEEL AISI 304L X2CrNi19 11 UNI 10088-3
7	CAPACITOR CARTRIDGE	Noryl 20% fibreglass

*In contact with liquid.

- Operating range: from 0.4 to 2.4 m³/h with head of up to 52 m.
- Liquid quality requirements: clean, free of solid or abrasive contaminants, non-viscous, non-aggressive, not crystallised and chemically neutral, close to the properties of water.
- Liquid temperature range: from 0°C to +35°C
- Max. immersion depth: 20 m
- Input voltage tolerance: +6% / -10%
- Max. no. of starts: 20/h
- Installation: in 4" wells or larger, tanks and cisterns, vertical position.
- Special executions on request: alternative voltages and/or frequencies.

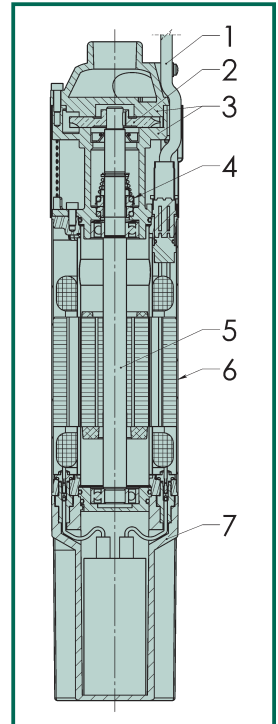

The performance curves are based on kinematic viscosity values = 1 mm²/s and density equivalent to 1000 kg/m³. Tolerance of curves to ISO 9906.

IDEA

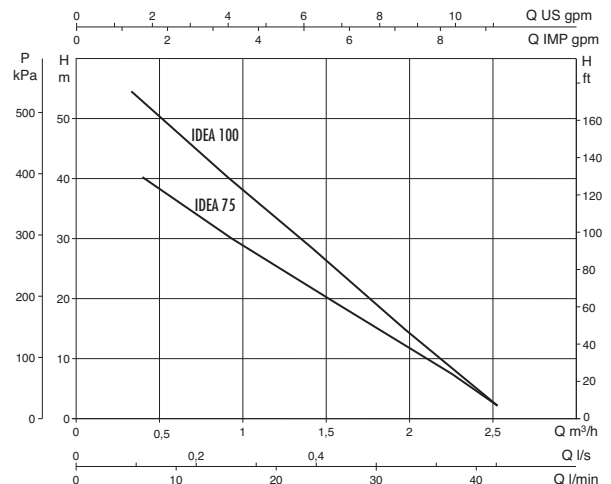
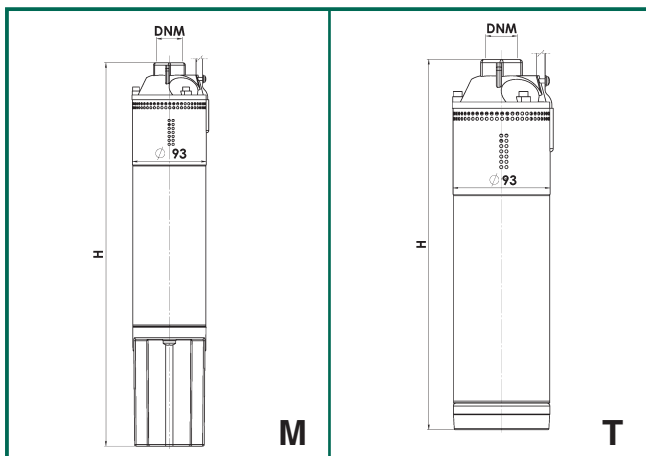

MODEL	Ø	H	DNM	PACK DIMENSIONS (mm)			VOLUME m ³	GROSS WEIGHT Kg
				L/A	L/B	H		
IDEA 75 M	93	482	1" G	630	265	125	0,0208	10,5
IDEA 100 M	93	512	1" G	630	265	125	0,0208	12
IDEA 75 T	93	353	1" G	420	310	118	0,0153	10,2
IDEA 100 T	93	383	1" G	420	310	118	0,0153	11,7

MODEL	ELECTRICAL DATA						HYDRAULIC DATA (n ~ 2800 1/min)									
	INPUT VOLTAGE 50 Hz	P1 MAX kW	P2 NOMINAL		In A	CAPACITOR µF Vc	Q m ³ /h l/min	H (m)								
			kW	HP				0,4	0,6	0,9	1,2	1,5	1,8	2,1	2,4	
IDEA 75 M	1x230 V ~	0,8	0,55	0,75	4	16 450	39	37	32	27,6	22,5	17,6	12,2	6,8		
IDEA 100 M	1x230 V ~	1,1	0,75	1	4,7	20 450	52	48,3	41,4	34,6	28	21,2	14,4	7,3		
IDEA 75 T	3x400 V ~	0,65	0,55	0,75	1,5	- -	39	37	32	27,6	22,5	17,6	12,2	6,8		
IDEA 100 T	3x400 V ~	1,1	0,75	1	2,3	- -	52	48,3	41,4	34,6	28	21,2	14,4	7,3		

CS4



(Control box only for single-phase version)

GENERAL DATA

Applications

Borehole electric pump for 4" wells or larger, capable of generating a broad range of flow rates and heads. These units have a very extensive range of applications for lifting, distribution and pressurisation in civil and industrial water systems, filling of pressure vessels and tanks, fire-fighting and washing installations, and irrigation systems.

Pump construction features

Multistage centrifugal pump with radial or semiaxial impellers. Directly coupled pump and motor with rigid coupling. Technopolymer impellers with stainless steel wear parts, functioning on floating adjustment rings made of synthetic abrasion-proof material with technopolymer diffusers that impart significant wear resistance to the pump. Pump liner and shaft with stainless steel coupling.

Base support (with integral filter) and upper head (with integral resin check valve) made of technopolymer. Plastic cable sheath.

The pumps comply with European Council Directives.

Motor construction characteristics

Submerged asynchronous two-pole motor made of AISI 304 stainless steel. For the parts in contact with the water. Squirrel cage rotor mounted on self-centring thrust block designed to withstand significant axial loads. Cooling of the thrust bearing and the bushings is provided by water, thereby eliminating the risk of oil contamination. Canned-type stator in an airtight casing made of stainless steel AISI 304L.

Capacitor and manually resettable overload protection located in panel supplied as standard for the single-phase version.

Overload protection to be provided by the user for the three-phase version.

Flanging to NEMA – 4"

Protection rating: IP 68

Heat insulation class: F

Input voltage: single phase 220-230 V / 50Hz
three-phase 400 V / 50Hz

Supply

Three-phase CS4 submersible electric pumps are supplied in a kit composed of pump and motor.

The single-phase kit includes pump, motor and control box

TECHNICAL DATA

No.	PART*	MATERIAL
3	BASE SUPPORT	TECHNOPOLYMER A
4	IMPELLER	TECHNOPOLYMER A with adjustment rings in AISI 304 STAINLESS STEEL X5CrNi1810 - UNI 6900/71
6	DIFFUSER	TECHNOPOLYMER A
7	SHAFT WITH COUPLING	AISI 304 STAINLESS STEEL X5CrNi1810 - UNI 6900/71
18	IMPELLERS LOCKING NUT	ACCIAIO INOX
39	CABLE SHEATH	STAINLESS STEEL
49	VALVE	PLASTIC
54	MOTOR	AISI 304 STAINLESS STEEL X5CrNi1810 - UNI 6900/71
55	SPACER	TECHNOPOLYMER A
57	SUPPORT	TECHNOPOLYMER A
69	PUMP LINER	AISI 304 STAINLESS STEEL X5CrNi1810 - UNI 6900/71
98	DIFFUSER BODY	TECHNOPOLYMER A
117	HEAD	TECHNOPOLYMER A
191	FRONT THRUST RING	SYNTHETIC ABRASION-PROOF MATERIAL
192	REAR THRUST RING	SYNTHETIC ABRASION-PROOF MATERIAL
270	UPPER SHAFT GUIDE BUSH	RUBBER

* In contact with liquid.

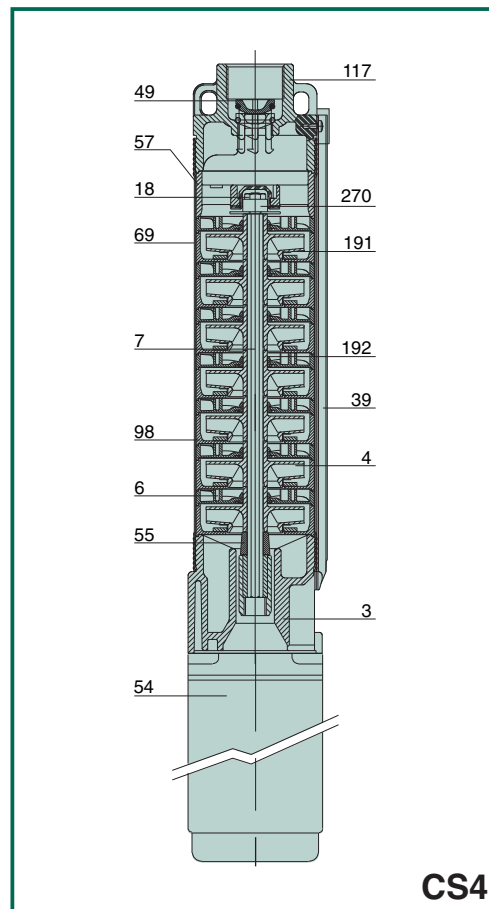

- Operating range: from 0.24 to 6 m³/h with head of up to 230 m.
- Liquid quality requirements: clean, free of solid or abrasive contaminants, non-viscous, non-aggressive, not crystallised and chemically neutral, close to the properties of water.
- Liquid temperature range: from 0°C to +40°C
- Installation: in 4" wells or larger, tanks and cisterns, vertical position.
- N° starts / hour: 20 max
- Cooling flow: 8 cm/sec.
- **Maximum permissible sand quantity: 120 gr/m³**
- Special executions on request: alternative voltages and/or frequencies.
- Power cable and safety rope nylon, standard:
 - length 15 metres: CS4A-8 / CS4A-12 / CS4B-5 / CS4B-8 / CS4B-12 / CS4C-6 / CS4C-9 / CS4D-4 / CS4D-6 / CS4D-8
 - length 30 metres: CS4A-18 / CS4A-25 / CS4A-36 / CS4B-16 / CS4B-24 / CS4C-13 / CS4C-19 / CS4D-13
- Accessories: see page 32-33.
- Power cable cross section: see page 33.
- For the single-phase version, the HS CONTROL BOX can be supplied on request to obtain increased starting torque.

The performance curves are based on kinematic viscosity values = 1 mm²/s and density equivalent to 1000 kg/m³. Tolerance of curves to ISO 9906.

CS4A

Liquid temperature range: from 0°C to +40°C

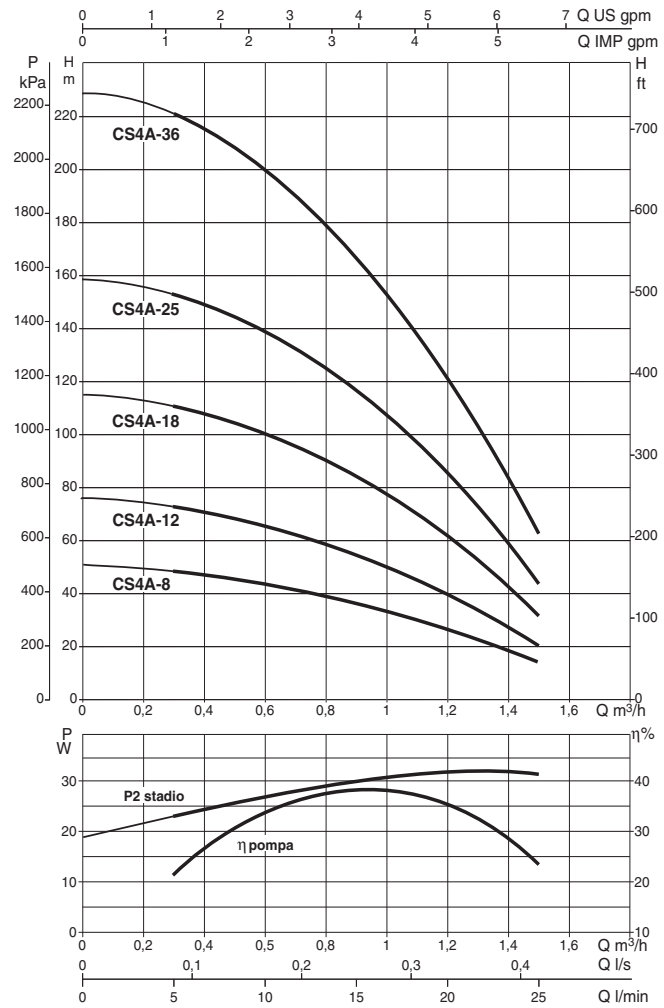
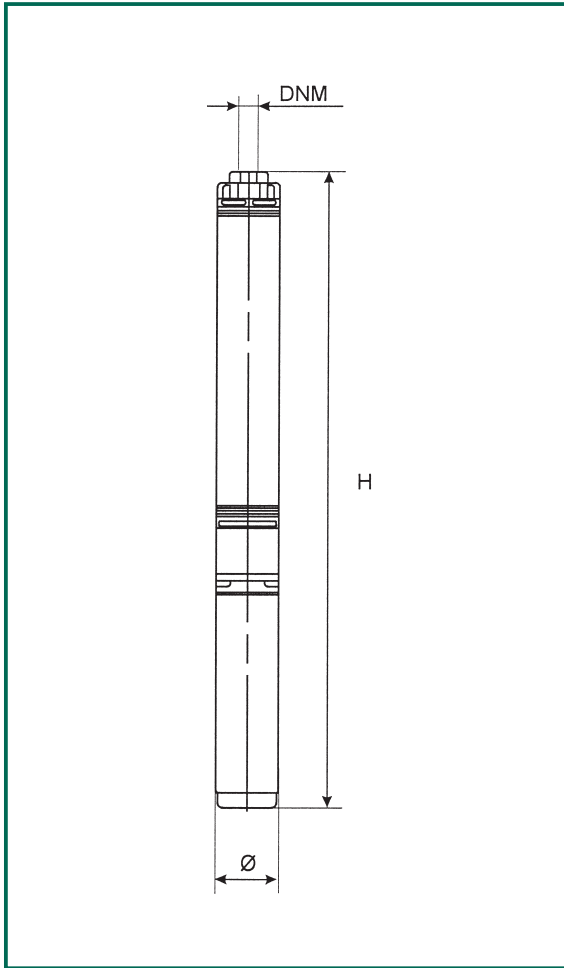

MODEL	Ø (mm)	H (mm)	DNM	PACK DIMENSIONS (mm)			VOLUME m ³	GROSS WEIGHT Kg
				L/A	L/B	H		
CS4A-8 M	97	571	1" 1/4 G	815	90	250	0,018	13,2
CS4A-12 M	97	671	1" 1/4 G	815	90	250	0,018	14,7
CS4A-12 T	97	650	1" 1/4 G	815	90	250	0,018	12,7
CS4A-18 M	97	820	1" 1/4 G	945	90	250	0,021	19,8
CS4A-18 T	97	791	1" 1/4 G	945	90	250	0,021	17,5
CS4A-25 M	97	981	1" 1/4 G	1145	90	250	0,026	22
CS4A-25 T	97	960	1" 1/4 G	1145	90	250	0,026	19,8
CS4A-36 M	97	1307	1" 1/4 G	1375	90	250	0,030	26,3
CS4A-36 T	97	1233	1" 1/4 G	1375	90	250	0,030	22,6

MODEL	ELECTRICAL DATA			HYDRAULIC DATA (n = 2850 1/min)						
	POWER SUPPLY 50 Hz	P2 NOMINAL		Q m ³ /h l/min	0	0,3	0,6	0,9	1,2	1,5
		kW	HP							
CS4A-8 M	1x230 V ~	0,37	0,5	H (m)	51	48,6	44,4	37,3	26,8	13,7
CS4A-12 M	1x230 V ~	0,37	0,5		76,5	72,9	66,6	55,9	40,2	20,5
CS4A-12 T	3x400 V ~*	0,37	0,5		76,5	72,9	66,6	55,9	40,2	20,5
CS4A-18 M	1x230 V ~	0,55	0,75		114,8	109,3	99,8	84	60,3	30,8
CS4A-18 T	3x400 V ~*	0,55	0,75		114,8	109,3	99,8	84	60,3	30,8
CS4A-25 M	1x230 V ~	0,75	1		159,4	151,8	138,7	116,5	83,7	42,7
CS4A-25 T	3x400 V ~*	0,75	1		159,4	151,8	138,7	116,5	83,7	42,7
CS4A-36 M	1x230 V ~	1,1	1,5		229,5	218,6	200	167,8	120,6	61,6
CS4A-36 T	3x400 V ~*	1,1	1,5		229,5	218,6	200	167,8	120,6	61,6

* 3x230 V ~ fornibile su richiesta.

The performance curves are based on kinematic viscosity values = 1 mm²/s and density equivalent to 1000 kg/m³. Tolerance of curves to ISO 9906.

CS4B

Liquid temperature range: from 0°C to +40°C

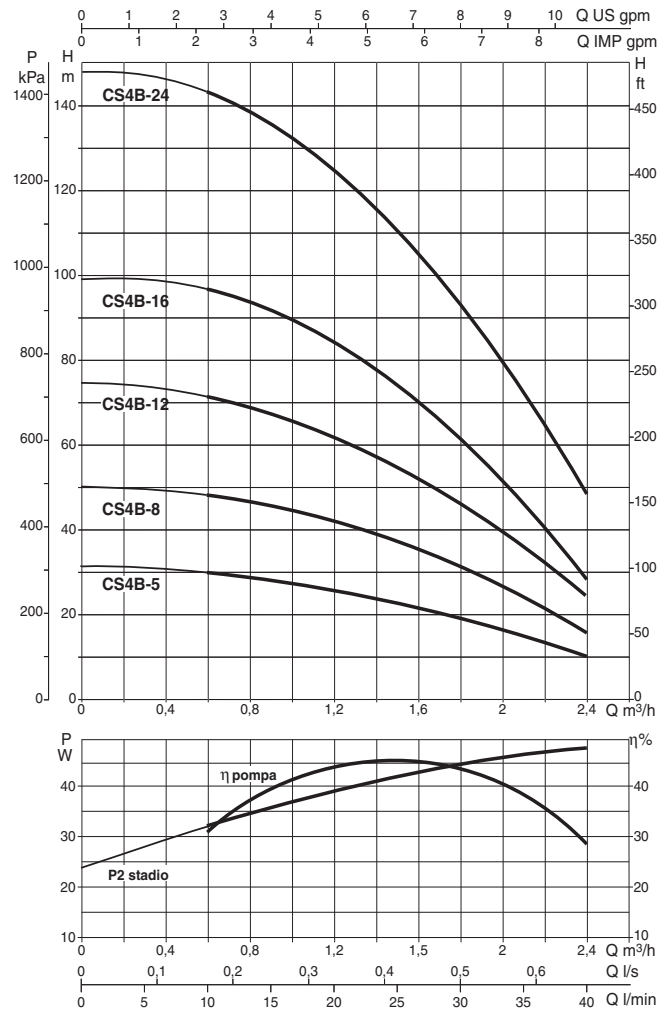
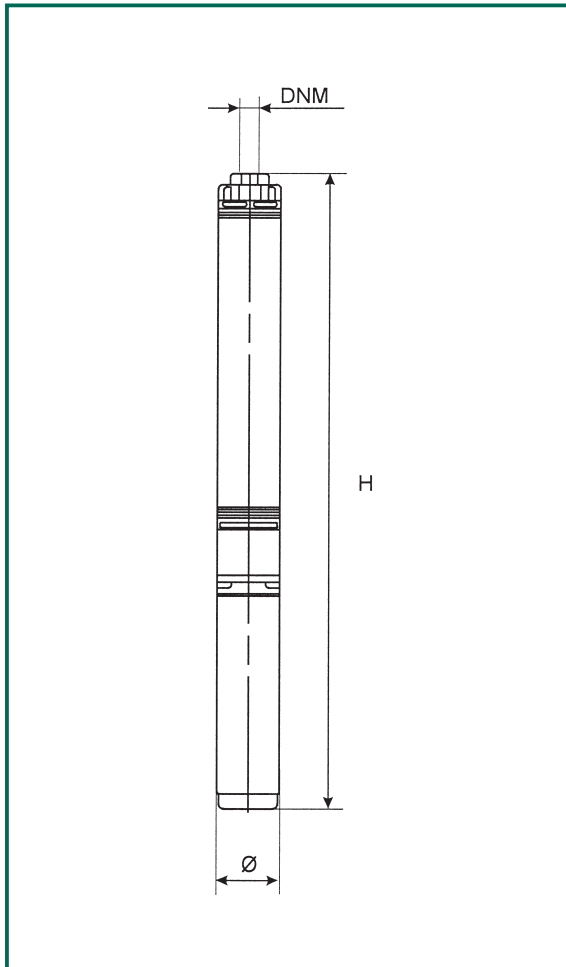

MODEL	Ø (mm)	H (mm)	DNM	PACK DIMENSIONS (mm)			VOLUME m ³	GROSS WEIGHT Kg
				L/A	L/B	H		
CS4B-5 M	97	524	1" 1/4 G	815	90	250	0,018	12,9
CS4B-8 M	97	611	1" 1/4 G	815	90	250	0,018	14,3
CS4B-8 T	97	590	1" 1/4 G	815	90	250	0,018	12,3
CS4B-12 M	97	730	1" 1/4 G	815	90	250	0,018	16,1
CS4B-12 T	97	701	1" 1/4 G	815	90	250	0,018	13,8
CS4B-16 M	97	841	1" 1/4 G	945	90	250	0,021	21
CS4B-16 T	97	820	1" 1/4 G	945	90	250	0,021	18,8
CS4B-24 M	97	1094	1" 1/4 G	1375	90	250	0,030	25
CS4B-24 T	97	1021	1" 1/4 G	1145	90	250	0,026	21,1

MODEL	ELECTRICAL DATA			HYDRAULIC DATA (n = 2850 1/min)								
	POWER SUPPLY 50 Hz	P2 NOMINAL		Q m ³ /h l/min	0	0,6	0,9	1,2	1,5	1,8	2,1	2,4
		kW	HP									
CS4B-5 M	1x230 V ~	0,37	0,5	H (m)	31	30	28,6	26	22,6	19	14,8	10
CS4B-8 M	1x230 V ~	0,37	0,5		49,6	47,8	45,8	41,5	36,2	30,6	23,7	16
CS4B-8 T	3x400 V ~*	0,37	0,5		49,6	47,8	45,8	41,5	36,2	30,6	23,7	16
CS4B-12 M	1x230 V ~	0,55	0,75		74,4	71,8	68,6	62,3	54,4	45,8	35,5	24
CS4B-12 T	3x400 V ~*	0,55	0,75		74,4	71,8	68,6	62,3	54,4	45,8	35,5	24
CS4B-16 M	1x230 V ~	0,75	1		99,2	95,7	91,5	83	72,5	61	47,4	32
CS4B-16 T	3x400 V ~*	0,75	1		99,2	95,7	91,5	83	72,5	61	47,4	32
CS4B-24 M	1x230 V ~	1,1	1,5		148,8	143,5	137,3	124,6	108,7	91,7	71	48
CS4B-24 T	3x400 V ~*	1,1	1,5		148,8	143,5	137,3	124,6	108,7	91,7	71	48

* 3x230 V - fornibile su richiesta.

The performance curves are based on kinematic viscosity values = 1 mm²/s and density equivalent to 1000 kg/m³. Tolerance of curves to ISO 9906.

CS4C

Liquid temperature range: from 0°C to +40°C

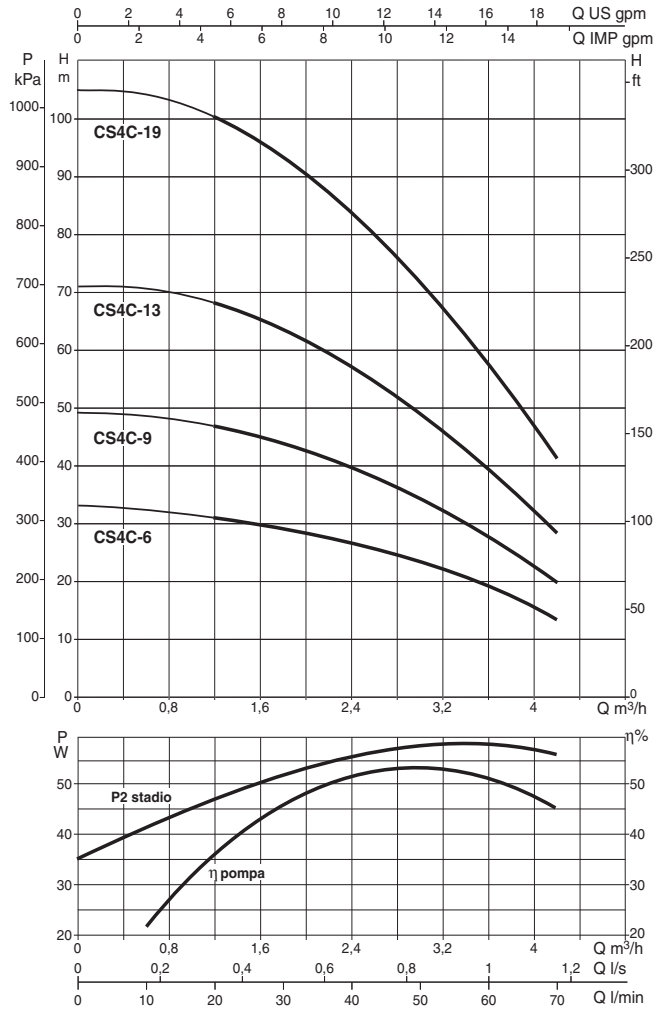
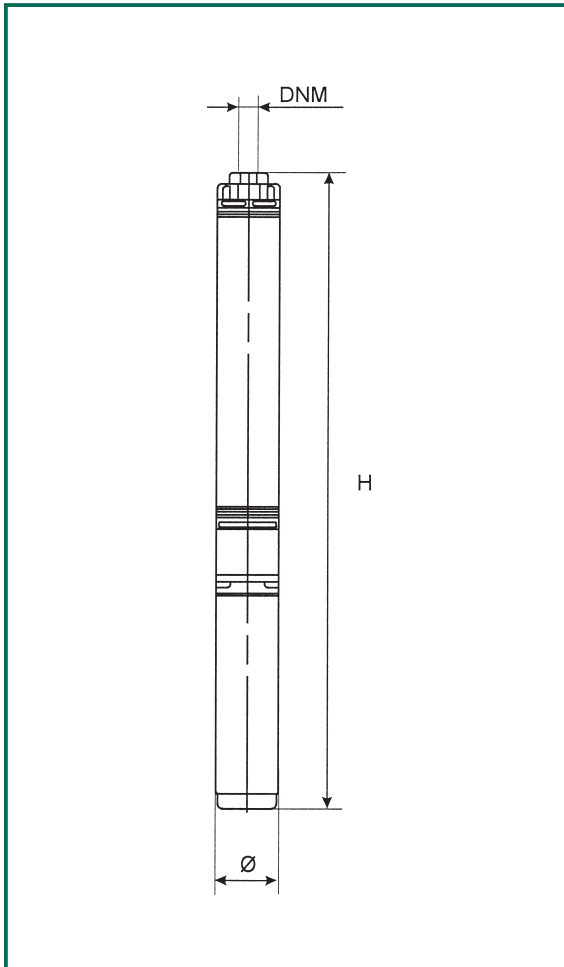

MODEL	Ø (mm)	H (mm)	DNM	PACK DIMENSIONS (mm)			VOLUME m ³	GROSS WEIGHT Kg
				L/A	L/B	H		
CS4C-6 M	97	626	1" 1/4 G	815	90	250	0,018	14,3
CS4C-6 T	97	605	1" 1/4 G	815	90	250	0,018	12,3
CS4C-9 M	97	753	1" 1/4 G	945	90	250	0,021	16,2
CS4C-9 T	97	723	1" 1/4 G	815	90	250	0,018	13,8
CS4C-13 M	97	903	1" 1/4 G	1145	90	250	0,026	21,3
CS4C-13 T	97	883	1" 1/4 G	1145	90	250	0,026	19,1
CS4 C-19 M	97	1172	1" 1/4 G	1375	90	250	0,030	25,3
CS4C-19 T	97	1098	1" 1/4 G	1375	90	250	0,030	21,6

MODEL	ELECTRICAL DATA				HYDRAULIC DATA (n ≈ 2850 1/min)										
	POWER SUPPLY 50 Hz	P2 NOMINAL		P1	Q m³/h l/min	H (m)									
		kW	HP			kW	0	1,2	1,5	1,8	2,1	2,4	3	3,6	4,2
CS4C-6 M	1x230 V ~	0,37	0,5	0,74	H (m)	33	31,8	30,7	29,4	27,5	26,4	22,7	18,5	13,2	
CS4C-6 T	3x400 V ~*	0,37	0,5	0,74		33	31,8	30,7	29,4	27,5	26,4	22,7	18,5	13,2	
CS4C-9 M	1x230 V ~	0,55	0,75	1		49,5	47,7	46	44	41,5	39,6	34	27,5	19,8	
CS4C-9 T	3x400 V ~*	0,55	0,75	1		49,5	47,7	46	44	41,5	39,6	34	27,5	19,8	
CS4C-13 M	1x230 V ~	0,75	1	1,3		71,5	68,9	66,4	63,7	60,5	57,2	49,2	40	28,6	
CS4C-13 T	3x400 V ~*	0,75	1	1,3		71,5	68,9	66,4	63,7	60,5	57,2	49,2	40	28,6	
CS4 C-19 M	1x230 V ~	1,1	1,5	1,8		104,5	100,7	97	93	87,8	83,6	71,8	58,5	41,8	
CS4C-19 T	3x400 V ~*	1,1	1,5	1,8		104,5	100,7	97	93	87,8	83,6	71,8	58,5	41,8	

* 3x230 V ~ available on request.

The performance curves are based on kinematic viscosity values = 1 mm²/s and density equivalent to 1000 kg/m³. Tolerance of curves to ISO 9906.

CS4D

Liquid temperature range: from 0°C to +40°C

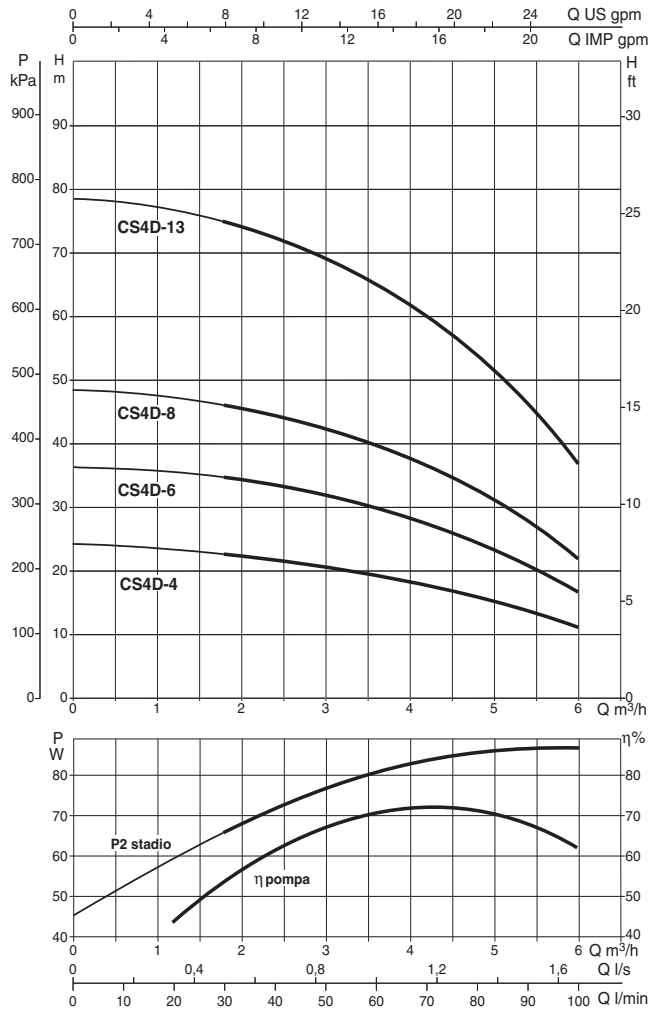
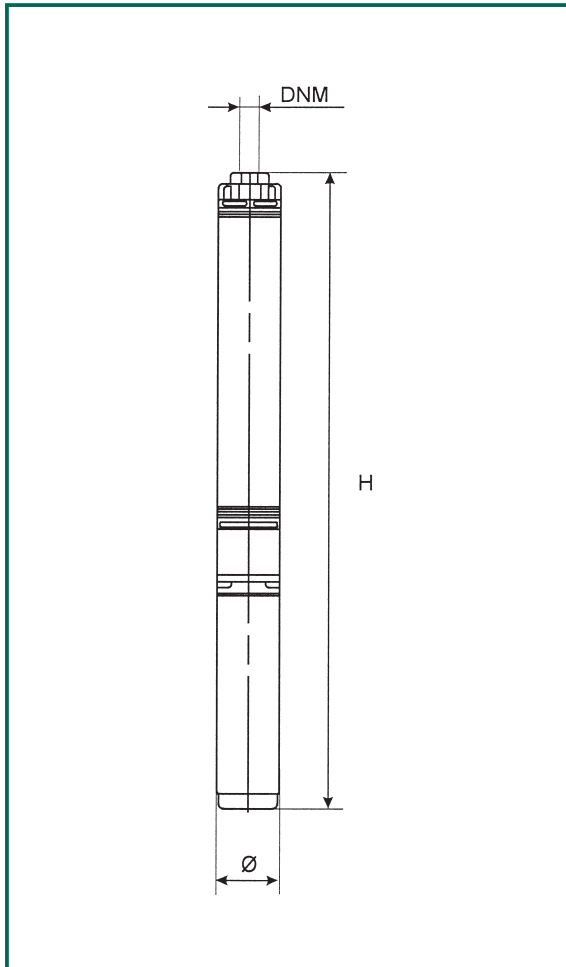

MODEL	Ø (mm)	H (mm)	DNM	PACK DIMENSIONS (mm)			VOLUME m ³	GROSS WEIGHT Kg
				L/A	L/B	H		
CS4D-4 M	97	561	1" 1/4 G	815	90	250	0,018	14
CS4D-4 T	97	540	1" 1/4 G	815	90	250	0,018	12
CS4D-6 M	97	655	1" 1/4 G	815	90	250	0,018	15,6
CS4D-6 T	97	626	1" 1/4 G	815	90	250	0,018	13,3
CS4D-8 M	97	741	1" 1/4 G	945	90	250	0,021	17,3
CS4D-8 T	97	720	1" 1/4 G	815	90	250	0,018	15
CS4D-13 M	97	977	1" 1/4 G	1145	90	250	0,026	24,1
CS4D-13 T	97	903	1" 1/4 G	1145	90	250	0,026	20,4

MODEL	ELECTRICAL DATA			HYDRAULIC DATA (n ≈ 2850 1/min)										
	POWER SUPPLY 50 Hz	P2 NOMINAL		P1 kW	Q m³/h	H (m)								
		kW	HP			0	1,8	2,1	2,4	3	3,6	4,2	4,8	6
CS4D-4 M	1x230 V ~	0,37	0,5	0,74	0	24	23	22,5	22	21,8	19,9	18	16,2	11,2
CS4D-4 T	3x400 V ~*	0,37	0,5	0,74	0	24	23	22,5	22	21,8	19,9	18	16,2	11,2
CS4D-6 M	1x230 V ~	0,55	0,75	1	0,4	36	34,5	33,7	33	31,5	29,8	27	24,3	16,8
CS4D-6 T	3x400 V ~*	0,55	0,75	1	0,8	36	34,5	33,7	33	31,5	29,8	27	24,3	16,8
CS4D-8 M	1x230 V ~	0,75	1	1,3	0,8	48	46	45	44	42	40	36	32,5	22,4
CS4D-8 T	3x400 V ~*	0,75	1	1,3	1,2	48	46	45	44	42	40	36	32,5	22,4
CS4D-13 M	1x230 V ~	1,1	1,5	1,8	1,6	78	74,7	73,2	71,5	68,3	64,6	59	52,6	36,4
CS4D-13 T	3x400 V ~*	1,1	1,5	1,8	1,6	78	74,7	73,2	71,5	68,3	64,6	59	52,6	36,4

* 3x230 V - available on request.

S4



SAND
RESISTANT



(Control box only for single-phase version)

GENERAL DATA

Applications

Submerged electric pump for 4" wells or larger, capable of generating a broad range of flow rates and heads. These units have a very extensive range of applications for lifting, distribution and pressurisation in civil and industrial water systems, filling of pressure vessels and tanks, fire-fighting and washing installations, and irrigation systems.

Pump construction features

Multistage centrifugal type with radial or semiaxial impellers. Directly coupled pump and motor with rigid coupling. Technopolymer impellers with stainless steel wear parts, functioning on floating clearance rings made of synthetic low abrasion material with technopolymer diffusers that impart significant wear resistance to the pump. Pump liner, shaft and coupling, filter and cable cover in stainless steel.

Base support and head in microcast AISI 304 stainless steel with steel check valve incorporated in head. The pumps comply with European Council Directives.

Motor construction characteristics

Submerged asynchronous two-pole motor made of AISI 304 stainless steel. For the parts in contact with the water. Squirrel cage rotor mounted on self-centring thrust block designed to withstand significant axial loads. Cooling of the thrust bearing and the bushings is provided by water, thereby eliminating the risk of oil contamination. Canned-type stator in an airtight casing made of stainless steel AISI 304L.

Flanging to NEMA – 4"

Protection rating: IP68

Heat insulation class: F

Input voltage: single phase 220-230 V / 50Hz
three-phase 400 V / 50Hz

Supply

Control box (for single phase version) and motor must be ordered separately.

TECHNICAL DATA

No.	PART*	MATERIAL
3	BASE SUPPORT	MICROCAST IN AISI 304 STEEL
4	IMPELLER	TECHNOPOLYMER A with adjustment rings in AISI 304 STAINLESS STEEL X5CrNi1810 – UNI 6900/71
6	DIFFUSER	TECHNOPOLYMER A
7	SHAFT WITH COUPLING	AISI 304 STAINLESS STEEL X5CrNi1810 – UNI 6900/71
18	IMPELLERS LOCKING NUT	STAINLESS STEEL
39	CABLE SHEATH	AISI 304 STAINLESS STEEL X5CrNi1810 – UNI 6900/71
42	STRAINER	STAINLESS STEEL
49	VALVE	AISI 304 STAINLESS STEEL X5CrNi1810 – UNI 6900/71
54	MOTOR	AISI 304 STAINLESS STEEL X5CrNi1810 – UNI 6900/71
55	SPACER	TECHNOPOLYMER A
57	SUPPORT	TECHNOPOLYMER A
58	INTERMEDIATE BUSH	AISI 304 STAINLESS STEEL X5CrNi1810 – UNI 6900/71
69	PUMP LINER	AISI 304 STAINLESS STEEL X5CrNi1810 – UNI 6900/71
98	DIFFUSER BODY	TECHNOPOLYMER A
117	HEAD	MICROCAST IN AISI 304 STEEL
191	FRONT THRUST RING	SYNTHETIC ABRASION-PROOF MATERIAL
192	REAR THRUST RING	SYNTHETIC ABRASION-PROOF MATERIAL
270	TOP SHAFT GUIDE BUSH	RUBBER
271	INTERMEDIATE SHAFT GUIDE BUSH	SYNTHETIC ABRASION-PROOF MATERIAL

* In contact with liquid.

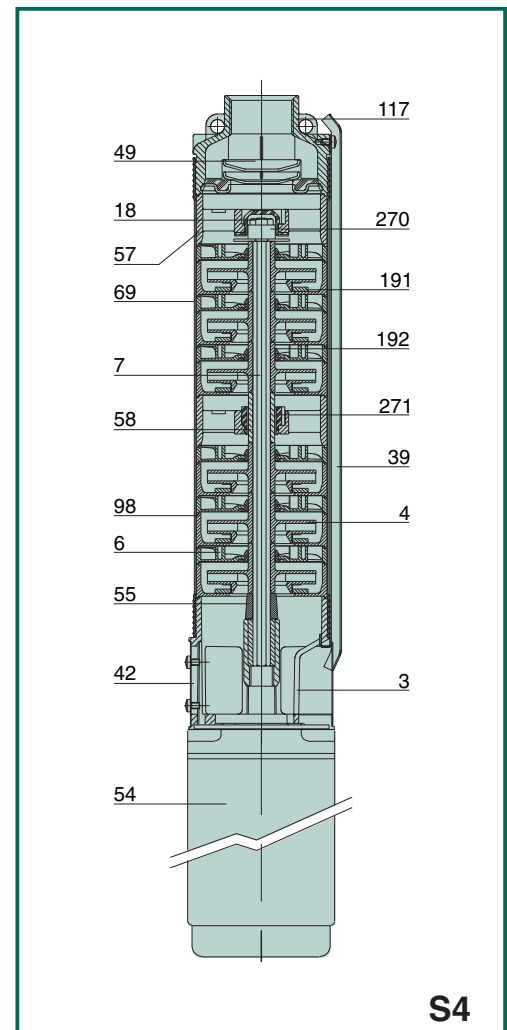

- Operating range: from 0.3 to 24 m³/h with head of up to 320 m.
- Liquid quality requirements: clean, free of solid or abrasive contaminants, chemically neutral, close to the properties of water.
- Liquid temperature range: from 0°C to +40°C
- **Maximum permissible sand quantity:** 120 gr/m³
- Installation: in 4" wells or larger, tanks and cisterns, vertical position.
- N° starts / hour: 20 max.
- Cooling flow: 8 cm/sec.
- Special executions on request: alternative voltages and/or frequencies
- Accessories: see pages 32-33.
- Power cable cross section: see table on page 33.
- For the single-phase version the HS CONTROL BOX can be supplied on request to obtained increased starting torque.

The performance curves are based on kinematic viscosity values = 1 mm²/s and density equivalent to 1000 kg/m³. Tolerance of curves to ISO 9906.

S4A

Liquid temperature range: from 0°C to +40°C

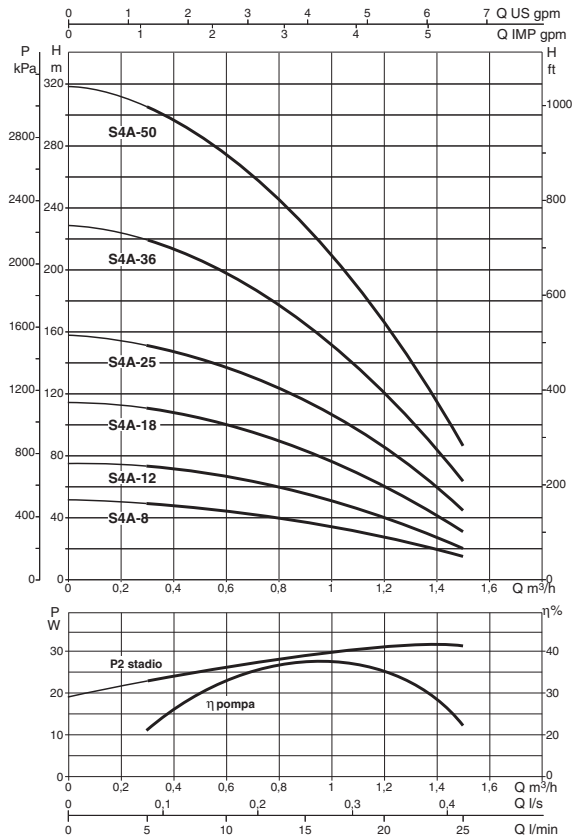
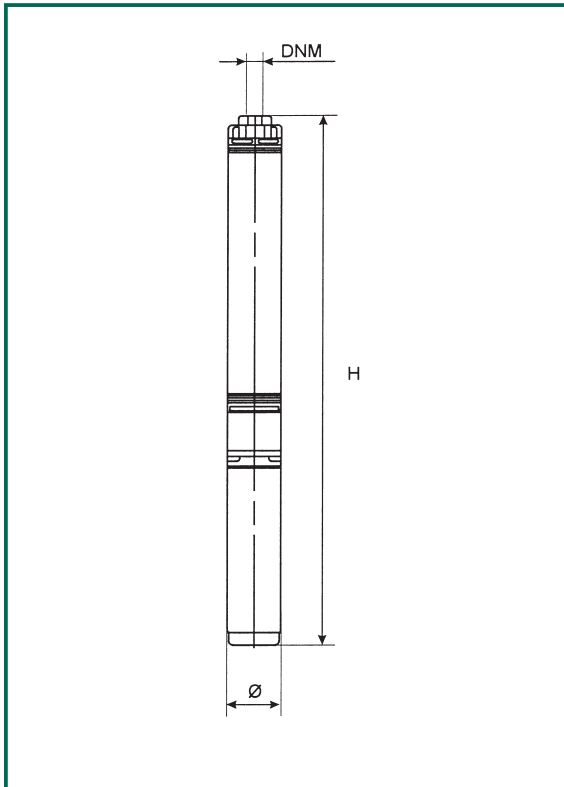

MODEL	Ø (mm)	HEIGHT H		DNM	PACK DIMENSIONS (mm)			VOLUME m ³	GROSS WEIGHT Kg	
		M single-phase	T three-phase		L/A	L/B	H		M single-phase	T three-phase
S4A-8 M	97	559	–	1" 1/4 G	110	110	770	0,010	11,4	–
S4A-12 M / S4A-12 T	97	659	638	1" 1/4 G	110	110	770	0,010	13	12
S4A-18 M / S4A-18 T	97	808	779	1" 1/4 G	110	110	910	0,011	15,2	13,9
S4A-25 M / S4A-25 T	97	969	948	1" 1/4 G	110	110	1080	0,013	16	16,2
S4A-36 M / S4A-36 T	97	1295	1221	1" 1/4 G	120	120	1590	0,023	21,9	19,2
S4A-50 M / S4A-50 T	97	1636	1563	1" 1/4 G	120	120	1920	0,028	24,8	22,5

MODEL	ELECTRICAL DATA			HYDRAULIC DATA (n = 2850 1/min)						
	POWER SUPPLY 50 Hz	P2 NOMINAL		Q m³/h l/min	0	0,3	0,6	0,9	1,2	1,5
		kW	HP							
S4A-8 M	1x230 V ~	0,37	0,5	H (m)	51	48,6	44,4	37,3	26,8	13,7
S4A-12 M	1x230 V ~	0,37	0,5		76,5	72,9	66,6	55,9	40,2	20,5
S4A-12 T	3x400 V ~*	0,37	0,5		76,5	72,9	66,6	55,9	40,2	20,5
S4A-18 M	1x230 V ~	0,55	0,75		114,8	109,3	99,8	84	60,3	30,8
S4A-18 T	3x400 V ~*	0,55	0,75		114,8	109,3	99,8	84	60,3	30,8
S4A-25 M	1x230 V ~	0,75	1		159,4	151,8	138,7	116,5	83,7	42,7
S4A-25 T	3x400 V ~*	0,75	1		159,4	151,8	138,7	116,5	83,7	42,7
S4A-36 M	1x230 V ~	1,1	1,5		229,5	218,6	200	167,8	120,6	61,6
S4A-36 T	3x400 V ~*	1,1	1,5		229,5	218,6	200	167,8	120,6	61,6
S4A-50 M	1x230 V ~	1,5	2		318,8	303,7	277,4	233,1	167,5	85,5
S4A-50 T	3x400 V ~*	1,5	2		318,8	303,7	277,4	233,1	167,5	85,5

* 3x230 V ~ available on request.

The performance curves are based on kinematic viscosity values = 1 mm²/s and density equivalent to 1000 kg/m³. Tolerance of curves to ISO 9906.

S4B

Liquid temperature range: from 0°C to +40°C

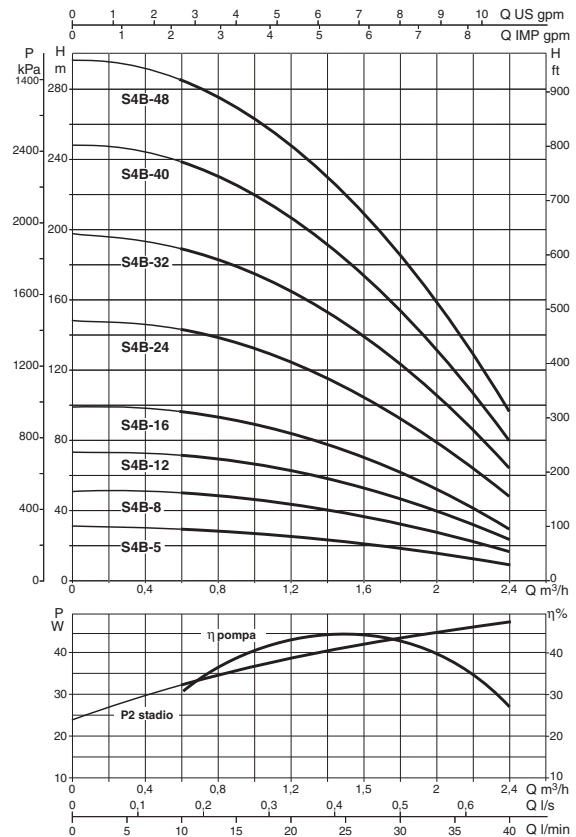
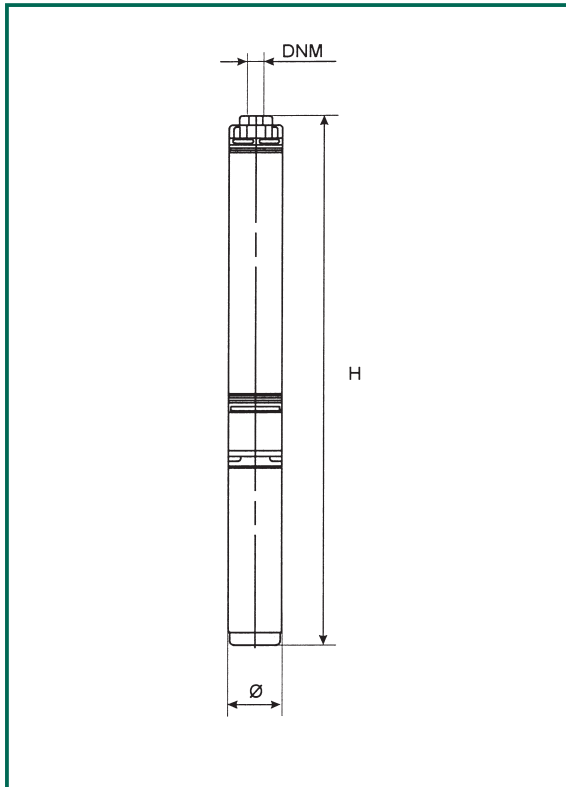

MODEL	Ø (mm)	HEIGHT H		DNM	PACK DIMENSIONS (mm)			VOLUME (M/T) m ³	GROSS WEIGHT Kg	
		M single-phase	T three-phase		L/A	L/B	H (M/T)		M single-phase	T three-phase
S4B-5 M	97	512	-	1" 1/4 G	110	110	770	0,010	11,1	-
S4B-8 M / S4B-8 T	97	599	578	1" 1/4 G	110	110	770	0,010	12,5	11,5
S4B-12 M / S4B-12 T	97	718	689	1" 1/4 G	110	110	770	0,010	14,4	12
S4B-16 M / S4B-16 T	97	829	808	1" 1/4 G	110	110	1080/910	0,013/0,010	16,3	15,1
S4B-24 M / S4B-24 T	97	1082	1009	1" 1/4 G	120	120	1240	0,018	20,2	17,5
S4B-32 M / S4B-32 T	97	1324	1251	1" 1/4 G	120	120	1590/1330	0,023/0,019	22,5	20,2
S4B-40 M / S4B-40 T	97	1528	1508	1" 1/4 G	120	120	1920/1590	0,028/0,023	27,6	22,9
S4B-48 M / S4B-48 T	97	1708	1688	1" 1/4 G	120	120	1920	0,028	28,7	24,2

MODEL	ELECTRICAL DATA				HYDRAULIC DATA (n ≈ 2850 1/min)																																																																																																																							
	POWER SUPPLY 50 Hz	P2 NOMINAL		Q m³/h	0	0,6	0,9	1,2	1,5	1,8	2,1	2,4	H (m)	0		10		15		20		25		30		35		40																																																																																																
		kW	HP											0	10	15	20	25	30	35	40	0	10	15	20	25	30	35	40																																																																																															
S4B-5 M ⁽¹⁾	1x230 V ~	0,37	0,5	H (m)	31	30	28,6	26	22,6	19	14,8	10	49,6	47,8	45,8	41,5	36,2	30,6	23,7	16	49,6	47,8	45,8	41,5	36,2	30,6	23,7	16	74,4	71,8	68,6	62,3	54,4	45,8	35,5	24	74,4	71,8	68,6	62,3	54,4	45,8	35,5	24	99,2	95,7	91,5	83	72,5	61	47,4	32	99,2	95,7	91,5	83	72,5	61	47,4	32	148,8	143,5	137,3	124,6	108,7	91,7	71	48	148,8	143,5	137,3	124,6	108,7	91,7	71	48	198,4	191,4	183	166	144,9	122,2	94,7	64	198,4	191,4	183	166	144,9	122,2	94,7	64	248	239,2	228,8	207,6	181,2	152,8	118,4	80	248	239,2	228,8	207,6	181,2	152,8	118,4	80	297,6	287,1	274,6	249,2	217,4	183,4	142,1	96	297,6	287,1	274,6	249,2	217,4	183,4	142,1	96

* 3x230 V ~ available on request.

The performance curves are based on kinematic viscosity values = 1 mm²/s and density equivalent to 1000 kg/m³. Tolerance of curves to ISO 9906.

S4C

Liquid temperature range: from 0°C to +40°C

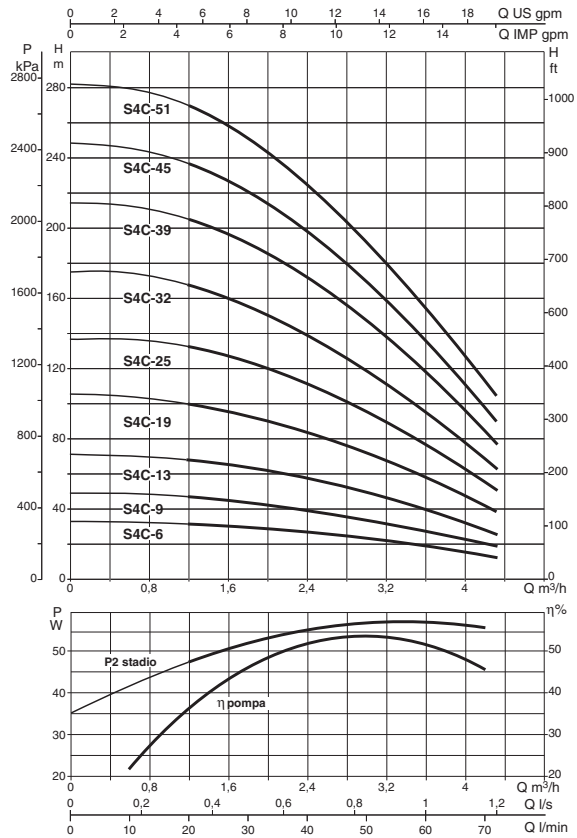
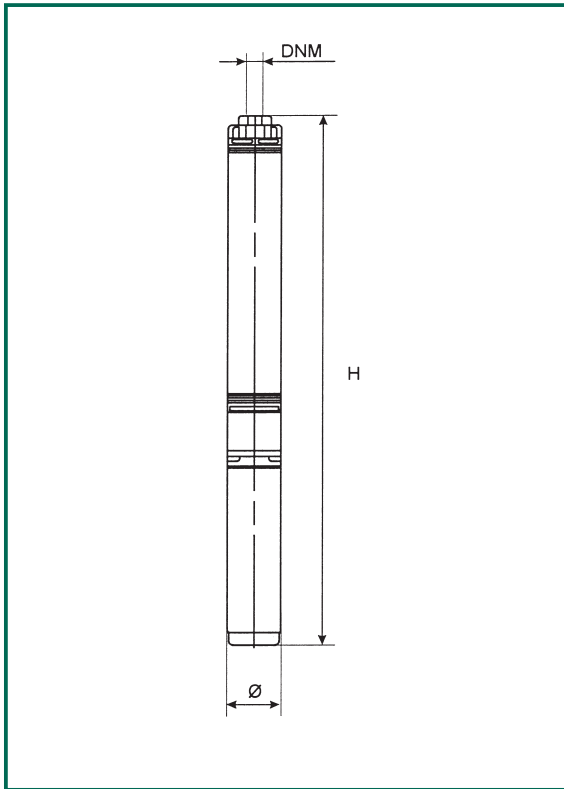

MODEL	Ø (mm)	HEIGHT H		DNM	PACK DIMENSIONS (mm)			VOLUME m ³	GROSS WEIGHT Kg	
		M single-phase	T three-phase		L/A	L/B	H		M single-phase	T three-phase
S4C-6 M / S4C-6 T	97	614	593	1" 1/4 G	110	110	770	0,010	12,6	11,5
S4C-9 M / S4C-9 T	97	741	711	1" 1/4 G	110	110	910	0,011	14,6	13,2
S4C-13 M / S4C-13 T	97	891	871	1" 1/4 G	110	110	1080	0,013	15,5	15,4
S4C-19 M / S4C-19 T	97	1160	1086	1" 1/4 G	120	120	1240	0,018	18,5	17,8
S4C-25 M / S4C-25 T	97	1416	1343	1" 1/4 G	120	120	1590	0,023	25,2	20,5
S4C-32 M / S4C-32 T	97	1668	1648	1" 1/4 G	120	120	1920	0,028	28,2	23,7
S4C-39 M / S4C-39 T	97	1896	1875	1" 1/4 G	120	120	2200	0,032	29,8	25,3
S4C-45 T	97	-	2337	1" 1/4 G	120	120	2600	0,038	-	34
S4C-51 T	97	-	2532	1" 1/4 G	120	120	2600	0,038	-	32,6

MODEL	ELECTRICAL DATA			HYDRAULIC DATA (n ≈ 2850 1/min)									
	POWER SUPPLY 50 Hz	P2 NOMINAL		Q m³/h l/min	0	1,2	1,5	1,8	2,1	2,4	3	3,6	4,2
		kW HP			0	20	25	30	35	40	50	60	70
S4C-6 M	1x230 V ~	0,37	0,5	H (m)	33	31,8	30,7	29,4	27,5	26,4	22,7	18,5	13,2
S4C-6 T	3x400 V ~*	0,37	0,5		33	31,8	30,7	29,4	27,5	26,4	22,7	18,5	13,2
S4C-9 M	1x230 V ~	0,55	0,75		49,5	47,7	46	44	41,5	39,6	34	27,7	19,8
S4C-9 T	3x400 V ~*	0,55	0,75		49,5	47,7	46	44	41,5	39,6	34	27,7	19,8
S4C-13 M	1x230 V ~	0,75	1		71,5	68,9	66,4	63,7	60,5	57,2	49,2	40	28,6
S4C-13 T	3x400 V ~*	0,75	1		71,5	68,9	66,4	63,7	60,5	57,2	49,2	40	28,6
S4C-19 M	1x230 V ~	1,1	1,5		104,5	100,7	97	93	87,8	83,6	71,8	58,5	41,8
S4C-19 T	3x400 V ~*	1,1	1,5		104,5	100,7	97	93	87,8	83,6	71,8	58,5	41,8
S4C-25 M	1x230 V ~	1,5	2		137,5	132,5	128	122,5	116	110	94,5	77	55
S4C-25 T	3x400 V ~*	1,5	2		137,5	132,5	128	122,5	116	110	94,5	77	55
S4C-32 M	1x230 V ~	2,2	3		176	169,6	163	156,8	149	140,8	120,9	98,6	70,4
S4C-32 T	3x400 V ~*	2,2	3		176	169,6	163	156,8	149	140,8	120,9	98,6	70,4
S4C-39 M	1x230 V ~	2,2	3		214,5	206,7	200	191,1	181,5	171,6	147,4	120,1	85,8
S4C-39 T	3x400 V ~*	2,2	3		214,5	206,7	200	191,1	181,5	171,6	147,4	120,1	85,8
S4C-45 T	3x400 V ~*	3	4		247,5	238,5	229	220,5	210	198	170,1	138,6	99
S4C-51 T	3x400 V ~*	3	4		280,5	270,3	261	250	237	224,4	192,8	157,1	112,2

* 3x230 V ~ available on request.

The performance curves are based on kinematic viscosity values = 1 mm²/s and density equivalent to 1000 kg/m³. Tolerance of curves to ISO 9906.

S4D

Liquid temperature range: from 0°C to +40°C

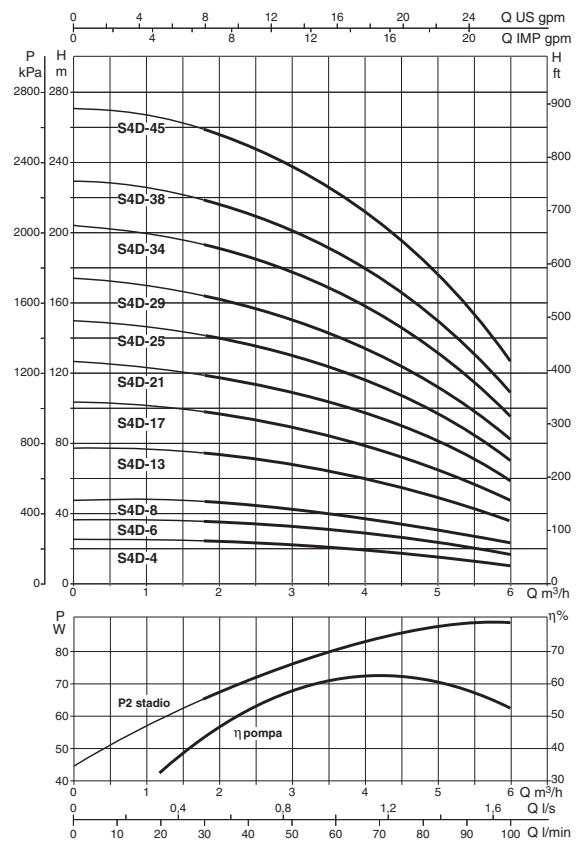
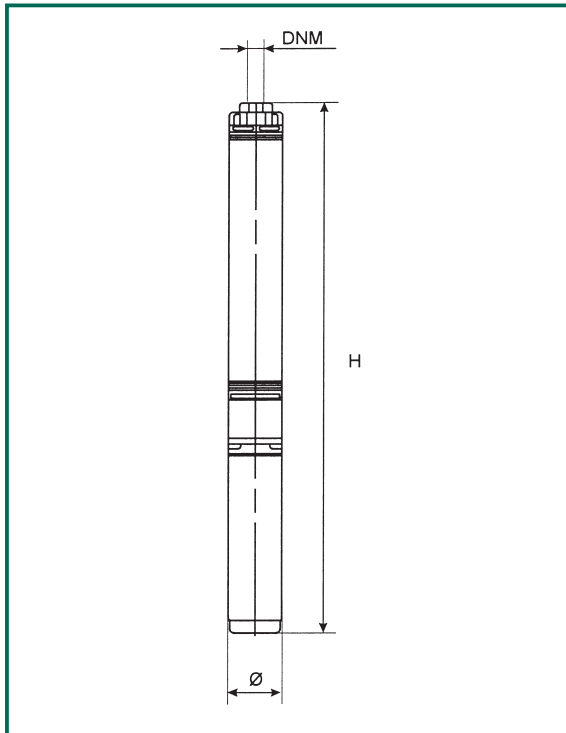

MODEL	Ø (mm)	HEIGHT H		DNM	PACK DIMENSIONS (mm)			VOLUME (M/T) m ³	GROSS WEIGHT Kg	
		M single-phase	T three-phase		L/A	L/B	H (M/T)		M single-phase	T three-phase
S4D-4 M / S4D-4 T	97	549	528	1" 1/4 G	110	110	770	0,010	12,2	11,2
S4D-6 M / S4D-6 T	97	643	614	1" 1/4 G	110	110	770	0,010	14	12,7
S4D-8 M / S4D-8 T	97	729	708	1" 1/4 G	110	110	910	0,011	15,5	14,3
S4D-13 M / S4D-13 T	97	965	891	1" 1/4 G	110	110	1080	0,013	17	16,6
S4D-17 M / S4D-17 T	97	1156	1083	1" 1/4 G	120	120	1240	0,018	19,5	18,8
S4D-21 M / S4D-21 T	97	1278	1258	1" 1/4 G	120	120	1590/1330	0,023/0,018	25,7	20,1
S4D-25 M / S4D-25 T	97	1408	1388	1" 1/4 G	120	120	1590	0,023	26,5	22
S4D-29 T	97	-	1785	1" 1/4 G	120	120	1820	0,028	-	25,7
S4D-34 T	97	-	1947	1" 1/4 G	120	120	2200	0,032	-	27
S4D-38 T	97	-	2096	1" 1/4 G	120	120	2200	0,032	-	33,7
S4D-45 T	97	-	2324	1" 1/4 G	120	120	2600	0,038	-	35,3

MODEL	ELECTRICAL DATA			HYDRAULIC DATA (n = 2850 1/min)										
	POWER SUPPLY 50 Hz	P2 NOMINAL		Q m³/h	H (m)									
		kW	HP		0	1,8	2,1	2,4	3	3,6	4,2	4,8	6	
S4D-4 M	1x230 V ~	0,37	0,5	24	23	22,5	22	21,8	19,9	18	16,2	11,2		
S4D-4 T	3x400 V ~*	0,37	0,5	24	23	22,5	22	21,8	19,9	18	16,2	11,2		
S4D-6 M	1x230 V ~	0,55	0,75	36	34,5	33,7	33	31,5	29,8	27	24,3	16,8		
S4D-6 T	3x400 V ~*	0,55	0,75	36	34,5	33,7	33	31,5	29,8	27	24,3	16,8		
S4D-8 M	1x230 V ~	0,75	1	48	46	45	44	42	40	36	32,5	22,4		
S4D-8 T	3x400 V ~*	0,75	1	48	46	45	44	42	40	36	32,5	22,4		
S4D-13 M	1x230 V ~	1,1	1,5	78	74,7	73,2	71,5	68,3	64,6	59	52,6	36,4		
S4D-13 T	3x400 V ~*	1,1	1,5	78	74,7	73,2	71,5	68,3	64,6	59	52,6	36,4		
S4D-17 M	1x230 V ~	1,5	2	102	98	96	93,5	89,5	84,5	77,5	68,8	47,6		
S4D-17 T	3x400 V ~*	1,5	2	102	98	96	93,5	89,5	84,5	77,5	68,8	47,6		
S4D-21 M	1x230 V ~	2,2	3	126	121	119	115,5	110	104,4	96	85	58,8		
S4D-21 T	3x400 V ~*	2,2	3	126	121	119	115,5	110	104,4	96	85	58,8		
S4D-25 M	1x230 V ~	2,2	3	150	144	141	137,5	132	124,2	114,5	101,2	70		
S4D-25 T	3x400 V ~*	2,2	3	150	144	141	137,5	132	124,2	114,5	101,2	70		
S4D-29 T	3x400 V ~*	3	4	174	166	164	159,5	152	144	132	117,4	81,2		
S4D-34 T	3x400 V ~*	3	4	204	196	191,5	187	179,5	169	155	137,7	95,2		
S4D-38 T	3x400 V ~*	4	5,5	228	219	214,5	209	200	188,9	173	153,9	106,4		
S4D-45 T	3x400 V ~*	4	5,5	270	259	253	247,5	237	223,6	205	182,2	127		

* 3x230 V - available on request.

The performance curves are based on kinematic viscosity values = 1 mm²/s and density equivalent to 1000 kg/m³. Tolerance of curves to ISO 9906.

S4E

Liquid temperature range: from 0°C to +40°C

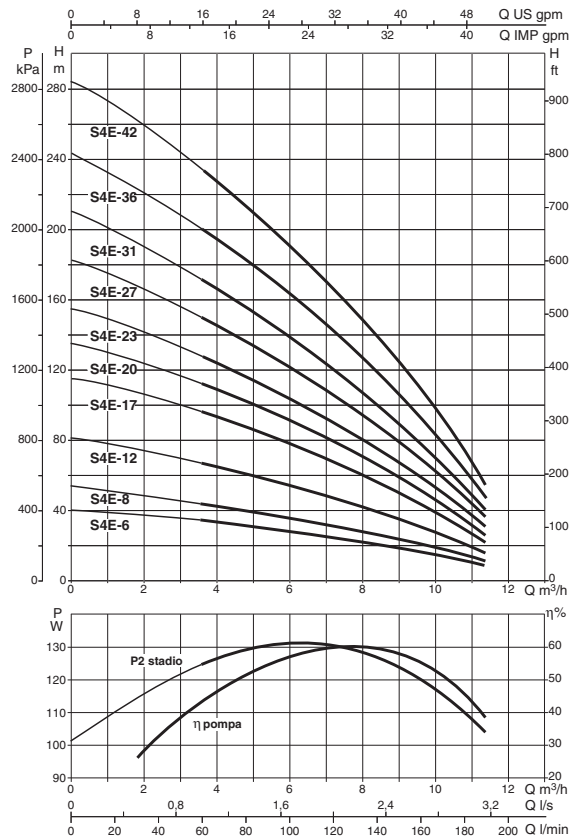
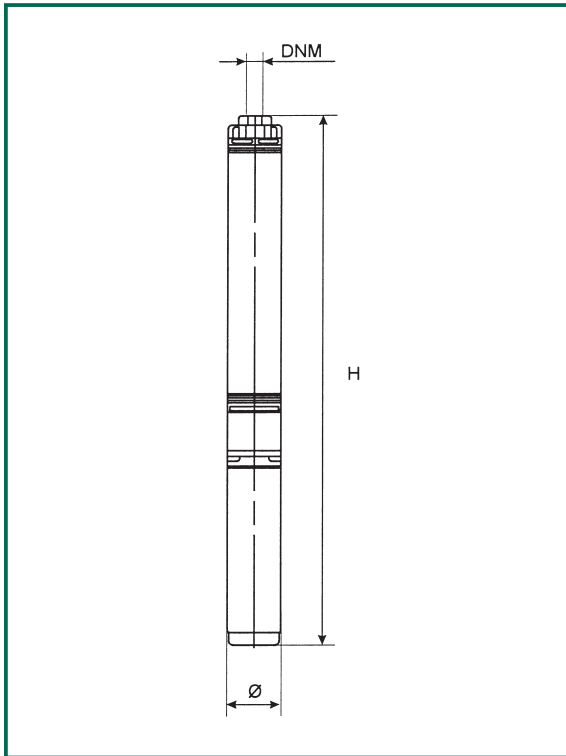

MODEL	Ø (mm)	HEIGHT H		DNM	PACK DIMENSIONS (mm)			VOLUME (M/T) m ³	GROSS WEIGHT Kg	
		M single-phase	T three-phase		L/A	L/B	H (M/T)		M single-phase	T three-phase
S4E-6 M / S4E-6 T	97	786	765	2" G-F	110	110	910	0,011	15,9	14,7
S4E-8 M / S4E-8 T	97	964	891	2" G-F	110	110	1080	0,013	17	16,4
S4E-12 M / S4E-12 T	97	1236	1163	2" G-F	120	120	1330/1240	0,019/0,018	21,6	19
S4E-17 M / S4E-17 T	97	1523	1502	2" G-F	120	120	1920/1590	0,028/0,023	27	23,5
S4E-20 T	97	-	1894	2" G-F	120	120	1920	0,028	-	25,8
S4E-23 T	97	-	2052	2" G-F	120	120	2200	0,032	-	27
S4E-27 T	97	-	2281	2" G-F	120	120	2600	0,038	-	34,4
S4E-31 T	97	-	2491	2" G-F	120	120	2600	0,038	-	35,5
S4E-36 T	97	-	2855	2" G-F	180	180	3000	0,097	-	43
S4E-42 T	97	-	3170	2" G-F	180	180	3300	0,097	-	44,8

MODEL	ELECTRICAL DATA				HYDRAULIC DATA (n ≈ 2850 1/min)									
	POWER SUPPLY 50 Hz	P2 NOMINAL		Q m³/h	H (m)									
		kW			HP		0	3,6	4,2	4,8	6	7,2	9	10,8
S4E-6 M	1x230 V ~	0,75	1	40,5	32,7	31,5	30	27	23,5	17,6	10,3	7,7		
S4E-6 T	3x400 V ~*	0,75	1	40,5	32,7	31,5	30	27	23,5	17,6	10,3	7,7		
S4E-8 M	1x230 V ~	1,1	1,5	54	43,7	42	40	37	31,4	23,4	13,7	10,3		
S4E-8 T	3x400 V ~*	1,1	1,5	54	43,7	42	40	37	31,4	23,4	13,7	10,3		
S4E-12 M	1x230 V ~	1,5	2	81	65,5	63	60	55	47	35,2	20,6	15,5		
S4E-12 T	3x400 V ~*	1,5	2	81	65,5	63	60	55	47	35,2	20,6	15,5		
S4E-17 M	1x230 V ~	2,2	3	114,8	92,8	89,5	86	78	66,6	49,8	29,2	21,9		
S4E-17 T	3x400 V ~*	2,2	3	114,8	92,8	89,5	86	78	66,6	49,8	29,2	21,9		
S4E-20 T	3x400 V ~*	3	4	135	109,2	105	101,5	91	78,4	58,6	34,3	25,7		
S4E-23 T	3x400 V ~*	3	4	155,4	125,5	120,5	117	104,5	90,2	67,4	40	29,6		
S4E-27 T	3x400 V ~*	4	5,5	182,4	147,4	141,5	137	122,5	105,8	79,2	47	34,8		
S4E-31 T	3x400 V ~*	4	5,5	209,4	169,2	162	156	140	121,5	90,9	53,2	39,9		
S4E-36 T	3x400 V ~*	5,5	7,5	243,2	196,5	188	180	162	141,2	105,5	61,8	46,5		
S4E-42 T	3x400 V ~*	5,5	7,5	283,7	229,3	220	211	189	164,7	123,2	72,2	54		

* 3x230 V ~ available on request.

The performance curves are based on kinematic viscosity values = 1 mm²/s and density equivalent to 1000 kg/m³. Tolerance of curves to ISO 9906.

S4F

Liquid temperature range: from 0°C to +40°C

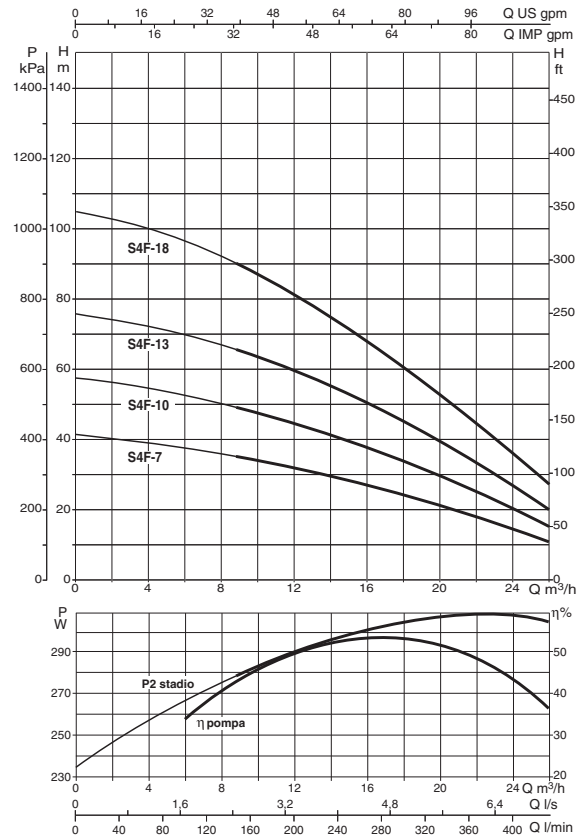
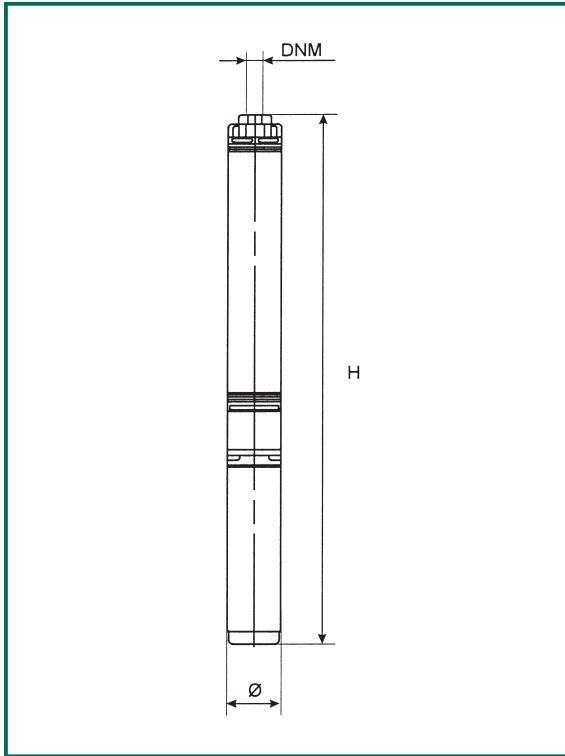

MODEL	Ø (mm)	HEIGHT H		DNM	PACK DIMENSIONS (mm)			VOLUME m ³	GROSS WEIGHT Kg	
		M single-phase	T three-phase		L/A	L/B	H		M single-phase	T three-phase
S4F-7 M / S4F-7 T	97	1073	1079	2" G-F	120	120	1240	0,018	24,4	18,5
S4F-10 T	97	–	1491	2" G-F	120	120	1590	0,023	–	23,5
S4F-13 T	97	–	1715	2" G-F	120	120	1920	0,032	–	31,2
S4F-18 T	97	–	2156	2" G-F	120	120	2600	0,038	–	50,5

MODEL	ELECTRICAL DATA			HYDRAULIC DATA (n ≈ 2850 1/min)								
	POWER SUPPLY 50 Hz	P2 NOMINAL		Q m ³ /h	0	9	10,8	11,4	12	15	18	27
		kW	HP	l/min	0	150	180	190	200	250	300	450
S4F-7 M	1x230 V ~	2,2	3	H (m)	40,5	36	34	33	32,5	28	24	11
S4F-7 T	3x400 V ~*	2,2	3		40,5	36	34	33	32,5	28	24	11
S4F-10 T	3x400 V ~*	3	4		58	50,8	48	47	46	40	34	16
S4F-13 T	3x400 V ~*	4	5,5		76	66	62,5	62	60	52,2	44,7	20
S4F-18 T	3x400 V ~*	5,5	7,5		104,5	91	86,6	84	83	72	61,2	28

* 3x230 V ~ available on request.

SUBMERGED MOTOR 4" series 4GG



Submerged asynchronous two-pole motor made of AISI 304 stainless steel for parts in contact with water. Cooling of the thrust bearing and the bushings is provided by a mixture of water and glycol. Rotor mounted on Kingsbury self-centring thrust block. Stator housed in an airtight stainless steel casing. Flanging to NEMA 4". Protection rating IP 68. Heat insulation class F. Removable connector. Vertical / horizontal operation (ensure a minimum load is applied to the thrust block). Maximum working depth: 300 m. Motor suitable for use with variable frequency drive (30Hz-50Hz). Capacitor and manually resettable overload protection located in electrical panel that can be supplied separately for the single-phase version. Overload protection to be provided by the user for the three-phase version.

Motor construction characteristics

STATOR. Canned-type stator in an airtight casing made of AISI 304L stainless steel. Insulation class F. Compatible with up to 20 starts per hour.

POWER CABLE. All motors are supplied as standard with a removable 4-core cable to allow easy and rapid disassembly/assembly of the motor or part of the pump without any risk of damaging the cable.

SUPPORTS. Upper and lower supports are made of G20 cast iron with Teflon coating, equipped with carbon-graphite bushes. Support covers in AISI 304 stainless steel.

THRUST BEARINGS SYSTEM

Kingsbury type thrust bearings with lapped shoes in stainless steel.

The special design and machining process ensure high reliability and long life. Thrust bearing systems vary in compliance with different installed power values:

from 0.5 hp to 1.5 hp: class 2000 N

from 2 hp to 3 hp: class 3000 N

from 4 hp to 10 hp: class 6000 N

ROTOR SHAFT series 2000N - 3000N - 6000N. Rotor shaft extension in stainless steel.

The rotor is made of die cast aluminium up to 3 Hp and in copper for all motors from 4 hp up to 10 hp.

CONTROL BOX. Electrical control box for operation of single-phase motors, containing manually resettable overload protection, capacitor, and terminals for electrical connections and connection of pressure switches/float switches if required.

Complete with 1.5 m cable with SCHUKO plug CEE 7- UNEL 47166-168. Wall-mounting box in self-extinguishing plastic.

MODEL		Power input 50 Hz V	In A	Ist A	P1 Max W	Rpm N	cosφ ?	Eff. ?	Capac. μF	Axial thrust N	Length mm	Weight Kg	CABLE	
Hp	KW												Cross section mm²	Length m
0,5	0,37	1 ~ 230 V	3,3	9	740	2820	0,97	50	16	2000	236	6,7	4 x 1,5	1,7
0,75	0,55	1 ~ 230 V	4,6	15	1000	2820	0,94	56	20	2000	266	8	4 x 1,5	1,7
1	0,75	1 ~ 230 V	6,2	20	1300	2820	0,92	58	25	2000	286	9	4 x 1,5	1,7
1,5	1,1	1 ~ 230 V	8,6	31	1820	2830	0,92	62	35	2000	331	11	4 x 1,5	1,7
2	1,5	1 ~ 230 V	11	41	2320	2820	0,91	65	40	3000	393	13	4 x 1,5	1,7
3	2,2	1 ~ 230 V	16	50	3460	2820	0,94	65	60	3000	413	13,8	4 x 1,5	1,7
5	3,7	1 ~ 230 V	25	90	5500	2850	0,95	65	90	6000	684	26,5	4 x 2	2,7
0,5	0,37	3 ~ 230 V	2,7	10	710	2820	0,7	53	-	2000	216	6	4 x 1,5	1,7
		3 ~ 400 V	1,6	6										
0,75	0,55	3 ~ 230 V	3,3	14	920	2830	0,71	60	-	2000	236	6,7	4 x 1,5	1,7
		3 ~ 400 V	1,9	8										
1	0,75	3 ~ 230 V	4,1	21	1190	2830	0,73	63	-	2000	266	8	4 x 1,5	1,7
		3 ~ 400 V	2,4	12										
1,5	1,1	3 ~ 230 V	5,7	24	1720	2830	0,76	64	-	2000	286	9	4 x 1,5	1,7
		3 ~ 400 V	3,4	14										
2	1,5	3 ~ 230 V	7,6	33	2200	2830	0,72	68	-	3000	348	11	4 x 1,5	1,7
		3 ~ 400 V	4,4	19										
3	2,2	3 ~ 230 V	10,2	45	3170	2820	0,78	71	-	3000	393	13	4 x 1,5	1,7
		3 ~ 400 V	5,9	26										
4	3	3 ~ 230 V	14,3	66	4050	2840	0,71	74	-	6000	544	19,7	4 x 1,5	2,7
		3 ~ 400 V	8,3	38										
5,5	4	3 ~ 230 V	17,3	97	5340	2850	0,79	75	-	6000	614	23	4 x 2	2,7
		3 ~ 400 V	10	56									4 x 1,5	
7,5	5,5	3 ~ 230 V	24,2	133	7110	2850	0,74	77	-	6000	684	26,6	4 x 2	2,7
		3 ~ 400 V	14	77									4 x 1,5	
10	7,5	3 ~ 400 V	17,4	84	9520	2850	0,79	79	-	6000	764	30,6	4 x 2	3,5

COMPONENT	MATERIAL	TYPE
Internal sleeve and outer casing	Stainless steel	AISI 304 L
Shaft extension	Stainless steel	AISI 304 /Duplex
Upper support	Teflon coated cast iron	
Support cover	Stainless steel	AISI 304
Lip seal	Rubber	NBR
Gaskets	Rubber	NBR
Lower cover	Stainless steel	AISI 304
Lower support	Teflon coated cast iron	
Bellow seal	Rubber	EPDM
Thrust bearings	Steel-Graphite	
Valve	Stainless steel	AISI 304
Cable	Rubber	EPDM
Connector plug	Stainless steel	AISI 316
Sand guard (fixed-mobile)	Rubber	NBR
Screws	Stainless steel	AISI 304
Coolant	Antifreeze+Water	

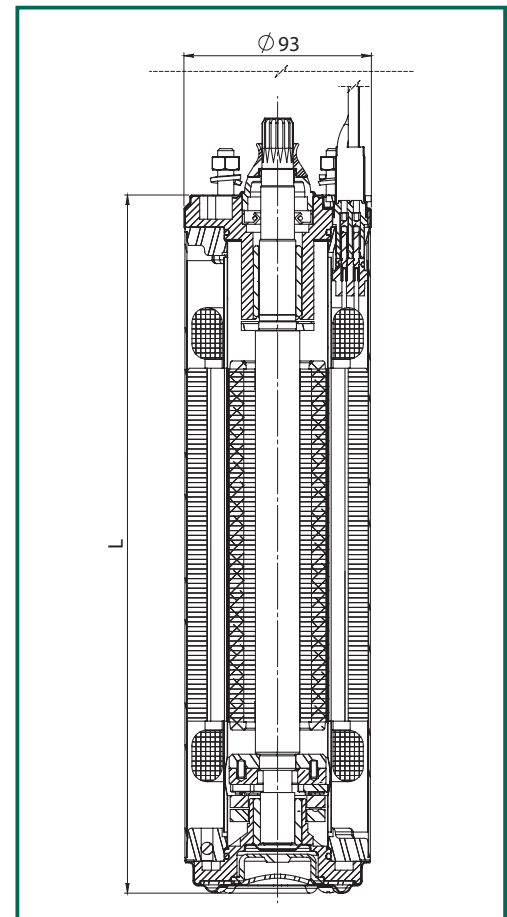

SUBMERGED MOTOR 4" series 4TW



Submerged asynchronous two-pole motor made of AISI 304 stainless steel for parts in contact with water. Cooling of the thrust bearing and the bushings is provided by a mixture of water and glycol. Squirrel cage rotor in copper mounted on Kingsbury self-centring thrust block. Stator housed in an airtight stainless steel casing. Flanging to NEMA 4". Protection rating IP 68. Heat insulation class F. Removable connector. Vertical/horizontal operation (ensure a minimum load is applied to the thrust bearing assembly). Maximum working depth: 300 m. Motor suitable for use with variable frequency drive (30Hz-50Hz). The motor is complete with a start capacitor and does not require the use of the control box.

Motor construction characteristics

STATOR. Canned-type stator in an airtight casing made of AISI 304L stainless steel. Insulation class F. Can be subjected to up to 20 starts/hour and is equipped, in all versions, with a thermal cut-out that protects the motor in the event of overloads/anomalous running conditions.

POWER CABLE. All motors are supplied as standard with a removable 3-core cable to allow easy and rapid disassembly/assembly of the motor or part of the pump without any risk of damaging the cable.

SUPPORTS. Upper and lower supports are made of G20 cast iron with Teflon coating, equipped with carbon-graphite bushes. Support covers in AISI 304 stainless steel.

THRUST BEARINGS SYSTEM

Kingsbury type thrust bearings with lapped shoes in stainless steel.

The special design and machining process ensure high reliability and long life.

from 0.5 hp to 1.5 hp class 2000 N

ROTOR SHAFT series 2000N. Rotor shaft extension in stainless steel. The rotor is made of die cast aluminium.

CAPACITOR The start capacitor is enclosed in a rugged, high-density plastic enclosure and electrically insulated by means of epoxy resin. The capacitor enclosure is easily replaceable.

P ₂		Power input 50 Hz V	I _n A	I _{st} A	P ₁ Max W	Rpm N	T _n Nm	T _s Nm	cosφ	Eff. ?	Capac. μF	Axial thrust N	Length mm	Peso Kg	CABLE	
Hp	KW														Cross section mm ²	Length m
0,5	0,37	1 ~ 230 V	3,3	9	740	2820	1,2	0,9	0,97	50	16	2000	405	7,3	4 x 1,5	1,7
0,75	0,55	1 ~ 230 V	4,6	15	1000	2820	1,9	1,3	0,94	56	20	2000	435	8,5	4 x 1,5	1,7
1	0,75	1 ~ 230 V	6,2	20	1300	2820	2,5	1,6	0,92	58	25	2000	455	9,3	4 x 1,5	1,7
1,5	1,1	1 ~ 230 V	8,6	31	1820	2830	3,8	2,6	0,92	62	35	2000	500	11,3	4 x 1,5	1,7

COMPONENT	MATERIAL	TYPE
Internal sleeve and outer casing	Stainless steel	AISI 304 L
Shaft extension	Stainless steel	AISI 304
Upper support	Teflon coated cast iron	
Support cover	Stainless steel	AISI 304
Lip seal	Rubber	NBR
Gaskets	Rubber	NBR
Lower support	Teflon coated cast iron	
Bellow seal	Rubber	EPDM
Capacitor enclosure	Plastic	Noryl
Thrust bearings	Steel-Graphite	
Valve	Stainless steel	AISI 304
Cable	Rubber	EPDM
Connector plug	Stainless steel	AISI 316
Sand guard (fixed-mobile)	Rubber	NBR
Screws	Stainless steel	AISI 304
Coolant	Antifreeze+Water	

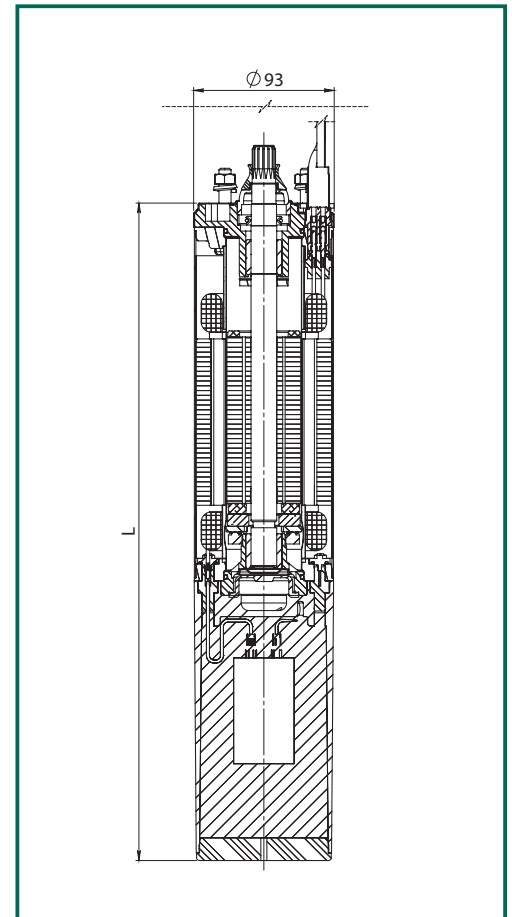

SUBMERGED MOTOR 4" series 40L



Submerged asynchronous two-pole rewindable motor made of AISI 304 stainless steel for parts in contact with water. Cooling and lubrication of ball bearings is assured by a special FDA approved coolant. Rotor mounted on two oversized ball bearings (three bearings for 4HP and higher). Stator housed in a stainless steel casing. Graphite/ceramic mechanical seal. Flanging to NEMA 4". Protection rating IP 68. Heat insulation class F. Removable connector. Vertical/horizontal operation. Maximum working depth: 250 m. Motor suitable for use with variable frequency drive (30Hz-50Hz). Capacitor and manually resettable overload protection located in electrical panel that can be supplied separately for the single-phase version. Overload protection to be provided by the user for the three-phase version.

Motor construction characteristics

STATOR. The rewindable stator is enclosed in an AISI 304L stainless steel jacket. Insulation class F. Compatible with up to 20 starts per hour.

POWER CABLE. All motors are supplied as standard with a removable 4-core cable to allow easy and rapid disassembly/assembly of the motor or part of the pump without any risk of damaging the cable.

SUPPORTS. Upper and lower supports are made of G20 cast iron with protective coating, equipped with carbon-graphite bushes. Support covers in AISI 304 stainless steel.

THRUST BEARINGS SYSTEM

Oversized high axial load ball bearings.

Thrust bearing systems vary in compliance with the various different installed power values:

from 0.5 hp to 2 hp:	class 2000 N
from 3 hp:	class 3000 N
from 4 hp to 5.5 hp:	class 4000 N
from 7.5 hp to 10 hp:	class 5000 N

ROTOR SHAFT Rotor shaft extension in stainless steel. The rotor is made of die cast aluminium up to 3 hp and in copper for all motors from 4 hp up to 10 hp.

CAPACITOR Electrical control box for operation of single-phase motors, containing manually resettable overload protection, capacitor, and terminals for electrical connections and connection of pressure switches/float switches if required.

Complete with 1.5 m cable with SCHUKO plug CEE 7- UNEL 47166-168. Wall-mounting box in self-extinguishing thermoplastic.

MODEL		Power input 50 Hz	In	Ist	P1 Max	Rpm	cosφ	Eff.	Capac.	Axial thrust	Length	Weight	CABLE	
Hp	KW	V	A	A	W	N		?	μF	N	mm	Kg	Cross section mm²	Length m
0,5	0,37	1 ~ 230 V	3,5	9	725	2800	0,90	51	16	2000	325	6,5	4 x 1,5	1,7
0,75	0,55	1 ~ 230 V	4,5	12	950	2800	0,92	58	20	2000	345	7,5	4 x 1,5	1,7
1	0,75	1 ~ 230 V	6,3	20	1275	2820	0,88	59	25	2000	375	8,7	4 x 1,5	1,7
1,5	1,1	1 ~ 230 V	8,5	25	1780	2800	0,91	62	35	2000	395	9,6	4 x 1,5	1,7
2	1,5	1 ~ 230 V	10,8	35	2160	2800	0,87	69	40	2000	440	11,5	4 x 1,5	1,7
3	2,2	1 ~ 230 V	14	45	3060	2800	0,87	78	60	3000	558	15,8	4 x 1,5	1,7
0,5	0,37	3 ~ 230 V	2,8	9	700	2820	0,63	53		2000	325	6,5	4 x 1,5	1,7
		3 ~ 400 V	1,6	5,2										
0,75	0,55	3 ~ 230 V	3,8	13	980	2820	0,64	56	-	2000	325	6,5	4 x 1,5	1,7
		3 ~ 400 V	2,2	7,5										
1	0,75	3 ~ 230 V	4,5	17,3	1200	2820	0,68	62	-	2000	345	7,5	4 x 1,5	1,7
		3 ~ 400 V	2,6	10										
1,5	1,1	3 ~ 230 V	6,2	28	1700	2830	0,68	65	-	2000	375	8,7	4 x 1,5	1,7
		3 ~ 400 V	3,6	16										
2	1,5	3 ~ 230 V	7,9	35	2160	2810	0,68	69	-	2000	395	9,6	4 x 1,5	1,7
		3 ~ 400 V	4,6	20										
3	2,2	3 ~ 230 V	10,9	57	3050	2810	0,70	72	-	3000	498	11,5	4 x 1,5	1,7
		3 ~ 400 V	6,3	33										
4	3	3 ~ 230 V	13,6	78	4000	2840	0,73	75	-	4000	558	17,6	4 x 1,5	2,7
		3 ~ 400 V	7,9	45									4 x 1,5	
5,5	4	3 ~ 230 V	17,6	95	5260	2850	0,74	76	-	4000	628	23	4 x 2	2,7
		3 ~ 400 V	10,2	55									4 x 1,5	
7,5	5,5	3 ~ 230 V	22,6	121	6900	2850	0,76	80	-	5000	698	26,6	4 x 2	2,7
		3 ~ 400 V	13,1	70									4 x 1,5	
10	7,5	3 ~ 400 V	16,9	84	9030	2840	0,77	81	-	5000	778	30,6	4 x 2	3,5

COMPONENT	MATERIAL	TYPE
Internal sleeve and outer casing	Stainless steel	AISI 304 L
Upper support	Nickel-plated cast iron	
Shaft extension	Stainless steel	AISI 304/Duplex
Support cover	Stainless steel	AISI 304
Mechanical seal	Carbon-Ceramic	
Gaskets	Rubber	NBR
Cap	Stainless steel	AISI 304
Bellow seal	Rubber	EPDM
Pins	Stainless steel	AISI 304
Cable	Rubber	EPDM
Connector plug	Stainless steel	AISI 316
Sand guard (fixed-mobile)	Rubber	NBR
Screws	Stainless steel	AISI 304
Coolant	Mineral oil	

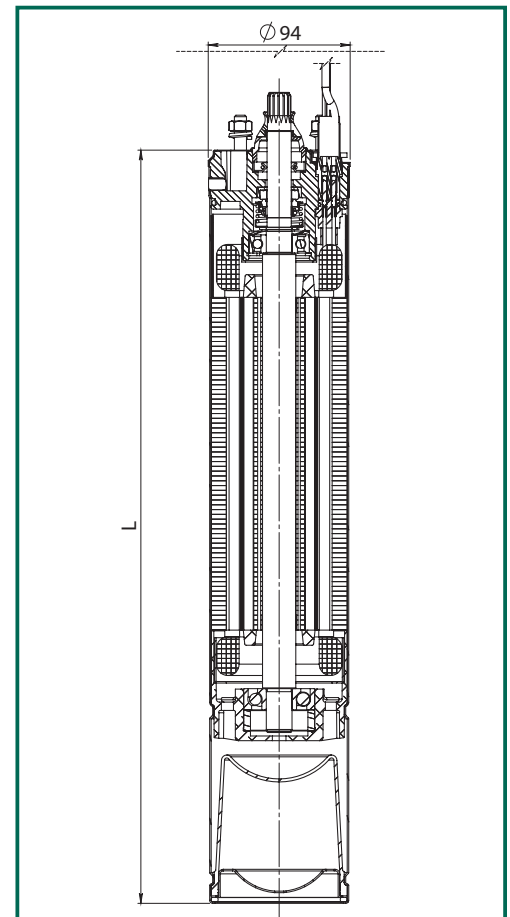

CONTROL AND PROTECTION SYSTEMS

FOR BOREHOLE PUMPS

Control Box

Supplied as standard in CS series

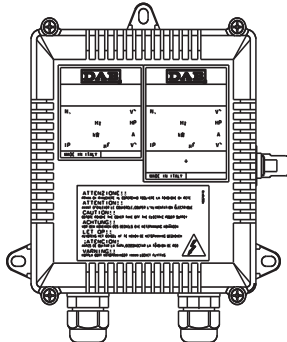

Electrical control box for operation of single-phase electric pumps motors, containing manually resettable overload protection, capacitor, and terminals for electrical connections.

Complete with terminals for connection of a pressure switch / float switch if required. Complete with 1.5 m cable with SCHUKO plug CEE 7- VII UNEL 47166-68. Wall-mounting box in self-extinguishing thermoplastic.

HS control unit

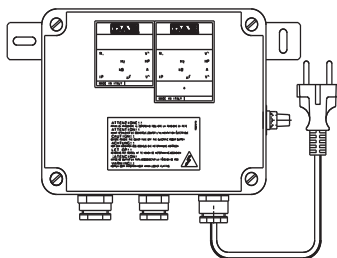

Control unit to increase starting torque of single phase electric pumps with power ratings of 0.5 – 0.75 – 1.5 HP 220V- containing a manually resettable micro cut-out for overload protection, the start capacitor, a capacitor to boost starting torque, and terminals for electrical connections.

Protection rating: IP 55

Ambient operating temperature: -10°C + 40°C

Complete with 1.5 m power cable 3G1.5 H07 VV-F.

Wall-mounting box in self-extinguishing thermoplastic.

MODEL	POWER INPUT 50 HZ	MAX POWER kW	MAX CURRENT A	START CAPAC. µF	STARTING TORQUE BOOST CAPACITOR µF	GROSS WEIGHT kg
Control HS 0.5	1x220 V~	0,37	4	16	20	2,1
Control HS 0.75	1x220 V~	0,55	5	20	30	2,2
Control HS 1	1x220 V~	0,75	6	30	40	2,2
Control HS 1.5	1x220 V~	1,1	10	40	60	2,4

ES 1 M - ES 3 M

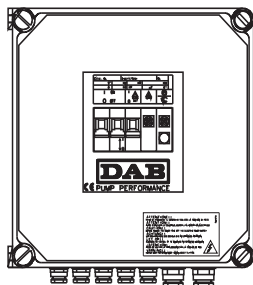

Control box for dry run protection of borehole single-phase electric pumps (see table). The control box is protected and it protects the electric pump from overloads and short circuits, with manual reset facility.

Complete with:

- Terminals for min/max level control (with float switches, pressure switches, etc.)
- Terminals for connection of a remote control
- Pump manual run button
- Timer to control stop time to protect against dry running.
- Protection against excessive number of starts (can be bypassed).
- Terminals (voltage-free) for remote feeding of an audible alarm.

Facility for operation with 1, 2 or 3 sensors, depending on application.

Protection rating IP 55. Operating range: from -10°C to +40°C

Supplied as standard with an electric probe and wall-mounting brackets.

Wall-mounting box in self-extinguishing thermoplastic.

MODEL	POWER INPUT 50-60 HZ	POWER KW P2 MOT.	NOM. DUTY POWER (MAX) (KW)	MAX CURRENT A	DIMENSIONS			GROSS WEIGHT kg
					A	B	H	
ES 1 M	1x220-240 V~	0,25-0,37-0,55-0,75	1,85	10	270	300	190	5,6
ES 3 M	1x220-240 V~	1,1-1,5-2,2	2,2	16	270	300	190	5,6

Electrode probe

For use with ES control boxes for supervision of dry running/level control. Suitable for conductive liquids with temperature up to +40°C. Can be connected to electrical panel using 1.5 mm² cable with 550V insulation capacity (not supplied).



ES 0,75 T

1 T - 1,5 T

3 T - 4 T - 7,5 T

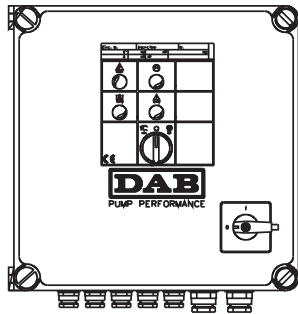

Control box for dry run protection of borehole three-phase electric pumps (see table). The control box is protected and it protects the electric pump from overloads and short circuits, with manual reset. Complete with:

- Terminals for min/max level control (with float switches, pressure switches, etc.)
- Terminals for connection of a remote control
- Pump manual/automatic operation selector
- Timer to control stop time to protect against dry running.
- Protection against excessive number of starts (can be bypassed).
- Terminals (voltage-free) for remote feeding of an audible alarm.

Facility for operation with 1, 2 or 3 sensors, depending on application. Protection rating IP 55. Operating range: from -10°C to +40°C Supplied as standard with an electric probe and wall-mounting brackets. Wall-mounting box in self-extinguishing thermoplastic.

MODEL	POWER INPUT 50-60 HZ	POWER kW P2 MOT.	NOM. DUTY POWER (MAX.) (KW)	MAX CURRENT A	DIMENSIONS			GROSS WEIGHT kg
					A	B	H	
ES 0,75 T	3x400 V~	0,25-0,37-0,55	0,88	1,6	270	300	190	5,6
ES 1 T	3x400 V~	0,75	1,38	2,5	270	300	190	5,6
ES 1,5 T	3x400 V~	1,1	2,2	4	270	300	190	5,6
ES 3 T	3x400 V~	1,5 - 2,2	3,5	6,3	270	300	190	5,6
ES 4 T	3x400 V~	3	5,5	10	270	300	190	5,6
ES 7,5 T	3x400 V~	4-5,5	7,5	14	270	300	190	5,6

ESC 3M - 4T - 10T

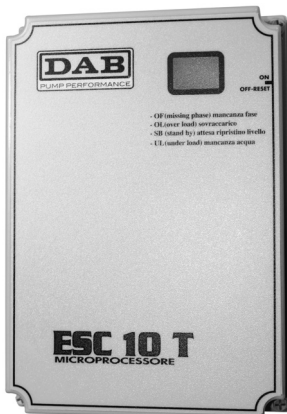

Electric control units for the protection of single and three-phase borehole pumps. The control unit protects the pump from:

- overloads
- phase loss (three-phase version only)
- short circuit
- dry running

The display shows pump operating conditions by means of LEDs:

- Running (green ON)
- Low water level (yellow) – automatic restart test (Stand-by)
- Dry (red) motor stopped (no water)
- Overload (red) – motor stopped (overload)

The water level is not controlled by electrode probes but rather by means of changes of the cos ϕ value (power factor) of the motor. In the case of dry running the system automatically checks 4 times for water level sufficient for automatic starting; after these attempts the motor remains Off (no water).

- protection rating IP 43
- working temperature: from 0°C to +40°C

MODEL	POWER INPUT 50 Hz	MAX POWER kW	MAX CURRENT A	DIMENSIONS			GROSS WEIGHT kg
				A	B	H	
ESC 3 M	1x 220-240V	2,2	18	270	270	165	1,1
ESC 4 T	3x400 V	3,0 incl.	10	270	270	165	1,2
ESC 10 T	3x400 V	4,0-7,5 incl.	20	270	270	165	1,7

TABLES TO ESTABLISH POWER CABLE CROSS SECTION IN RELATION TO LENGTH

Voltage 1x220/240 V ~ direct starting
Voltage drop 3%
Ambient temperature 30°C

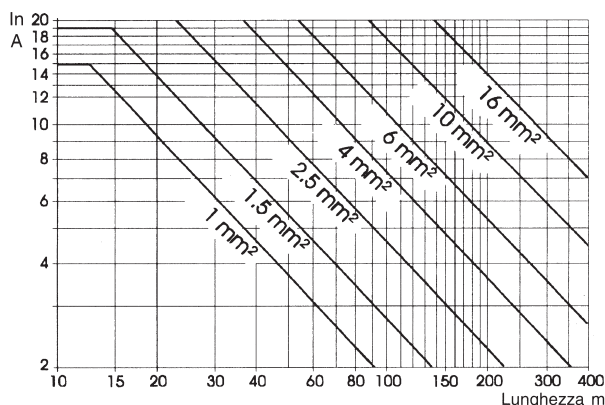

Voltage 3x400 V ~ direct starting
Voltage drop 3%
Ambient temperature 30°C

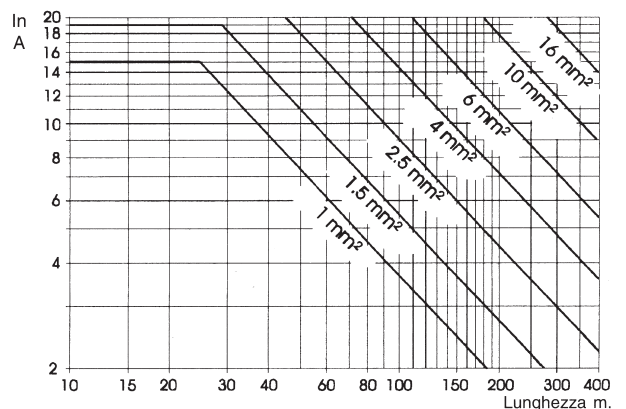

DIVER - DIVER HF

5" BOREHOLE ELECTRIC PUMPS



GENERAL DATA

Applications

DIVER electric pumps are utilised for lifting clear water from boreholes, first water collection tanks or cisterns, wells or water courses and are capable of distributing pressurised water to domestic installations, small agricultural plants, and sprinkler systems for lawns and vegetable gardens. The pump, which is very silent running, can be installed inside boreholes and sumps thus avoiding all potential problems of suction and unpriming.

Pump construction features

Multistage monobloc borehole pump with hydraulic section below motor, which is cooled by the pumped liquid. Impellers and diffusers in fibreglass reinforced Noryl with wear-resistant stainless steel thrust ring. Outer liner, stator sleeve, upper head with delivery connection and closing ring in AISI 304 stainless steel. Canned-type stator. Supports in cast iron. Rotor shaft extension in AISI 304 stainless steel. Lip seal on motor side and silicon carbide/silicon carbide seal on pump side.

Motor construction characteristics

Submerged asynchronous two-pole motor, made entirely of stainless steel, dry design with external cooling by pumped liquid. Canned-type AISI 304L stator

Squirrel cage rotor running on ball bearings, oversized to ensure low noise, reliability and durability.

Single-phase version supplied with CONTROL BOX on request

Overload protection to be provided by the user for the three-phase version.

Automatic version available with float switch.

Available on request with support base and lateral suction (DRY).

Protection rating: IP 68

Insulation class: F

Standard voltage input: single phase 230 V / 50 Hz
three-phase 400 V / 50 Hz

Removable H07RN-F power cable, length 10 m.

TECHNICAL DATA

No.	PART*	MATERIAL
1	CABLE	H07RN-F CEI 20-19
2	SUPPORT	BRASS PCuZn40Pb2 UNI 5705
3	LINER	AISI 304 STAINLESS STEEL X5CrNi1810 UNI 10088-3
4	STATOR	AISI 304L STAINLESS STEEL X2CrNi 1911 UNI 10088-3
5	LIP SEAL	NBR 70
6	MECHANICAL SEAL	SiC/SiC
7	DIFFUSER	TECHNOPOLYMER
8	IMPELLER	TECHNOPOLYMER
9	SHAFT WITH ROTOR	AISI 304 STAINLESS STEEL X5CrNi1810 UNI 10088-3
10	STRAINER	AISI 304 STAINLESS STEEL X5CrNi 1810 UNI 10088-3

* in contact with liquid

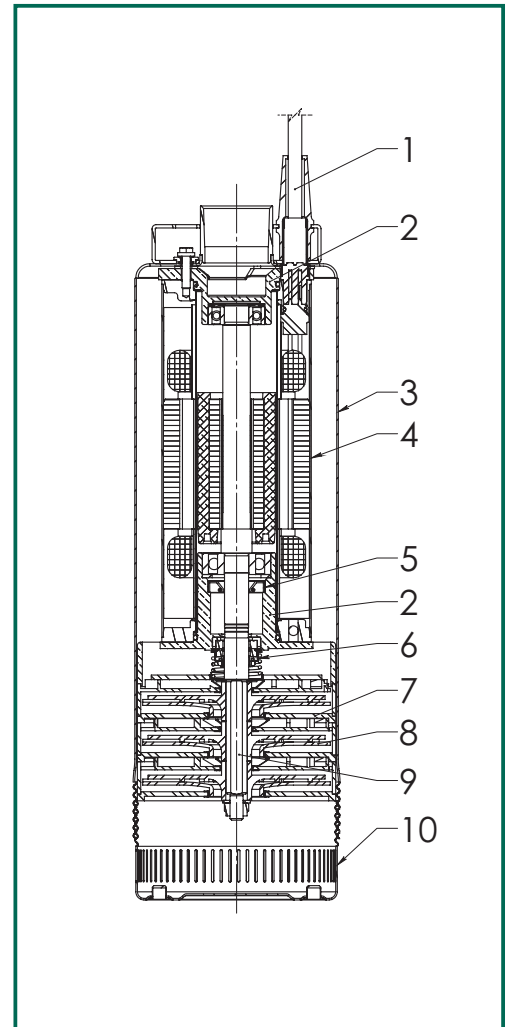

- Operating range: from 0.6 to 12 m³/h with head of up to 96 m.
- Liquid quality requirements: clean, without solid or abrasive contaminants, non aggressive
- Max. percentage of sand in water: 50 gr/m³
- Liquid temperature range: from 0°C to +35°C
- Max. immersion depth: 20 m
- Power supply tolerance: +6% / -10%
- Max. starts: 20/h
- Motor protection rating: IP 68
- Motor protection class: F
- Installation: in wells, tanks and cisterns, in vertical position.
- Special executions on request: alternative voltages and/or frequencies
version with support base and lateral suction
automatic version available with float switch

The performance curves are based on kinematic viscosity values = 1 mm²/s and density equivalent to 1000 kg/m³. Tolerance of curves to ISO 9906.

DIVER

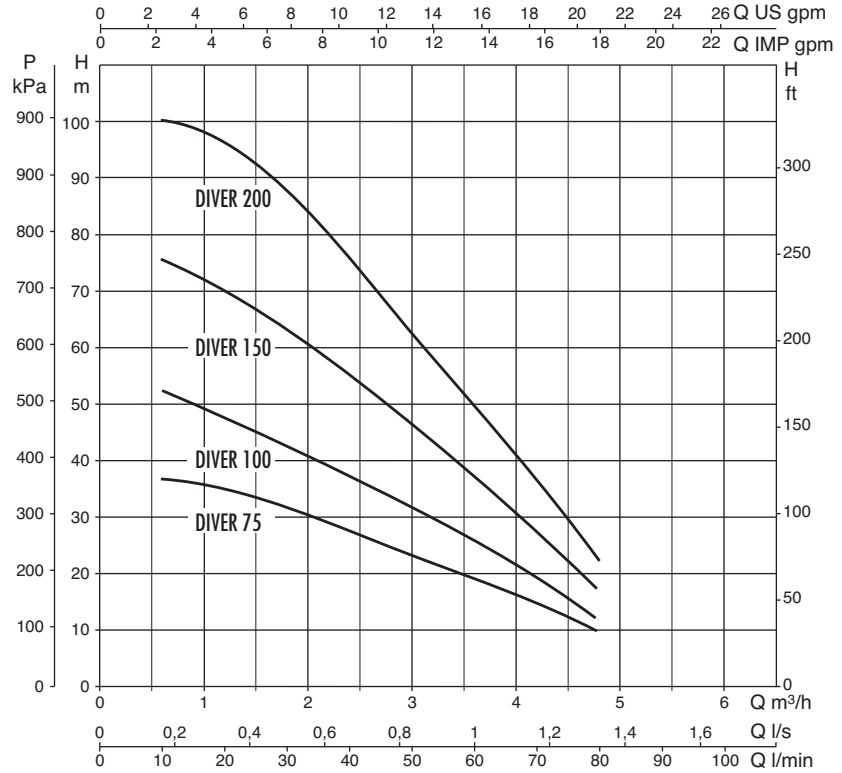
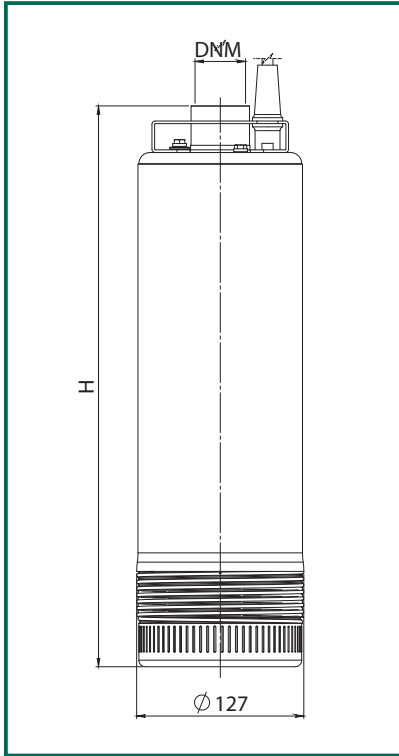

MODEL	Ø (mm)	HEIGHT H (mm)	DNM	PACK DIMENSIONS (mm)			VOLUME m ³	GROSS WEIGHT Kg
				L/A	L/B	H		
DIVER 75 M	127	427	1" 1/4 G	625	230	170	0,024	10
DIVER 100 M	127	482	1" 1/4 G	625	230	170	0,024	11,7
DIVER 150 M	127	550	1" 1/4 G	625	230	170	0,024	13,1
DIVER 200 M	127	648	1" 1/4 G	710	220	160	0,025	15,8
DIVER 75 T	127	427	1" 1/4 G	625	230	170	0,024	10
DIVER 100 T	127	482	1" 1/4 G	625	230	170	0,024	11,7
DIVER 150 T	127	550	1" 1/4 G	625	230	170	0,024	13,1
DIVER 200 T	127	648	1" 1/4 G	710	220	160	0,025	15,8

* Models available with or without float switch.

MODEL	ELECTRICAL DATA							HYDRAULIC DATA									
	POWER SUPPLY 50 Hz	P1 kW	P2		In A	CAPAC.		Q									
			kW	HP		µF	Vc	l/min	0,6	1,2	1,8	2,4	3	3,6	4,2	4,8	
DIVER 75 M	1x230 V ~	0,85	0,55	0,75	4,6	16	450	H (m)	35	33	30	26	22	18	14	9	
DIVER 75 T	3x400 V ~	0,8	0,55	0,75	1,7	-	-		35	33	30	26	22	18	14	9	
DIVER 100 M	1x230 V ~	1,1	0,75	1	5,9	20	450		50	45	41	35	30	25	18	11	
DIVER 100 T	3x400 V ~	1,2	0,75	1	2,4	-	-		50	45	41	35	30	25	18	11	
DIVER 150 M	1x230 V ~	1,6	1	1,5	7,8	30	450		72	67	60	52	45	35	26	16	
DIVER 150 T	3x400 V ~	1,55	1	1,5	3,3	-	-		72	67	60	52	45	35	26	16	
DIVER 200 M	1x230 V ~	2,3	1,5	2	10,7	35	450		96	90	85	70	60	47	35	21	
DIVER 200 T	3x400 V ~	2,15	1,5	2	4,9	-	-		96	90	85	70	60	47	35	21	

The performance curves are based on kinematic viscosity values = 1 mm²/s and density equivalent to 1000 kg/m³. Tolerance of curves to ISO 9906.

DIVER HF

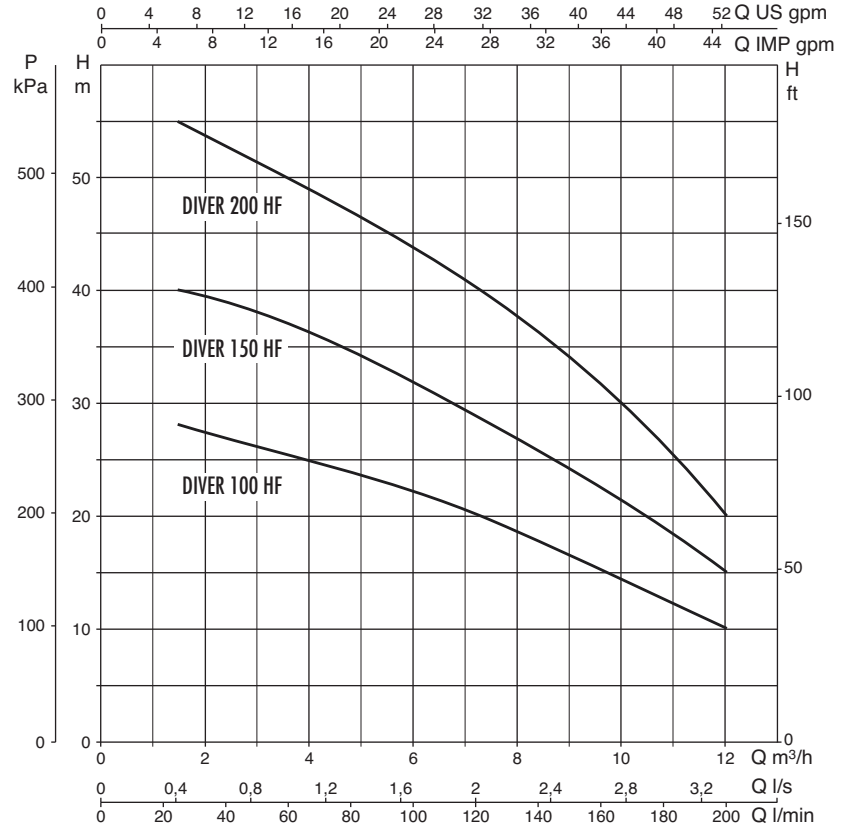
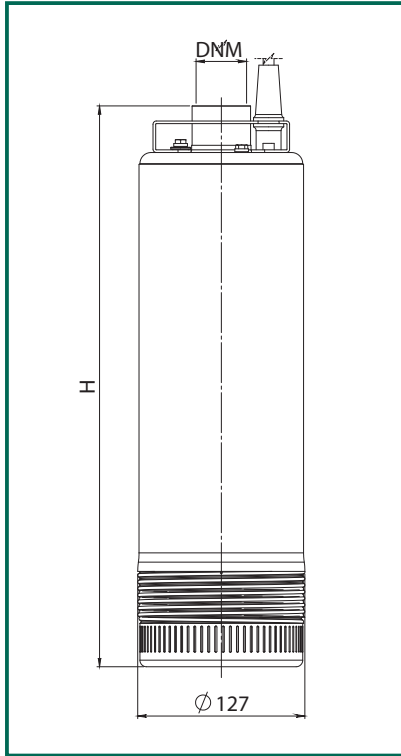

MODEL	Ø (mm)	HEIGHT H (mm)	DNM	PACK DIMENSIONS (mm)			VOLUME m ³	GROSS WEIGHT Kg
				L/A	L/B	H		
DIVER 100 M HF	127	459	1" 1/4 G	625	230	170	0,024	11,5
DIVER 150 M HF	127	523	1" 1/4 G	625	230	170	0,024	13
DIVER 200 M HF	127	608	1" 1/4 G	710	220	160	0,025	15,5
DIVER 100 T HF	127	459	1" 1/4 G	625	230	170	0,024	11,5
DIVER 150 T HF	127	523	1" 1/4 G	625	230	170	0,024	13
DIVER 200 T HF	127	608	1" 1/4 G	710	220	160	0,025	15,5

* Models available with or without float switch.

MODEL	ELECTRICAL DATA							HYDRAULIC DATA											
	POWER SUPPLY 50 Hz	P1			P2		In A	CAPAC.		Q									
		kW	kW	HP	µF	Vc		m ³ /h	1,5	3	4,5	6	7,5	9	10,5	12			
DIVER 100 M HF	1x230 V ~	1,1	0,75	1	6.2	20	450	H (m)	28	26	24	22	20	16	13	10			
DIVER 100 T HF	3x400 V ~	1,2	0,75	1	2.5	-	-		28	26	24	22	20	16	13	10			
DIVER 150 M HF	1x230 V ~	1,7	1	1,5	8.1	30	450		40	38	35	32	28	24	20	15			
DIVER 150 T HF	3x400 V ~	1,8	1	1,5	3.5	-	-		40	38	35	32	28	24	20	15			
DIVER 200 M HF	1x230 V ~	2,15	1,5	2	10.8	35	450		55	51	48	44	39	34	28	20			
DIVER 200 T HF	3x400 V ~	2,1	1,5	2	4.9	-	-		55	51	48	44	39	34	28	20			

PULSAR

5" BOREHOLE ELECTRIC PUMPS



GENERAL DATA

Applications

PULSAR electric pumps are utilised for lifting clear water from boreholes, first water collection tanks or cisterns, wells or water courses and are capable of distributing pressurised water to domestic installations, small agricultural plants, and sprinkler systems for lawns and vegetable gardens. The pump, which is very silent running, can be installed inside boreholes and sumps thus avoiding all potential problems of suction and loss of priming.

Pump construction features

Multistage monobloc borehole pump with hydraulic section below motor, which is cooled by the pumped liquid. Impellers, diffusers, strainer and oil sump in abrasion-proof thermoplastic. Outer liner, stator sleeve, upper head with delivery connection and closing ring in AISI 304 stainless steel. Upper and lower bearing support in anti-dezincification pressed brass. Impeller shaft extension in AISI 304. Elastomers in NBR Stainless steel screws. Double mechanical seal with interposed oil chamber, in ceramic/carbon on motor side and silicon carbide/silicon carbide on pump side. The seal system adopted ensures watertight sealing of the motor and correct operation of the mechanical seal even in the event of short duration dry running.

Motor construction characteristics

Submerged type with continuous duty asynchronous motor. Stator enclosed in airtight casing made of AISI 304 stainless steel and enclosed in a case that protects wiring and capacitor. Rotor running on ball bearings, oversized to ensure low noise and durability. Integral thermal and overload protection and permanently connected capacitor in single phase version. For protection of the three-phase motor we recommend the use of remote overload cut-outs in compliance with statutory regulations. Construction to CEI 2-3 and CEI 61-69 (EN 60335-2-41).

Motor protection rating: IP 68

Insulation class: F

Standard voltage: Single phase 220/240V V / 50 Hz
 Three-phase 400V / 50 Hz

Standard cables: 20 m cable type H07 RN-F, complete with SCHUKO CEE 7-VII-UNEL 47166-68 plug for single-phase version. Single-phase versions can be equipped with or without float switches for automatic operation.

TECHNICAL DATA

No.	PART (*)	MATERIAL
4*	IMPELLER	TECHNOPOLYMER
6*	DIFFUSER	TECHNOPOLYMER
7*	SHAFT WITH ROTOR	AISI 304 (Pumped liquid contact part)
10*	MOTOR CASING WITH WOUND STATOR	AISI 304
16*	COMPLETE UPPER MECHANICAL SEAL	NBR/CERAMIC/CARBON
16b	COMPLETE LOWER MECHANICAL SEAL	NBR/SILICON/CARBON
42*	SUCTION STRAINER	TECHNOPOLYMER
77*	LINER	AISI 304
81*	UPPER BEARING SUPPORT	PRESSED BRASS
82*	LOWER BEARING SUPPORT	PRESSED BRASS
92*	STRAINER COVER	AISI 304
98*	DIFFUSER HOUSING	TECHNOPOLYMER
105*	SUMP	TECHNOPOLYMER
115	SEAL LUBRICATING FLUID	ESSO MARCOL 172 OIL
170*	WIRING COMPARTMENT COVER	TECHNOPOLYMER
304*	REAR DISC	TECHNOPOLYMER

*in contact with the pumped liquid

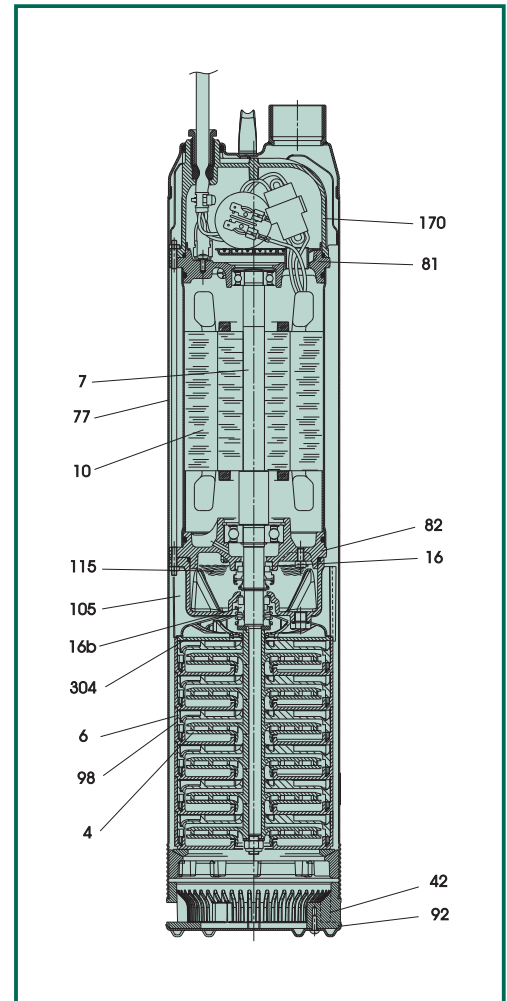

- Operating range: from 0.9 to 7.2 m³/h with head of up to 86 m.
- Liquid quality requirements: clean, without solid or abrasive contaminants, non aggressive.
- Max. percentage of sand in water: 50 gr/m³
- Liquid temperature range: from 0°C to +40°C
- Maximum immersion depth: 20 metres
- Motor protection rating: IP 68
- Motor protection class: F
- Installation: fixed or portable in vertical or horizontal position.
- Operation: manual or automatic (continuous duty with totally borehole pump)
- Discharge port diameter: 1"1/4 GAS
- Pump maximum diameter: 138 mm

The performance curves are based on kinematic viscosity values = 1 mm²/s and density equivalent to 1000 kg/m³. Tolerance of curves to ISO 9906.

PULSAR 50

Liquid temperature range: from 0°C to +40°C

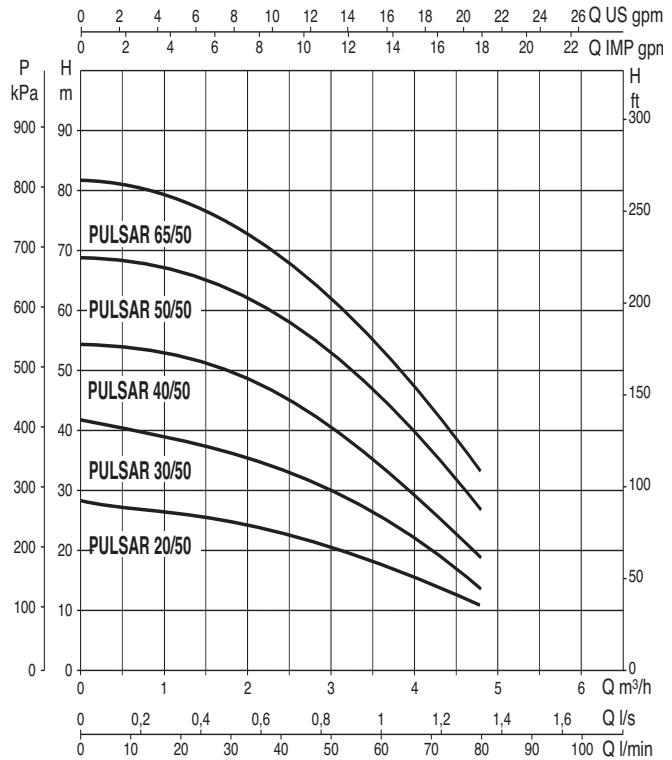
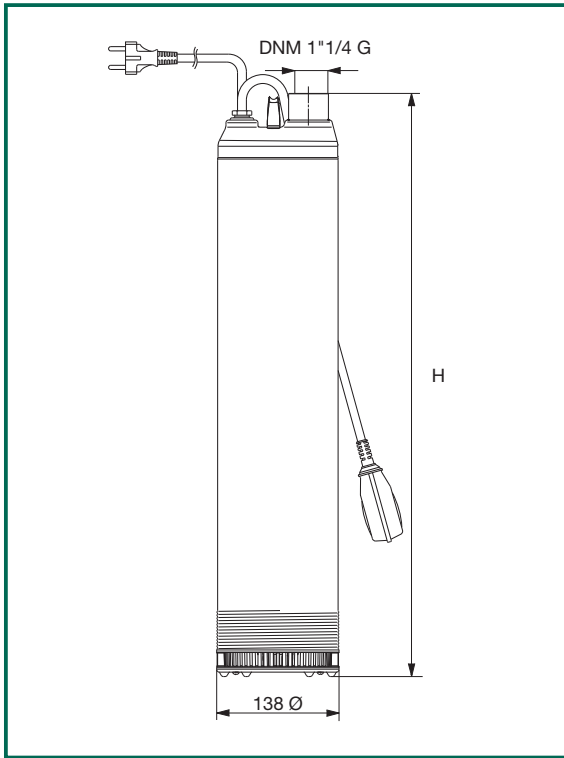

MODEL	Ø (mm)	HEIGHT H (mm)	DNM	PACK DIMENSIONS (mm)			VOLUME m ³	GROSS WEIGHT Kg		
				L/A	L/B	H		MA*	MNA*	TNA*
PULSAR 20/50	224	603	1" 1/4 G	780	240	265	0,049		16,5	17
PULSAR 30/50	138	562	1" 1/4 G	690	220	165	0,025	17,3	16,7	17,3
PULSAR 40/50	138	562	1" 1/4 G	690	220	165	0,025	17,5	17	17,5
PULSAR 50/50	138	630	1" 1/4 G	690	220	165	0,025	18,5	18	18,5
PULSAR 65/50	138	657	1" 1/4 G	690	220	165	0,025	19,5	19	19,5

* Models available with or without float switch.

MODEL	ELECTRICAL DATA							HYDRAULIC DATA					
	POWER SUPPLY 50 Hz	P1 kW	P2		In A	CAPAC.		Q m ³ /h l/min	H (m)				
			kW	HP		μF	Vc		0	1,2	2,4	3,6	4,8
PULSAR 20/50 M	220-240 V~	0,78	0,55	0,75	3,7	20	450	H (m)	29	27	23,2	17,2	10,3
PULSAR 20/50 T	400 V~	0,6	0,55	0,75	1,62	-	-		42	38,2	33,8	24,8	13,5
PULSAR 30/50 M	220-240 V~	1	0,55	0,75	4,5	20	450		54,9	52,4	45,8	34,8	19,4
PULSAR 30/50 T	400 V~	0,9	0,55	0,75	1,8	-	-		68,8	66,6	59	45,4	27,4
PULSAR 40/50 M	220-240 V~	1,2	0,75	1	5,5	20	450		81,9	78,9	69,6	54,6	33,9
PULSAR 40/50 T	400 V~	1,1	0,75	1	2	-	-						
PULSAR 50/50 M	220-240 V~	1,5	1	1,36	7	25	450						
PULSAR 50/50 T	400 V~	1,4	1	1,36	2,6	-	-						
PULSAR 65/50 M	220-240 V~	1,8	1,2	1,6	8	30	450						
PULSAR 65/50 T	400 V~	1,7	1,2	1,6	3,1	-	-						

The performance curves are based on kinematic viscosity values = 1 mm²/s and density equivalent to 1000 kg/m³. Tolerance of curves to ISO 9906.

PULSAR 80

Liquid temperature range: from 0°C to +40°C

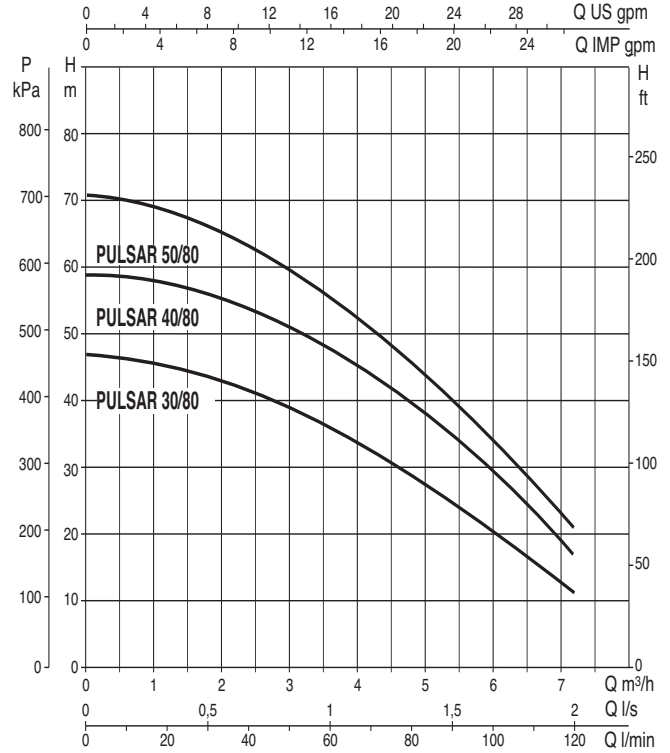
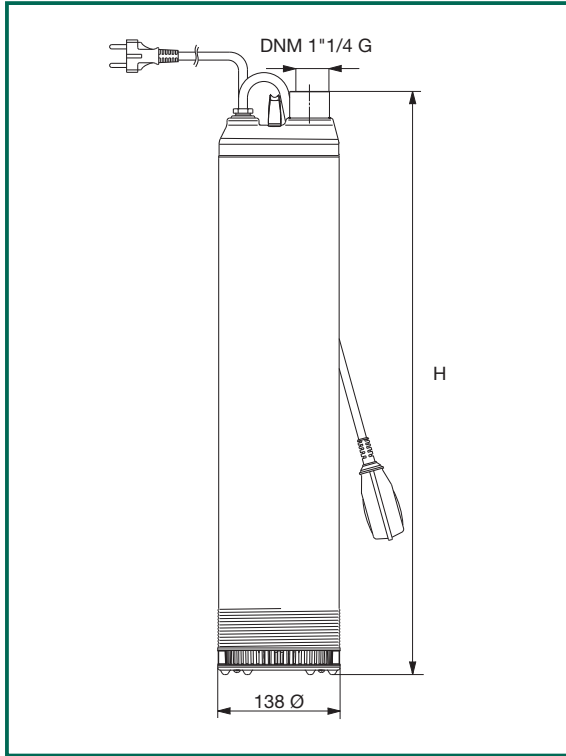

MODEL	Ø (mm)	HEIGHT H (mm)	DNM	PACK DIMENSIONS (mm)			VOLUME m ³	GROSS WEIGHT Kg		
				L/A	L/B	H		MA*	MNA*	TNA*
PULSAR 30/80	138	562	1" 1/4 G	690	220	165	0,025	17,5	17	17,5
PULSAR 40/80	138	630	1" 1/4 G	690	220	165	0,025	18,5	18	18,5
PULSAR 50/80	138	657	1" 1/4 G	690	220	165	0,025	19,5	19	19,5

* Models available with or without float switch.

MODEL	ELECTRICAL DATA							HYDRAULIC DATA							
	POWER SUPPLY 50 Hz	P2			In A	CAPAC.		Q m ³ /h l/min	H (m)						
		P1 kW	kW	HP		μF	Vc		0	1,2	2,4	3,6	4,8	6	7,2
PULSAR 30/80 M	220-240 V~	1,2	0,75	1	5,4	20	450	H (m)	46,8	46	42	35,3	30	20	11
PULSAR 30/80 T	400 V~	1,1	0,75	1	2	-	-		59,2	58,5	54	46,9	40	29	17
PULSAR 40/80 M	220-240 V~	1,5	1	1,36	7	25	450		70,7	68,2	63,3	54,9	45,8	34,5	20,3
PULSAR 40/80 T	400 V~	1,4	1	1,36	2,5	-	-								
PULSAR 50/80 M	220-240 V~	1,8	1,2	1,6	8,2	30	450								
PULSAR 50/80 T	400 V~	1,6	1,2	1,6	3	-	-								

PULSAR DRY 5" ELECTRIC PUMPS



GENERAL DATA

Applications

PULSAR electric pumps are utilised for lifting clear water from boreholes, first water collection tanks or cisterns, wells or water courses and are capable of distributing pressurised water to domestic installations, small agricultural plants, and sprinkler systems for lawns and vegetable gardens. The pump, which is very silent running, can be installed inside boreholes and sumps thus avoiding all potential problems of suction and loss of priming.

Pump construction features

Multistage monobloc borehole pump with hydraulic section below motor, which is cooled by the pumped liquid. Impellers, diffusers, strainer and oil sump in abrasion-proof thermoplastic. Outer liner, stator sleeve, upper head with delivery connection and closing ring in AISI 304 stainless steel. Upper and lower bearing support in anti-dezincification pressed brass. Impeller shaft extension in AISI 304. Elastomers in NBR Stainless steel screws. Double mechanical seal with interposed oil chamber, in ceramic/carbon on motor side and silicon carbide/silicon carbide on pump side. The seal system adopted ensures watertight sealing of the motor and correct operation of the mechanical seal even in the event of short duration dry running.

Motor construction characteristics

Submerged type with continuous duty asynchronous motor. Stator enclosed in airtight casing made of AISI 304 stainless steel and enclosed in a case that protects wiring and capacitor. Rotor running on ball bearings, oversized to ensure low noise and durability Integral thermal and overload protection and permanently connected capacitor in single phase version. For protection of the three-phase motor we recommend the use of remote overload cut-outs in compliance with statutory regulations. Construction to CEI 2-3 and CEI 61-69 (EN 60335-2-41).

Motor protection rating: IP 68

Insulation class: F

Standard voltage: Single phase 220/240V V / 50 Hz
 Three-phase 400V / 50 Hz

Standard cables: 20 m cable type H07 RN-F, complete with SCHUKO CEE 7-VII-UNEL 47166-68 plug for single-phase version. Single-phase versions can be equipped with or without float switches for automatic operation.

TECHNICAL DATA

No.	PART (*)	MATERIAL
4*	IMPELLER	TECHNOPOLYMER
6*	DIFFUSER	TECHNOPOLYMER
7*	SHAFT WITH ROTOR	AISI 304 (Pumped liquid contact part)
10*	MOTOR CASING WITH WOUND STATOR	AISI 304
16*	COMPLETE UPPER MECHANICAL SEAL	NBR/CERAMIC/CARBON
16b	COMPLETE LOWER MECHANICAL SEAL	NBR/SILICON/CARBON
77*	LINER	AISI 304
81*	UPPER BEARING SUPPORT	PRESSED BRASS
82*	LOWER BEARING SUPPORT	PRESSED BRASS
98*	DIFFUSER HOUSING	TECHNOPOLYMER
105*	SUMP	TECHNOPOLYMER
115	SEAL LUBRICATION FLUID	ESSO MARCOL 172 OIL
170*	WIRING COMPARTMENT COVER	TECHNOPOLYMER
304*	REAR DISC	TECHNOPOLYMER

*in contact with the pumped liquid

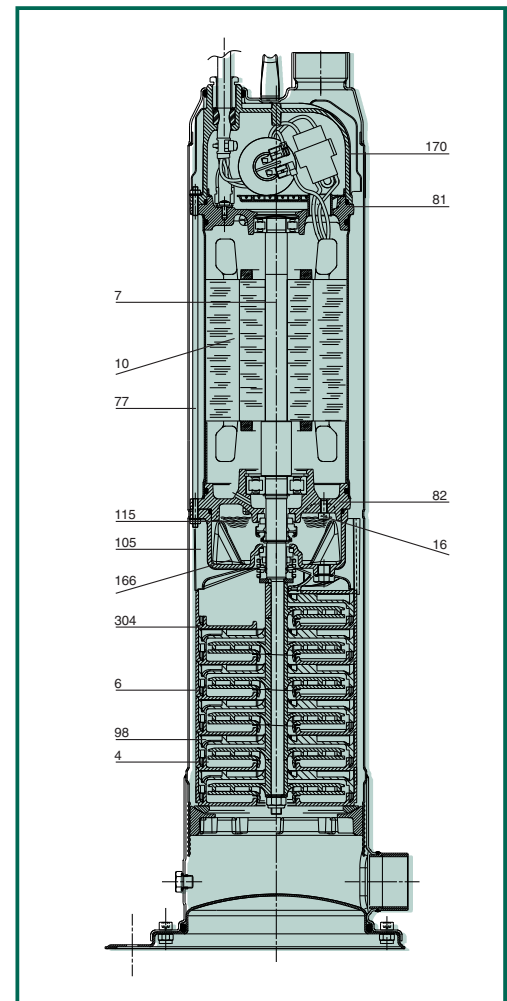

- Operating range: from 0.9 to 7.2 m³/h with head of up to 86 m.
- Liquid quality requirements: clean, without solid or abrasive contaminants, non aggressive.
- Max. percentage of sand in water: 50 gr/m³
- Liquid temperature range: from 0°C to +40°C
- Maximum immersion depth: 20 metres
- Motor protection rating: IP 68
- Motor protection class: F
- Maximum working pressure: 10 bar
- Installation: fixed or portable in vertical or horizontal position.
- Operation: manual or automatic (continuous duty with totally borehole pump)
- Discharge port diameter: 1"1/4 GAS
- Pump maximum diameter: 138 mm

The performance curves are based on kinematic viscosity values = 1 mm²/s and density equivalent to 1000 kg/m³. Tolerance of curves to ISO 9906.

PULSAR DRY 50

Liquid temperature range: from 0°C to +40°C

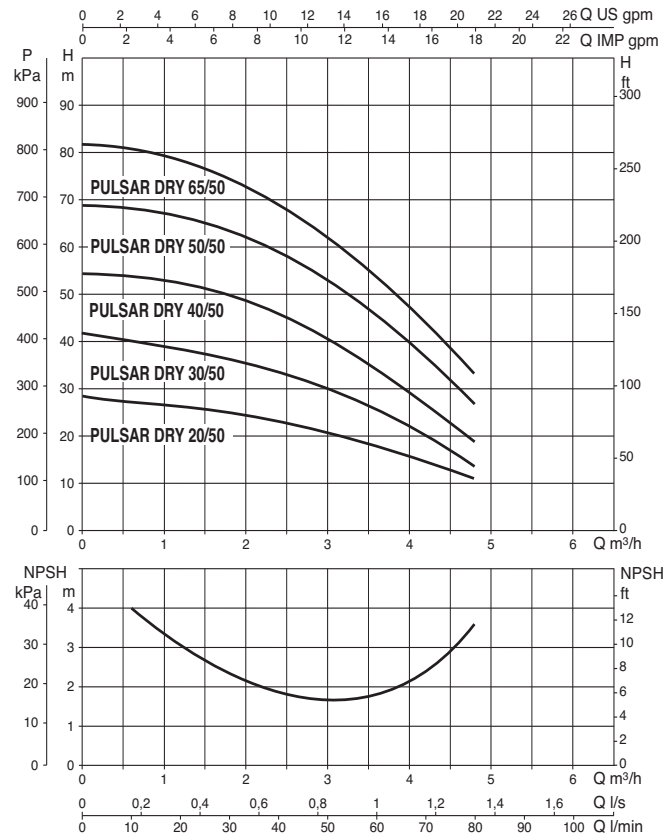
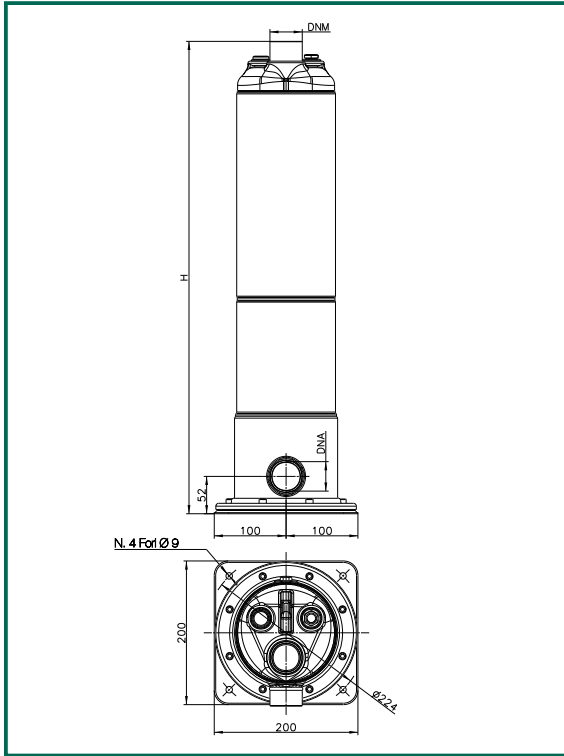

MODEL	Ø (mm)	HEIGHT H (mm)	DNM DNA	PACK DIMENSIONS (mm)			VOLUME m ³	GROSS WEIGHT Kg	
				L/A	L/B	H		MNA*	TNA*
PULSAR DRY 20/50	224	603	1" 1/4 G	780	240	265	0,049	16,5	17
PULSAR DRY 30/50	224	603	1" 1/4 G	780	240	265	0,049	16,7	17,3
PULSAR DRY 40/50	224	603	1" 1/4 G	780	240	265	0,049	17	17,5
PULSAR DRY 50/50	224	670	1" 1/4 G	780	240	265	0,049	18	18,5
PULSAR DRY 65/50	224	697	1" 1/4 G	780	240	265	0,049	19	19,5

MODEL	ELECTRICAL DATA							HYDRAULIC DATA					
	POWER SUPPLY 50 Hz	P1 kW	P2		In A	CAPAC.		Q m ³ /h l/min	H (m)				
			kW	HP		µF	Vc		0	1,2	2,4	3,6	4,8
PULSAR DRY 20/50 M-NA	220-240 V~	0,78	0,55	0,75	3,7	20	450	H (m)	29	27	23,2	17,2	10,3
PULSAR DRY 20/50 T-NA	400 V~	0,6	0,55	0,75	1,62	-	-		42	38,2	33,8	24,8	13,5
PULSAR DRY 30/50 M-NA	220-240 V~	1,0	0,55	0,75	4,5	20	450		54,9	52,4	45,8	34,8	19,4
PULSAR DRY 30/50 T-NA	400 V~	0,9	0,55	0,75	1,8	-	-		68,8	66,6	59	45,4	27,4
PULSAR DRY 40/50 M-NA	220-240 V~	1,2	0,75	1	5,5	20	450		81,9	78,9	69,6	54,6	33,9
PULSAR DRY 40/50 T-NA	400 V~	1,1	0,75	1	2	-	-						
PULSAR DRY 50/50 M-NA	220-240 V~	1,5	1	1,36	7	25	450						
PULSAR DRY 50/50 T-NA	400 V~	1,4	1	1,36	2,6	-	-						
PULSAR DRY 65/50 M-NA	220-240 V~	1,8	1,2	1,6	8	30	450						
PULSAR DRY 65/50 T-NA	400 V~	1,7	1,2	1,6	3,1	-	-						

* NA = not automatic

The performance curves are based on kinematic viscosity values = 1 mm²/s and density equivalent to 1000 kg/m³. Tolerance of curves to ISO 9906.

PULSAR DRY 80

Liquid temperature range: from 0°C to +40°C

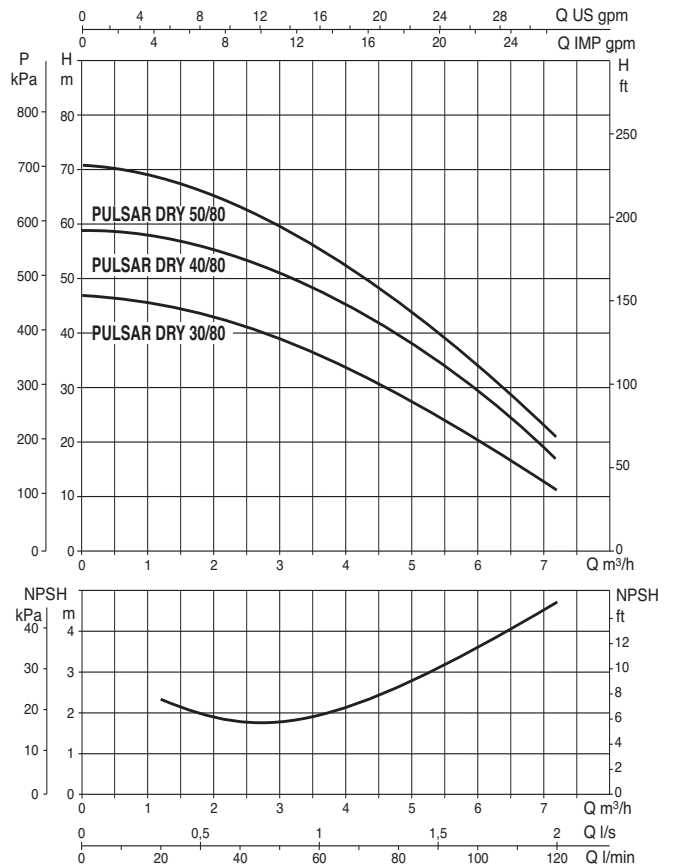
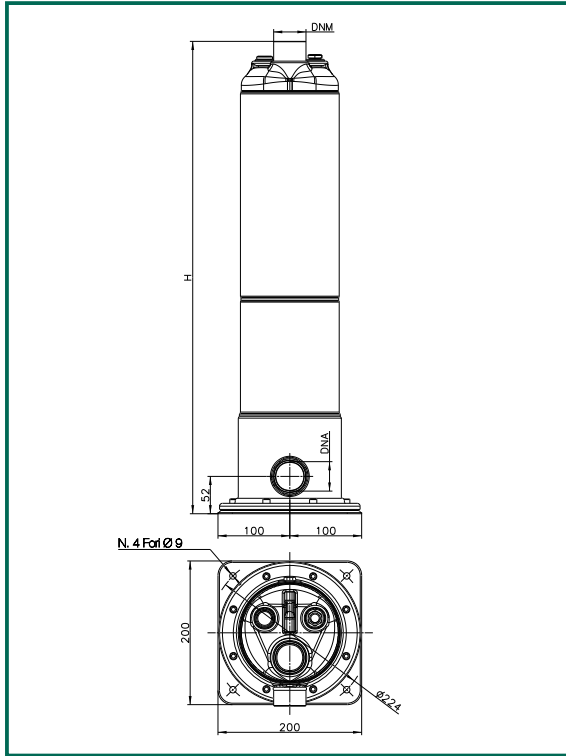

MODEL	Ø (mm)	HEIGHT H (mm)	DNM DNA	PACK DIMENSIONS (mm)			VOLUME m ³	GROSS WEIGHT Kg	
				L/A	L/B	H		MNA*	TNA*
PULSAR DRY 30/80	224	603	1" 1/4 G	780	240	265	0,049	17	17,5
PULSAR DRY 40/80	224	670	1" 1/4 G	780	240	265	0,049	18	18,5
PULSAR DRY 50/80	224	697	1" 1/4 G	780	240	265	0,049	19	19,5

MODEL	ELECTRICAL DATA							HYDRAULIC DATA								
	POWER SUPPLY 50 Hz	P2			In A	CAPAC.		Q m ³ /h l/min	H (m)							
		P1 kW	kW	HP		μF	Vc		0	1,2	2,4	3,6	4,8	6	7,2	
PULSAR DRY 30/80 M-NA	220-240 V~	1,2	0,75	1	5,4	20	450	H (m)	46,8	46	42	35,3	30	20	11	
PULSAR DRY 30/80 T-NA	400 V~	1,2	0,75	1	2	-	-		59,2	58,5	54	46,9	40	29	17	
PULSAR DRY 40/80 M-NA	220-240 V~	1,5	1	1,36	7	25	450		70,7	68,2	63,3	54,9	45,8	34,5	20,3	
PULSAR DRY 40/80 T-NA	400 V~	1,4	1	1,36	2,5	-	-									
PULSAR DRY 50/80 M-NA	220-240 V~	1,8	1,2	1,6	8,2	30	450									
PULSAR DRY 50/80 T-NA	400 V~	1,6	1,2	1,6	3	-	-									

* NA = not automatic

BOREHOLE ELECTRIC PUMPS FOR 6" WELLS



GENERAL DATA

Applications

Borehole electric pump for 6" wells or larger, capable of generating a broad range of flow rates and heads.

These units have a very extensive range of applications for lifting, distribution and pressurisation in civil and industrial water systems, filling of pressure vessels and tanks, fire-fighting and washing installations, and irrigation systems.

Pump construction features

Motor support and discharge section in stainless spheroidal cast iron (NiResist D2B).

Lower support sized to NEMA 6".

Check valve incorporated in discharge support

Plain bearings: bronze rubber. Completely protected splined shaft (AISI 420). Wear rings, stage box, cable sheath, suction grid in stainless steel (AISI 304). Impellers and diffusers in Noryl.

Motor construction characteristics

Submerged asynchronous two-pole motor made entirely of AISI 304 stainless steel and cast iron with paint coating.

Squirrel cage rotor mounted on self-centring thrust block designed to withstand significant axial loads.

Canned-type stator housed in an airtight stainless steel casing. Bearings are lubricated by a mixture of water and glycole.

Overload protection to be provided by the user in compliance with EN 60947-4-1 (Trip time <10 sec. at 5 x I_n).

Coupling flange dimensions to NEMA 6".

Flanging to NEMA – 6"

Protection rating: IP 68

Insulation class: F

Input voltage: three-phase 400 V / 50Hz (+6% -10% U_n)

TECHNICAL DATA

No.	PART (*)	MATERIAL
3	BASE SUPPORT	SPHEROIDAL CAST IRON
4	IMPELLER	TECHNOPOLYMER
6	DIFFUSER	TECHNOPOLYMER
34	DISC	TECHNOPOLYMER
40	COUPLING	STAINLESS STEEL
44	CLEARANCE WASHER	STAINLESS STEEL
55	SPACER BUSH	AISI 304 STAINLESS STEEL
57	SUCTION SIDE SUPPORT	AISI 304 STAINLESS STEEL
57A	INTERMEDIATE SUPPORT	AISI 304 STAINLESS STEEL
58	SHAFT JACKET	BRONZE
66	COUNTER-THRUST RING	AISI 304 STAINLESS STEEL
69	PUMP LINER	AISI 304 STAINLESS STEEL
98	DIFFUSER BODY	AISI 304 STAINLESS STEEL
117	VALVE BODY	SPHEROIDAL CAST IRON

* In contact with liquid

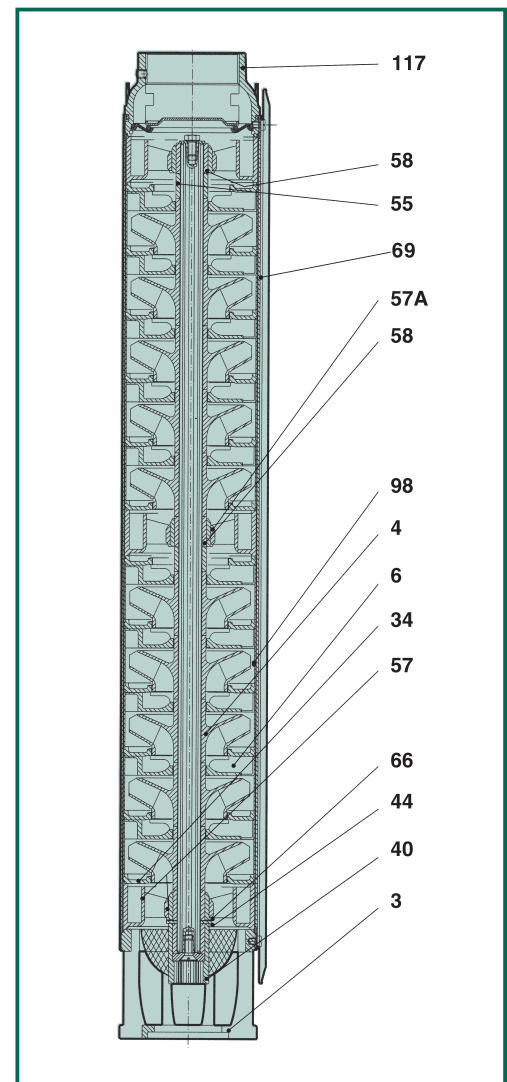

- Operating range: up to 66 m³/h with head of up to 468 m.
- Liquid quality requirements: clean, free of solid or abrasive contaminants, chemically neutral, close to the properties of water.
- N° starts / hour: max 20
- Cooling flow: 16 cm/sec.
- Maximum permissible sand quantity: 40 gr/m³
- Ambient temperature: 30°C
- Minimum recommended suction level: mt.1
- Accessories: see page 53
- Installation: horizontal or vertical

The performance curves are based on kinematic viscosity values = 1 mm²/s and density equivalent to 1000 kg/m³. Tolerance of curves to ISO 9906.

S6B

Maximum ambient temperature: 30°C

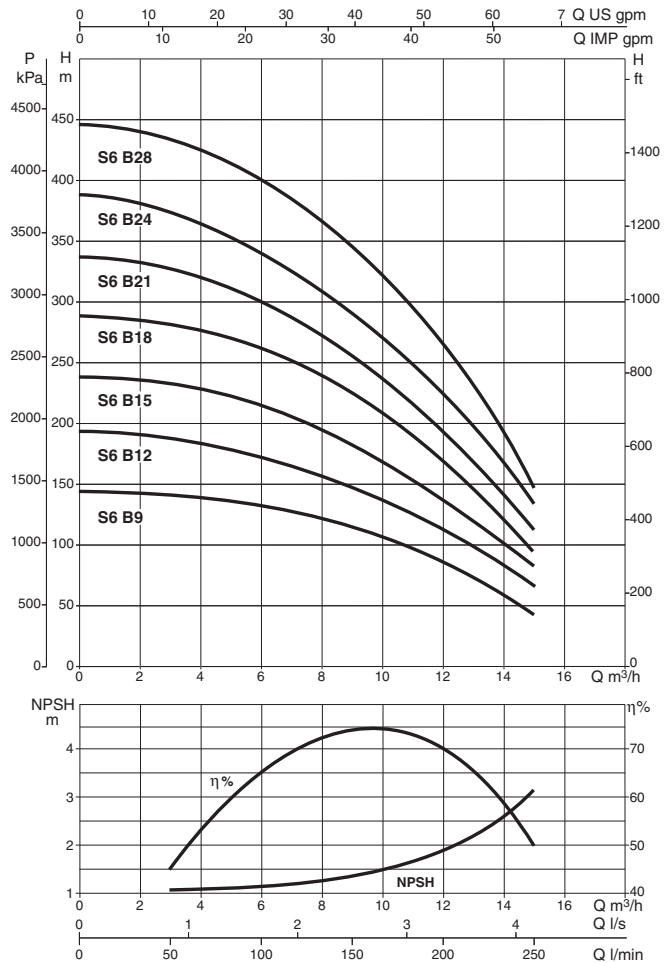
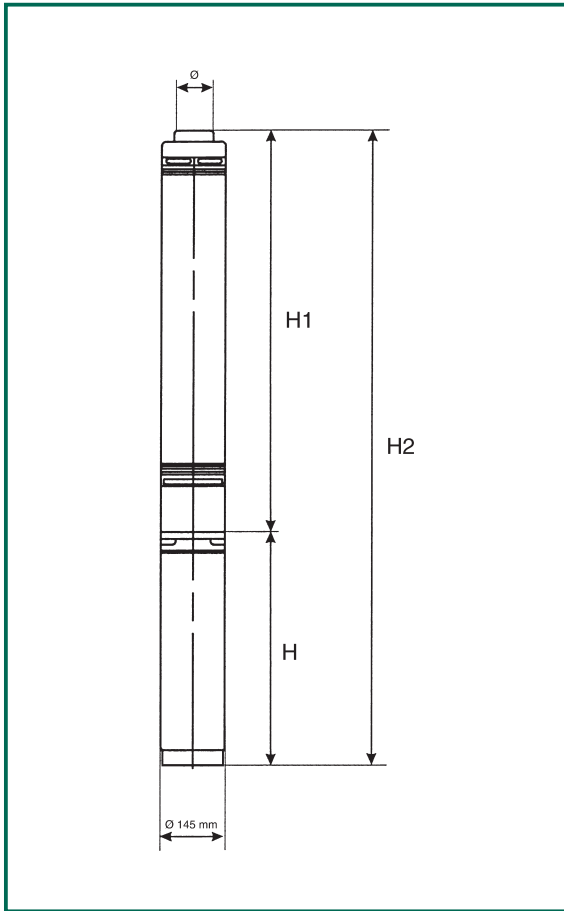

MODEL	REQUIRED MOTOR POWER		HYDRAULIC DATA (n = 2850 1/min)							H1 (mm)	H2 (mm)	Weight of pump	Total weight	Ø
			Q	0	6	8,4	10,8	12	15					
			m ³ /h	0	100	140	180	200	250					
S6B-9	4	5,5	H (m)	147	125	114	96	85	46	625	1225	11	50,5	3"
S6B-12	5,5	7,5		196	172	152	128	113	64	738	1369	13,5	56,7	3"
S6B-15	7,5	10		224	216	190	160	141	80	852	1512	15	60,5	3"
S6B-18	9,2	12,5		293	250	228	193	169	96	966	1651	17	66	3"
S6B-21	9,2	12,5		342	291	266	225	197	112	1079	1764	19,5	68,5	3"
S6B-24	11	15		391	340	304	257	226	128	1193	1923	21	74	3"
S6B-28	13	17,5		446	400	354	300	263	149	1397	2182	23,5	82,5	3"

MODEL	MOTORS										
	H (mm)	WEIGHT Kg.	Axial load N	1/m	Power input 50 Hz	Installed Power kW	HP	I _N	I _A	η (%)	cos φ
S6B-9	600	39,5	16000	2845	3X400 V ~	4	5,5	10,6	43	76	0,75
S6B-12	631	43,2	16000	2840	3X400 V ~	5,5	7,5	14	65	76	0,75
S6B-15	660	45,5	16000	2840	3X400 V ~	7,5	10	18	74	78	0,78
S6B-18	685	49	16000	2840	3X400 V ~	9,2	12,5	22	85	80	0,8
S6B-21	685	49	16000	2840	3X400 V ~	9,2	12,5	22	85	80	0,8
S6B-24	730	53	16000	2840	3X400 V ~	11	15	25,5	113	79	0,82
S6B-28	785	59	16000	2840	3X400 V ~	15	20	33,4	160	83	0,8

The performance curves are based on kinematic viscosity values = 1 mm²/s and density equivalent to 1000 kg/m³. Tolerance of curves to ISO 9906.

S6D

Maximum ambient temperature: 30°C

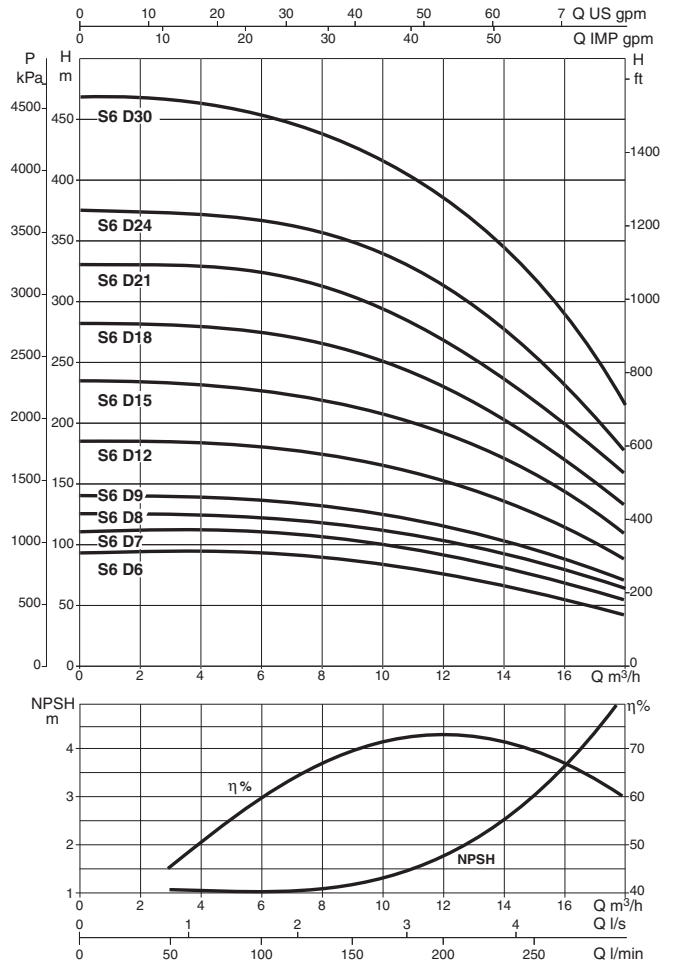
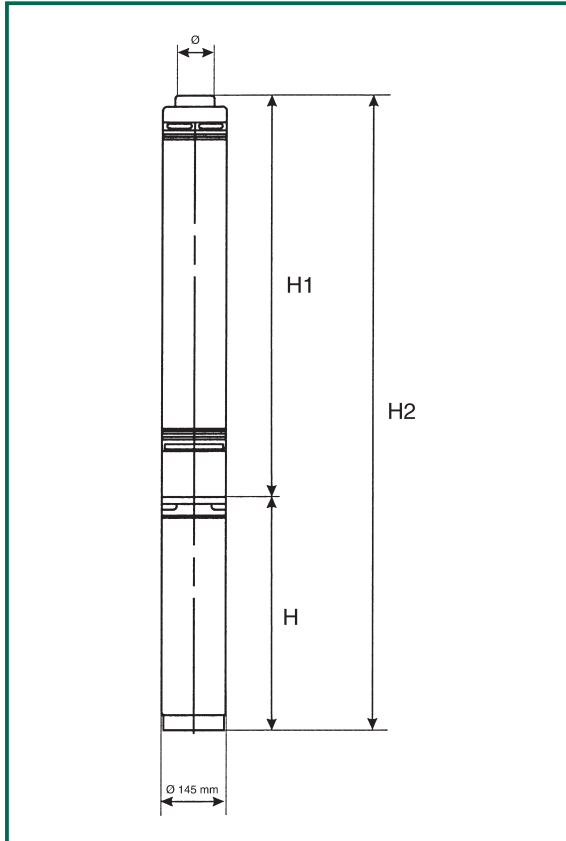

MODEL	P2		HYDRAULIC DATA (n = 2850 1/min)							H1 (mm)	H2 (mm)	Weight of pump	Total weight	Ø
	NOMINAL		Q m³/h	0	8,4	10,8	12	15	18					
	kW	HP												
S6D-6	3,7	5	H (m)	94	87	80	76	63	44	511	1111	9	48,5	3"
S6D-7	5,5	7,5		109	101	93	89	74	51	549	1180	9,5	52,7	3"
S6D-8	5,5	7,5		125	115	106	102	84	58	587	1218	11	54,2	3"
S6D-9	5,5	7,5		140	130	120	114	95	66	625	1256	11	55,2	3"
S6D-12	7,5	10		187	173	160	153	127	88	738	1398	13,5	59	3"
S6D-15	9,2	12,5		234	216	201	191	158	110	852	1537	15	64	3"
S6D-18	11	15		281	260	241	229	190	132	966	1696	17	70	3"
S6D-21	13	17,5		328	304	281	267	222	154	1079	1864	19	78	3"
S6D-24	15	20		374	347	321	305	254	176	1193	1978	21	80	3"
S6D-30	18,5	25		468	464	401	381	317	220	1474	2334	25	91,5	3"

MODEL	MOTORS										
	H (mm)	WEIGHT Kg.	Axial load N	1/m	Power input 50 Hz	Installed Power kW HP		I _N	I _A	η (%)	cos φ
S6D-6	600	39,5	16000	2845	3X400 V ~	4	5,5	10,6	43	76	0,75
S6D-7	631	43,2	16000	2840	3X400 V ~	5,5	7,5	14	65	76	0,75
S6D-8	631	43,2	16000	2840	3X400 V ~	5,5	7,5	14	65	76	0,75
S6D-9	631	43,2	16000	2840	3X400 V ~	5,5	7,5	14	65	76	0,75
S6D-12	660	45,5	16000	2840	3X400 V ~	7,5	10	18	74	78	0,78
S6D-15	685	49	16000	2840	3X400 V ~	9,2	12,5	22	85	80	0,8
S6D-18	730	53	16000	2840	3X400 V ~	11	15	25,5	113	79	0,82
S6D-21	785	59	16000	2840	3X400 V ~	15	20	33,4	160	83	0,8
S6D-24	785	59	16000	2840	3X400 V ~	15	20	33,4	160	83	0,8
S6D-30	860	66,5	16000	2845	3X400 V ~	18,5	25	41	215	83	0,8

The performance curves are based on kinematic viscosity values = 1 mm²/s and density equivalent to 1000 kg/m³. Tolerance of curves to ISO 9906.

S6F

Maximum ambient temperature: 30°C

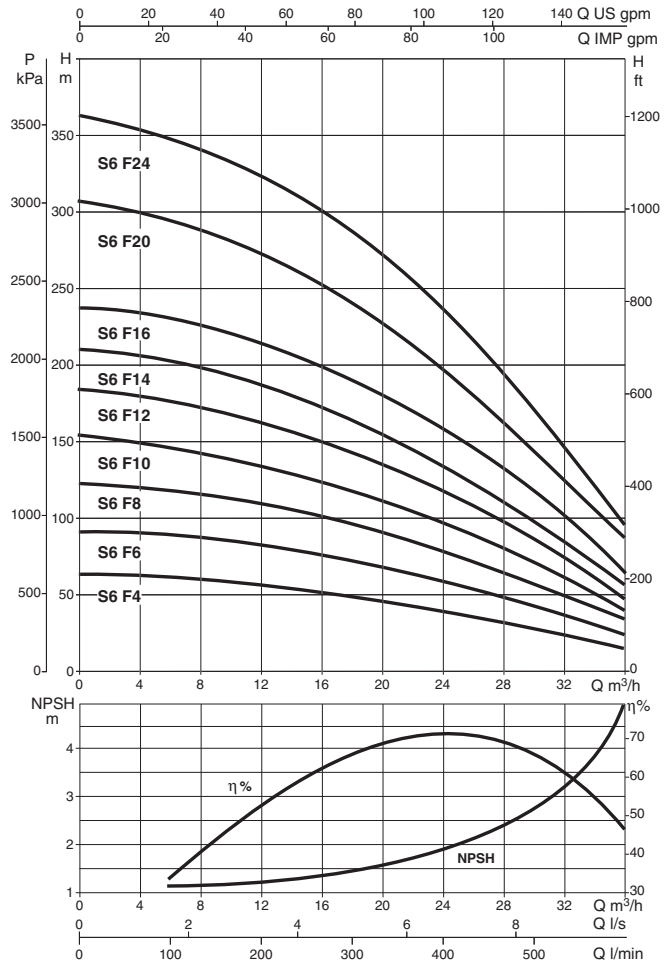
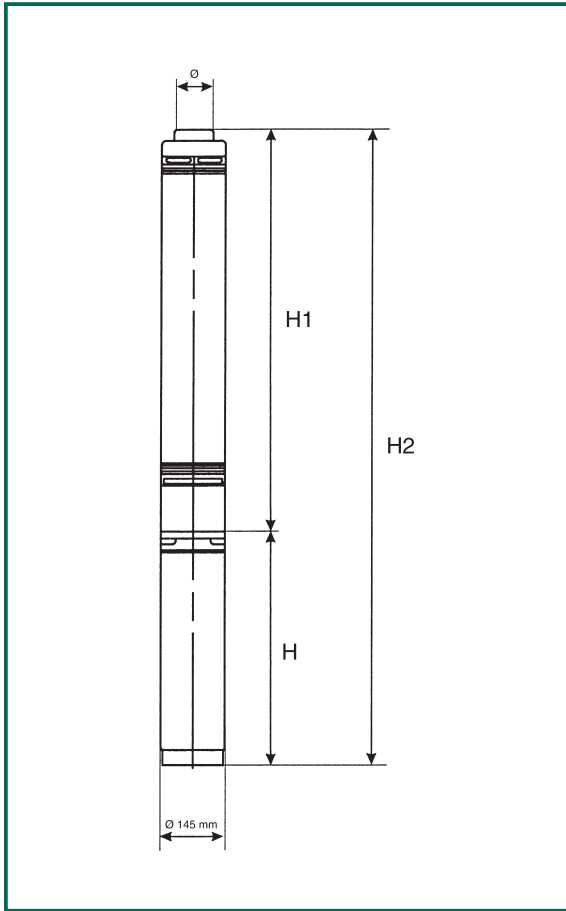

MODEL	P2 NOMINAL		HYDRAULIC DATA (n ≈ 2850 1/min)							H1 (mm)	H2 (mm)	Weight of pump	Total weight	Ø	
	kW	HP	Q												
			m ³ /h	0	12	15	18	24	36						
S6F-4	4	5	l/min	0	200	250	300	400	600						
S6F-6	5,5	7,5		61	53	51	48	40	15	511	1111	10	49,5	3"	
S6F-8	7,5	10		91	80	76	71	59	22	625	1256	11	54,2	3"	
S6F-10	9,2	12,5		122	106	101	95	79	30	738	1398	13	58,5	3"	
S6F-12	11	15		152	133	126	119	99	37	852	1537	14,5	63,5	3"	
S6F-14	13	17,5		182	159	154	143	119	47	966	1696	16	69	3"	
S6F-16	15	20		213	186	178	167	139	56	1079	1864	17,5	76,5	3"	
S6F-20	18,5	25		243	212	204	190	158	64	1193	1978	20	79	3"	
S6F-24	22	30		304	265	255	238	198	80	1474	2334	24	90,5	3"	
S6F-24				365	318	305	286	238	96	1700	2620	27,5	100	3"	

MODEL	MOTORS										
	H (mm)	WEIGHT Kg.	Axial load N	1/m	Power input 50 Hz	Installed Power kW	HP	I _N	I _A	η (%)	cos φ
S6F-4	600	39,5	16000	2845	3X400 V ~	4	5,5	10,6	43	76	0,75
S6F-6	631	43,2	16000	2840	3X400 V ~	5,5	7,5	14	65	76	0,75
S6F-8	660	45,5	16000	2840	3X400 V ~	7,5	10	18	74	78	0,78
S6F-10	685	49	16000	2840	3X400 V ~	9,2	12,5	22	85	80	0,8
S6F-12	730	53	16000	2840	3X400 V ~	11	15	25,5	113	79	0,82
S6F-14	785	59	16000	2840	3X400 V ~	15	20	33,4	160	83	0,8
S6F-16	785	59	16000	2840	3X400 V ~	15	20	33,4	160	83	0,8
S6F-20	860	66,5	16000	2845	3X400 V ~	18,5	25	41	215	83	0,8
S6F-24	920	72,5	16000	2825	3X400 V ~	22	30	47	240	83	0,84

The performance curves are based on kinematic viscosity values = 1 mm²/s and density equivalent to 1000 kg/m³. Tolerance of curves to ISO 9906.

S6H

Maximum ambient temperature: 30°C

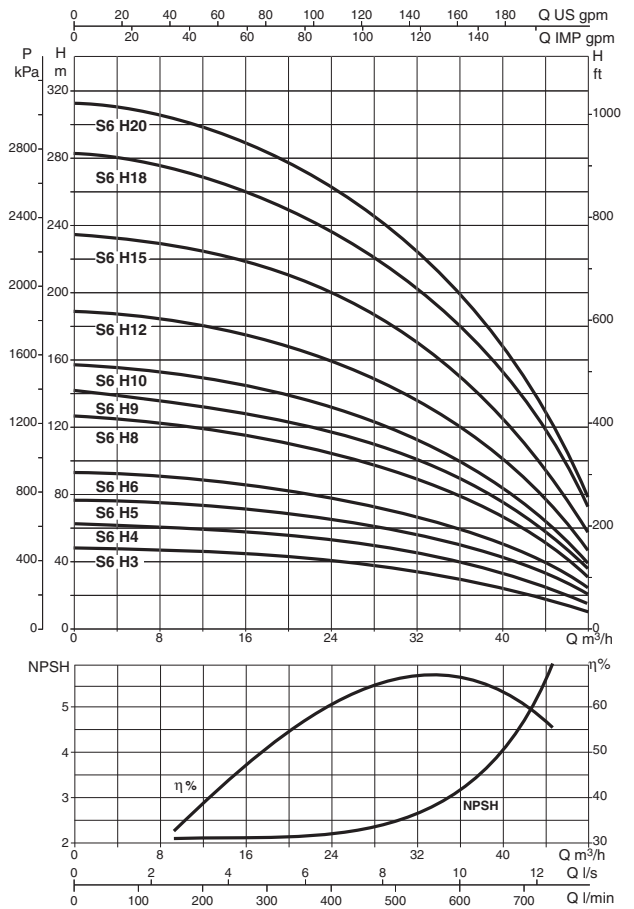
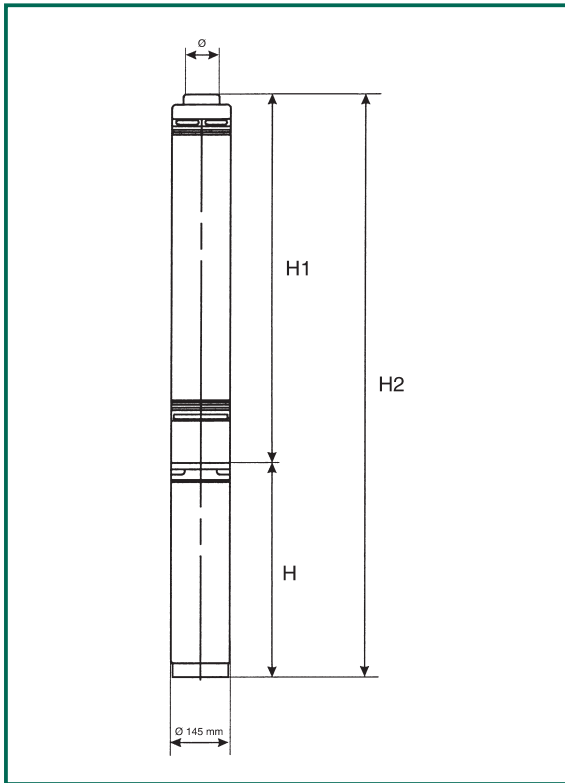

MODEL	P2 NOMINAL		HYDRAULIC DATA (n = 2850 1/min)						H1 (mm)	H2 (mm)	Weight of pump	Total weight	Ø
	kW	HP	Q										
			m ³ /h	0	18	24	36	48					
			l/min	0	300	400	600	800					
S6H-3	4	5,5		48	42	39	30	12	463	1063	7,5	47	3"
S6H-4	5,5	7,5		63	57	53	40	16	522	1153	8,5	51,7	3"
S6H-5	7,5	10		78	71	66	50	20	582	1242	9,5	55	3"
S6H-6	9,2	12,5		94	85	80	60	23	642	1327	10,5	59,5	3"
S6H-8	11	15		126	114	106	80	31	762	1492	12	65	3"
S6H-9	13	17,5		141	128	120	90	35	822	1607	14	73	3"
S6H-10	15	20		157	142	133	100	39	882	1667	14	74	3"
S6H-12	18,5	25		188	170	160	120	47	1002	1862	16	82,5	3"
S6H-15	22	30		235	213	199	150	59	1182	2102	19	91,5	3"
S6H-18	26	35		283	256	239	180	71	1414	2464	22	107	3"
S6H-20	30	40		314	284	266	200	78	1534	2584	25	110	3"

MODEL	MOTORS										
	H (mm)	WEIGHT Kg.	Axial load N	1/m	Power input 50 Hz	Installed Power		I _N	I _A	η (%)	cos φ
S6H-3	600	39,5	16000	2845	3X400 V ~	4	5,5	10,6	43	76	0,75
S6H-4	631	43,2	16000	2840	3X400 V ~	5,5	7,5	14	65	76	0,75
S6H-5	660	45,5	16000	2840	3X400 V ~	7,5	10	18	74	78	0,78
S6H-6	685	49	16000	2840	3X400 V ~	9,2	12,5	22	85	80	0,8
S6H-8	730	53	16000	2840	3X400 V ~	11	15	25,5	113	79	0,82
S6H-9	785	59	16000	2840	3X400 V ~	15	20	33,4	160	83	0,8
S6H-10	785	59	16000	2840	3X400 V ~	15	20	33,4	160	83	0,8
S6H-12	860	66,5	16000	2845	3X400 V ~	18,5	25	41	215	83	0,8
S6H-15	920	72,5	16000	2825	3X400 V ~	22	30	47	240	83	0,84
S6H-18	1050	85	27000	2830	3X400 V ~	30	40	61,5	280	85	0,8
S6H-20	1050	85	27000	2830	3X400 V ~	30	40	61,5	280	85	0,8

The performance curves are based on kinematic viscosity values = 1 mm²/s and density equivalent to 1000 kg/m³. Tolerance of curves to ISO 9906.

S6L

Maximum ambient temperature: 30°C

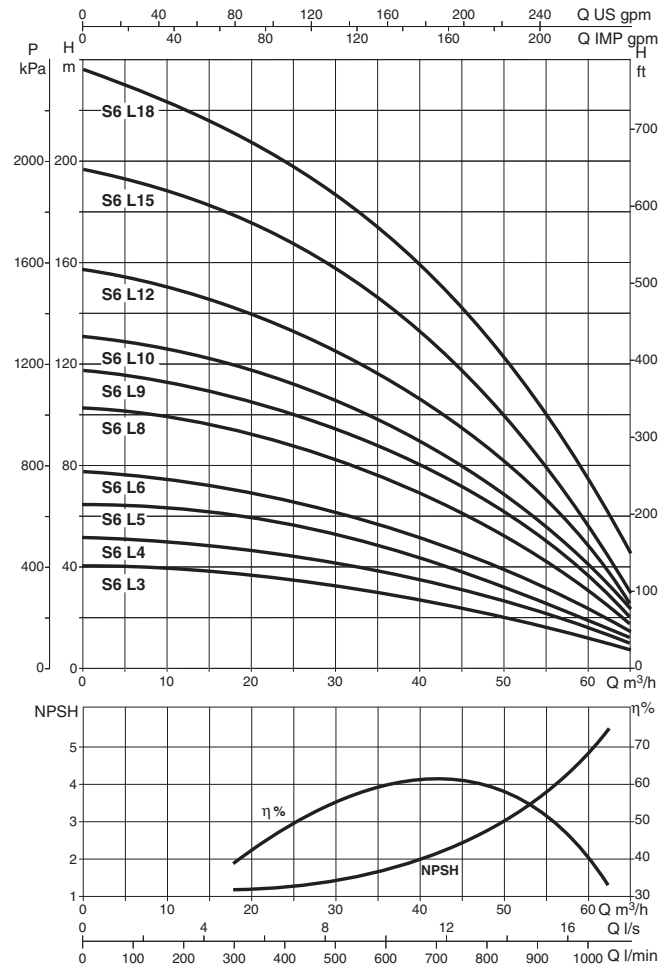
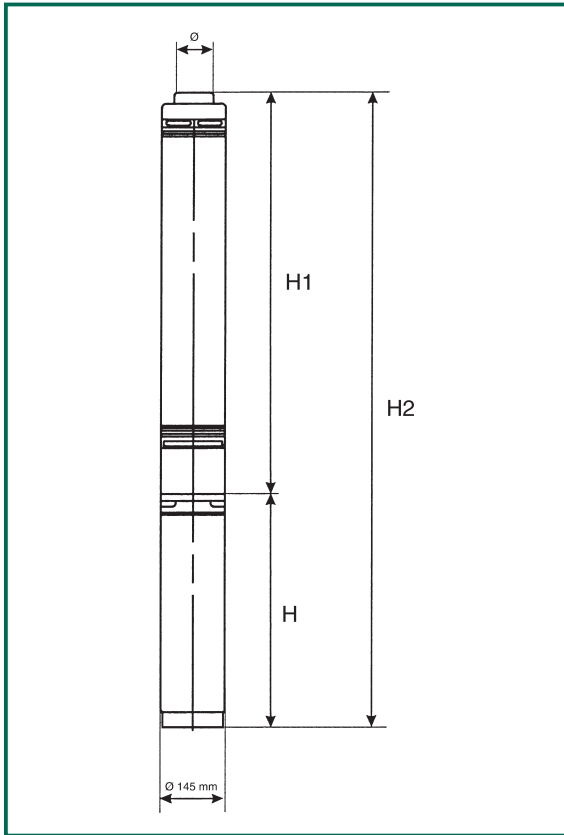

MODEL	P2 NOMINAL		HYDRAULIC DATA (n ≈ 2850 1/min)					H1 (mm)	H2 (mm)	Weight of pump	Total weight	Ø	
	kW	HP	Q										
			m ³ /h	0	36	48	54						66
			l/min	0	600	800	900	1100					
S6L-3	5,5	7,5	H (m)	40	28	22	18	7	463	1094	7,5	50,7	3"
S6L-4	7,5	10		52	38	29	23	9	522	1182	8,5	54	3"
S6L-5	9,2	12,5		65	48	36	29	11	582	1267	9,5	58,5	3"
S6L-6	11	15		78	57	44	36	13	642	1372	10,5	63,5	3"
S6L-8	13	17,5		104	77	58	47	18	762	1547	12	71	3"
S6L-9	15	20		118	86	66	53	20	822	1607	13	72	3"
S6L-10	18,5	25		131	96	73	59	23	882	1742	14	80,5	3"
S6L-12	22	30		158	114	88	71	27	1002	1922	16	88,5	3"
S6L-15	26	35		197	144	110	89	34	1182	2232	19	104	3"
S6L-18	30	40		236	173	130	106	41	1414	2464	22	107	3"

MODEL	MOTORS										
	H (mm)	WEIGHT Kg.	Axial load N	1/m	Power input 50 Hz	Installed Power		I _N	I _A	η (%)	cos φ
S6L-3	631	43,2	16000	2840	3X400 V ~	5,5	7,5	14	65	76	0,75
S6L-4	660	45,5	16000	2840	3X400 V ~	7,5	10	18	74	78	0,78
S6L-5	685	49	16000	2840	3X400 V ~	9,2	12,5	22	85	80	0,8
S6L-6	730	53	16000	2840	3X400 V ~	11	15	25,5	113	79	0,82
S6L-8	785	59	16000	2840	3X400 V ~	15	20	33,4	160	83	0,8
S6L-9	785	59	16000	2840	3X400 V ~	15	20	33,4	160	83	0,8
S6L-10	860	66,5	16000	2845	3X400 V ~	18,5	25	41	215	83	0,8
S6L-12	920	72,5	16000	2825	3X400 V ~	22	30	47	240	83	0,84
S6L-15	1050	85	27000	2830	3X400 V ~	30	40	61,5	280	85	0,8
S6L-18	1050	85	27000	2830	3X400 V ~	30	40	61,5	280	85	0,8

CONTROL AND PROTECTION SYSTEMS

FOR 6" BOREHOLE PUMPS

ES 7,5 T

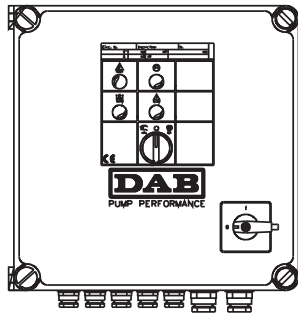

Control box for dry run protection of submerged three-phase electric pumps (see table).

The control box is protected and it protects the electric pump from overloads and short circuits, with manual reset. Complete with:

- Terminals for min/max level control (with float switches, pressure switches, etc.)
- Terminals for connection of a remote control
- Pump manual/automatic operation selector
- Timer to control stop time to protect against dry running.
- Protection against excessive number of starts (can be bypassed).
- Terminals (voltage-free) for remote feeding of an audible alarm.

Facility for operation with 1, 2 or 3 sensors, depending on application.

Protection rating IP 55.

Operating range: from -10°C to +40°C

Supplied as standard with an electric probe and wall-mounting brackets.

Wall-mounting box in self-extinguishing thermoplastic.

MODEL	POWER INPUT 50-60 Hz	POWER KW P2 MOT.	NOM. DUTY POWER (MAX.) (KW)	MAX. CURRENT A	DIMENSIONS			GROSS WEIGHT kg
					A	B	H	
ES 7,5 T	3x400 V~	4-5,5	7,5	14	270	300	190	5,6

ES 10 T

ES 12,5 T

ES 15 T

ES 20 T

ES 25 T

ES 30 T

ES 40 T

Control boxes for protection and automatic operation with float switch(es) of borehole three-phase electric pumps in single installations.

Available for direct starting and for start delta starting.

Wall-mounting box in self-extinguishing thermoplastic.

The control box is self-protected and it protects the pump from overloads, short circuits and phase loss, with manual reset.

Complete with:

- Power line disconnect device with padlockable door lock handle;
- Self-protected transformer to provide 24V supply for external controls;
- Terminals to connect pump and minimum/maximum level float switches;
- Probes module for anti dry-run control;
- Terminals to connect alarm control for remote installation of a sounder or warning light (voltage free)
- Manual – 0 – automatic selector on control box front panel;
- Indicators on control box front panel:
 - Red warning light: overload protection trip;
 - Green indicator light: pump running status;
 - Yellow indicator light: control circuits correct operation
- Operating ambient temperature limits -10°C +40°C
- Storage temperature limits: -25°C +55°C
- Air relative humidity (non-condensing): 50% at 40°C MAX (90% at 20°C)
- Max. altitude: 3000 m a.s.l.
- Protection rating: IP55
- Construction of electrical enclosures: to EN 60204-1 and EN 60439-1
- Supplied as standard with an electric probe

MODEL	POWER INPUT 50-60 Hz	POWER KW P2 MOT.	MAX. CURRENT A	DIMENSIONS			GROSS WEIGHT kg
				A	B	H	
ES 10 T	400V	7,5	18	270	270	165	5,6
ES 12,5 T	400V	9,2	25	270	270	165	5,9
ES 15 T	400V	11	25	270	360	165	8
ES 20 T	400V	15	32	270	360	165	8,1
ES 25 T	400V	18,5	40	270	360	165	8,3
ES 30 T	400V	22	63	270	360	165	8,5
ES 40 T	400V	30	80	270	360	165	8,7

Electrode probe

For use with ES control boxes for supervision of dry running/level control.

Suitable for conductive liquids with temperature up to +40°C.

Can be connected to electrical panel using 1.5 mm² cable with 550V insulation capacity (not supplied).



6" SUBMERGED MOTOR series 6GF



Submerged 6" asynchronous two-pole motor made of AISI 304 stainless steel and cast iron with paint coating. Cooling of the thrust bearing and the bushings is provided by a mixture of water and glycol. Squirrel cage rotor in copper mounted on Kingsbury self-centring thrust block. Stator housed in an airtight AISI 304L stainless steel casing. Ceramic-alumina mechanical seal. Flanging to NEMA 6". Protection rating IP 68. Heat insulation class F. Removable connector. Vertical/horizontal operation (ensure a minimum load is applied to the thrust bearing assembly). Maximum working depth: 300 m. Motor suitable for use with variable frequency drive (30Hz-50Hz). Overload protection to be provided by the user for the three-phase version.

Motor construction characteristics

STATOR. Canned-type stator in an airtight casing made of AISI 304L stainless steel. Insulation class F. Compatible with up to 25 starts per hour.

POWER CABLE. All motors are supplied as standard with a 4-core power cable that can be easily and quickly removed prior to disassembly/reassembly of the motor or parts of the pump, thereby avoiding the risk of damaging the cable.

SUPPORTS. The upper and lower supports are made of G20 cast iron, protected with an electrophoresis paint coating and equipped with carbon-graphite bushings.

THRUST BEARINGS SYSTEM.

Kingsbury type thrust bearings with lapped pads in stainless steel.

The special design and machining process ensure high reliability and long life.

Thrust bearing systems vary in compliance with the various different installed power values:

from 5.5 hp to 30 hp class 16000 N

from 40 hp to 50 hp class 27000 N

ROTOR SHAFT in stainless steel, with extremity section in "Duplex"

MECHANICAL SEAL All 6GF motors are equipped with a ceramic-alumina mechanical seal. A silicon carbide mechanical seal can be fitted on request.

Available in a version equipped with a PT100 temperature sensor

MODEL		Power input 50 Hz V	In A	Ist A	P1 Max W	Rpm N	cosφ	Eff. ?	Starts	Axial thrust N	Length mm	Weight Kg	CABLE	
Hp	KW												Cross section mm²	Length m
5,5	4	230	18,4	74	5290	2845	0,75	76	?	16000	600	39,5	4 x 4	4
		400	10,6	43	5290	2845	0,75	76	Y					
		415	11	47	5500	2860	0,7	73	Y					
		400/690	10,6	14	5290	2845	0,75	76	Y/?					
7,5	5,5	230	24,3	112	7270	2845	0,75	76	?	16000	631	43,2	4 x 4	4
		400	14	65	7270	2845	0,75	76	Y					
		415	14,6	70	7330	2860	0,71	73	Y					
		400/690	14	22	7220	2845	0,75	76	Y/?					
10	7,5	230	31,2	128	9550	2840	0,78	78	?	16000	660	45,5	4 x 4	4
		400	18	74	9550	2840	0,78	78	Y					
		415	18,3	80	9700	2850	0,73	77	Y					
		400/690	18	25	9550	2840	0,78	78	Y/?					
12,5	9,2	230	37,3	147	11460	2840	0,8	80	?	16000	685	49	4 x 4	4
		400	22	85	11460	2840	0,8	80	Y					
		415	22,8	95	11600	2850	0,79	79	Y					
		400/690	22	28	11460	2840	0,8	80	Y/?					
15	11	230	44,2	195	13860	2840	0,82	79	?	16000	730	53	4 x 6	4
		400	25,5	113	13860	2840	0,82	79	Y					
		415	26	125	14100	2850	0,79	78	Y					
		400/690	25,5	37	13860	2840	0,82	79	Y/?					
20	15	230	57,8	277	17960	2840	0,8	83	?	16000	785	59	4 x 6	4
		400	33,4	160	17960	2840	0,8	83	Y					
		415	34,2	170	18200	2850	0,76	82	Y					
		400/690	33,4	53	18200	2840	0,8	83	Y/?					
25	18,5	230	71	370	22300	2845	0,8	83	?	16000	860	66,5	4 x 8	4
		400	41	215	22300	2845	0,8	83	Y					
		415	42	230	22450	2855	0,73	82	Y					
		400/690	41	72	22300	2845	0,8	83	Y/?					
30	22	230	81,4	415	26500	2825	0,84	83	?	16000	920	72,5	4 x 8	4
		400	47	240	26500	2825	0,84	83	Y					
		415	47,5	257	26850	2835	0,08	82	Y					
		400/690	47	80	26500	2825	0,84	83	Y/?					
40	30	400	61,5	280	35130	2830	0,85	85	Y	27000	1050	85	4 x 8	4
		415	63,5	296	35600	2840	0,8	84	Y					
		400/690	61,5	93	35130	2830	0,85	85	Y/?					
50	37	400	79,5	296	44200	2820	0,87	0,82	Y	27000	1180	98	4 x 8	4
		415	79,3	310	44200	2830	0,84	0,81	Y					
		400/690	80	320	44200	2840	0,8	0,81	Y/?					

COMPONENT	MATERIAL	TYPE
Internal sleeve and outer casing	Stainless steel	AISI 304 L
Shaft extension	Stainless steel	Duplex
Upper support	Painted cast iron	
Mechanical seal	Carbon-Ceramic	or SIC/SIC
Gaskets	Rubber	NBR
Lower support	Painted cast iron	AISI 304
Lower cap	Stainless steel	AISI 304
Bellow seal	Rubber	NBR
Thrust bearings	Steel-Graphite	
Valve	Brass	
Cable	Rubber	EPDM
Connector plug	Stainless steel	AISI 304
Sand guard (fixed-mobile)	Rubber	NBR
Screws	Stainless steel	AISI 304
Coolant:	Antifreeze+Water	

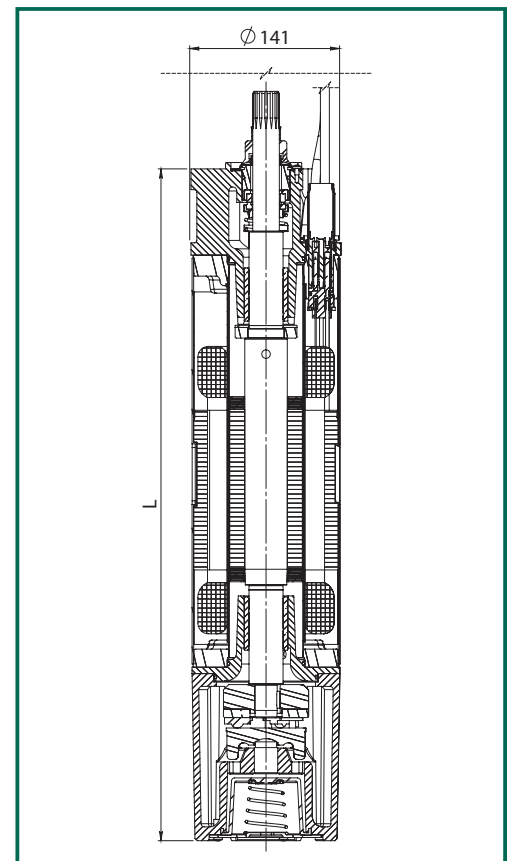

6" SUBMERGED MOTOR series 6GX



Submerged 6" asynchronous two-pole motor made entirely of AISI 316 stainless steel for use in aggressive/salt water. Cooling of the thrust bearing and the bushings is provided by a mixture of water and glycol. Squirrel cage rotor in copper mounted on Kingsbury self-centring thrust block. Stator housed in an airtight AISI 316 stainless steel casing. Mechanical seal in silicon carbide. Flanging to NEMA 6". Protection rating IP 68. Heat insulation class F. Removable connector. Vertical/horizontal operation (ensure a minimum load is applied to the thrust bearing assembly). Maximum working depth: 300m. Motor suitable for use with variable frequency drive (30Hz-50Hz). Motor overload protection to be provided by the user.

Motor construction characteristics

STATOR. Canned-type stator in an airtight casing made of stainless steel with flanges and jacket in AISI 316 stainless steel.

Insulation class F. Compatible with up to 25 starts per hour.

POWER CABLE. All motors are supplied as standard with a 4-core power cable that can be easily and quickly removed prior to disassembly/reassembly of the motor or parts of the pump, thereby avoiding the risk of damaging the cable.

SUPPORTS. The upper and lower supports are made entirely of AISI 316 and equipped with carbon-graphite bushings.

THRUST BEARINGS SYSTEM.

Kingsbury type thrust bearings with lapped pads in stainless steel.

The special design and machining process ensure high reliability and long life.

Thrust bearing systems vary in compliance with the various different installed power values:

from 5.5 hp to 30 hp	class 16000 N
from 40 hp to 50 hp	class 27000 N

ROTOR SHAFT in stainless steel, with extremity section in "Duplex"

MECHANICAL SEAL All 6GX motors are equipped with a silicon carbide mechanical seal.

Available in a version equipped with a PT100 temperature sensor

MODEL		Power input 50 Hz V	In A	Ist A	P1 Max W	Rpm N	cosφ	Eff. ?	Starts	Axial thrust N	Length mm	Weight Kg	CABLE	
Hp	KW												Cross section mm²	Length m
5,5	4	230	18,4	74	5290	2845	0,75	76	?	16000	600	39,5	4 x 4	4
		400	10,6	43	5290	2845	0,75	76	Y					
		415	11	47	5500	2860	0,7	73	Y					
		400/690	10,6	14	5290	2845	0,75	76	Y/?					
7,5	5,5	230	24,3	112	7270	2845	0,75	76	?	16000	631	43,2	4 x 4	4
		400	14	65	7270	2845	0,75	76	Y					
		415	14,6	70	7330	2860	0,71	73	Y					
		400/690	14	22	7220	2845	0,75	76	Y/?					
10	7,5	230	31,2	128	9550	2840	0,78	78	?	16000	660	45,5	4 x 4	4
		400	18	74	9550	2840	0,78	78	Y					
		415	18,3	80	9700	2850	0,73	77	Y					
		400/690	18	25	9550	2840	0,78	78	Y/?					
12,5	9,2	230	37,3	147	11460	2840	0,8	80	?	16000	685	49	4 x 4	4
		400	22	85	11460	2840	0,8	80	Y					
		415	22,8	95	11600	2850	0,79	79	Y					
		400/690	22	28	11460	2840	0,8	80	Y/?					
15	11	230	44,2	195	13860	2840	0,82	79	?	16000	730	53	4 x 6	4
		400	25,5	113	13860	2840	0,82	79	Y					
		415	26	125	14100	2850	0,79	78	Y					
		400/690	25,5	37	13860	2840	0,82	79	Y/?					
20	15	230	57,8	277	17960	2840	0,8	83	?	16000	785	59	4 x 6	4
		400	33,4	160	17960	2840	0,8	83	Y					
		415	34,2	170	18200	2850	0,76	82	Y					
		400/690	33,4	53	18200	2840	0,8	83	Y/?					
25	18,5	230	71	370	22300	2845	0,8	83	?	16000	860	66,5	4 x 8	4
		400	41	215	22300	2845	0,8	83	Y					
		415	42	230	22450	2855	0,73	82	Y					
		400/690	41	72	22300	2845	0,8	83	Y/?					
30	22	230	81,4	415	26500	2825	0,84	83	?	16000	920	72,5	4 x 8	4
		400	47	240	26500	2825	0,84	83	Y					
		415	47,5	257	26850	2835	0,08	82	Y					
		400/690	47	80	26500	2825	0,84	83	Y/?					
40	30	400	61,5	280	35130	2830	0,85	85	Y	27000	1050	85	4 x 8	4
		415	63,5	296	35600	2840	0,8	84	Y					
		400/690	61,5	93	35130	2830	0,85	85	Y/?					
50	37	400	79,5	296	44200	2820	0,87	0,82	Y	27000	1180	98	4 x 8	4
		415	79,3	310	44200	2830	0,84	0,81	Y					
		400/690	80	320	44200	2840	0,8	0,81	Y/?					

COMPONENT	MATERIAL	TYPE
Outer sleeve	Stainless steel	AISI 316 Ti
Shaft extension	Stainless steel	Duplex
Upper support	Stainless steel	AISI 316
Mechanical seal		SIC/SIC
Gaskets	Rubber	VITON
Lower support	Stainless steel	AISI 316
Lower cap	Stainless steel	AISI 316
Bellow seal	Rubber	EPDM
Thrust bearings	Steel-Graphite	
Valve	Stainless steel	AISI 316
Cable	Rubber	EPDM
Connector plug	Stainless steel	AISI 316
Sand guard (fixed-mobile)	Rubber	EPDM
Screws	Stainless steel	AISI 316
Coolant	Antifreeze+Water	

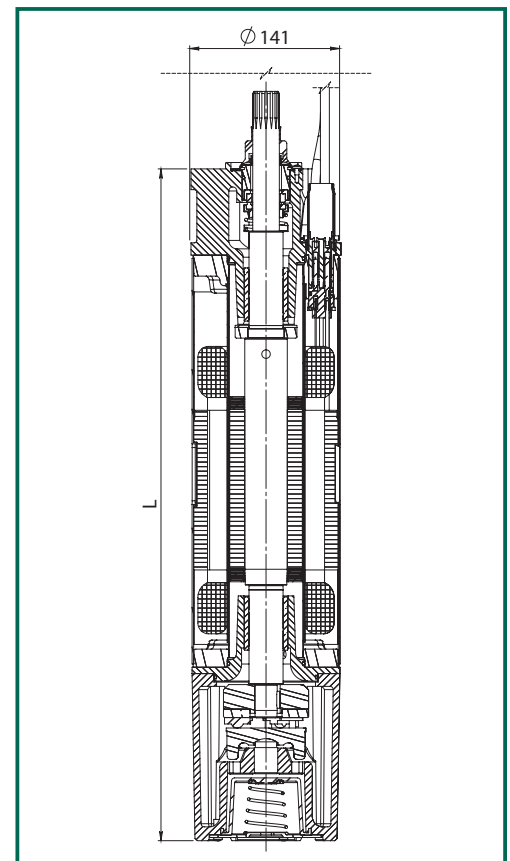

6" SUBMERGED MOTOR series TR6



Submerged asynchronous two-pole three-phase rewindable motor, made, in the standard version, of AISI 304L stainless steel and cast iron. The rotor is mounted on a Mitchell thrust block. Cooling and lubrication of the thrust bearing and the bushings is provided by a mixture of water and glycol.

Flanging to NEMA 6". Protection rating IP 58 (IP68 on request).

Vertical / horizontal operation (ensure a minimum load is applied to the thrust bearing assembly).

Maximum working depth: 300m. Motor overload protection to be provided by the user.

Motor for industrial and agricultural applications featuring highly personalisable construction that allows easy and comprehensive maintenance and repair in-situ with reduced times and costs.

Motor construction characteristics

STATOR. The rewindable stator is protected by an AISI 304 stainless steel jacket (AISI 316 or 904 on request). In the standard version the rotor is wound with PVC coated wire offering superior dielectric properties that allow direct contact with the coolant. On request, we can supply a version with a PE2+PA winding that makes the motor compatible with special applications and with the use of a variable frequency drive. The motor can be supplied for different input voltages and frequencies.

POWER CABLE. All motors are supplied as standard with a 5 m 3-core power cable connected directly to the winding. ACS and WRAS certified cable. Motor available in DOL and SD version.

SUPPORTS. The upper and lower supports are made of painted cast iron (standard version) and equipped with carbon-graphite bushings. The lower support incorporates the EPDM membrane designed to compensate for motor internal pressure.

Available in AISI 316 or 904 stainless steel on request.

THRUST BEARINGS SYSTEM.

Mitchell type thrust bearings with lapped pads in stainless steel and graphite clearance ring .

from 5 hp to 20 hp	15000 N
from 25 hp to 50 hp	25000 N
Counter-thrust load	6000N

ROTOR SHAFT Rotor shaft in stainless steel. The rotor is made of die cast aluminium up to 20 Hp and in copper for all other sizes.

MECHANICAL SEAL In the standard version, up to 25 Hp the motor is equipped with a ceramic/carbon mechanical seal. For higher power ratings than 30 Hp the motor is also equipped with a lip seal (IP 68). On request we can supply a silicon carbide mechanical seal (SiC/SiC)

3x400 V - 50 Hz*

MOTOR				Current I _n [A]	Motor efficiency η [%]			Power factor			I _{start} /I _n	L [mm]	Weight [Kg]
Type	Dimens.	Power [kW]	Power [hp]		50%	75%	100%	50%	75%	100%			
TR6	6"	3,7	5	9,85	67	70	70	0,63	0,75	0,81	4,0	630	45
		5,5	7,5	14	75	76	74	0,62	0,75	0,81	3,7	660	48
		7,5	10	18,4	77	79	77	0,60	0,73	0,80	3,7	690	50
		9,2	12,5	22,4	77	78	77	0,64	0,76	0,81	3,6	720	55
		11	15	26	78	79	78	0,65	0,77	0,82	3,7	780	60
		13	17,5	30	81	81	80	0,64	0,76	0,82	3,8	850	72
		15	20	34	82	82	81	0,66	0,79	0,83	3,8	910	78
		18,5	25	40,5	83	85	84	0,64	0,77	0,83	5,3	1085	90
		22	30	51,5	81	83	83	0,57	0,70	0,79	5,5	1087	95
		26	35	61	81	83	83	0,57	0,70	0,78	5,7	1157	105
		30	40	68,2	83	84	84	0,61	0,73	0,81	5,0	1212	110
37	50	84,5	82	84	83	0,60	0,73	0,81	5,1	1312	120		

* on request different voltages and frequencies are available

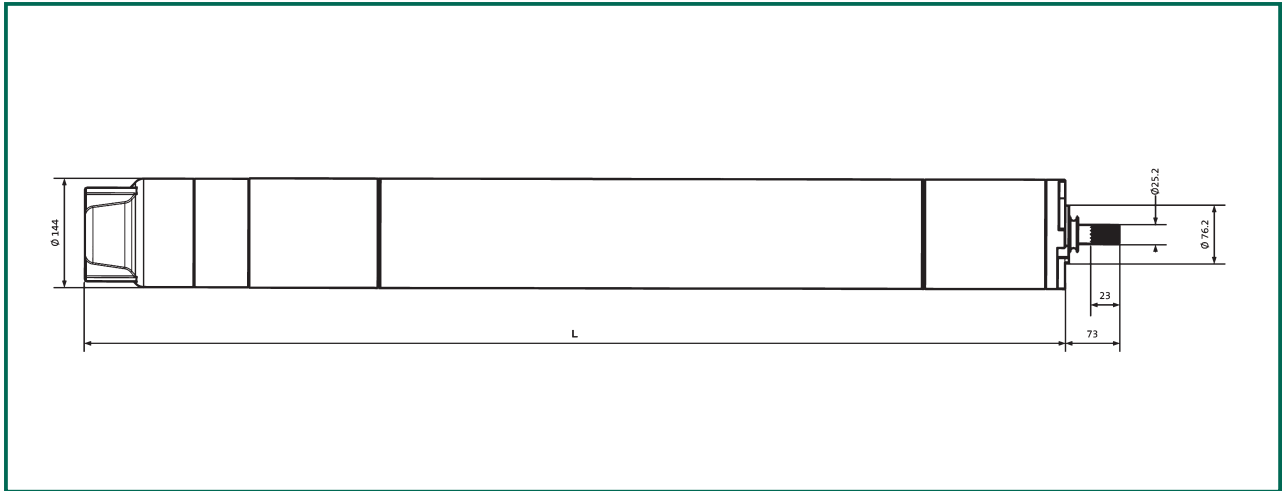

8" SUBMERGED MOTOR series TR8



Submerged asynchronous two-pole three-phase rewindable motor, made, in the standard version, with an AISI 316 stainless steel jacket with cast iron supports. The rotor is mounted on a Mitchell thrust block. Cooling and lubrication of the thrust bearing and the bushings is provided by a mixture of water and glycol. Flanging to NEMA 8". Protection rating IP 58 (IP68 on request).

Vertical / horizontal operation (ensure a minimum load is applied to the thrust bearing assembly).

Maximum working depth: 300m. Motor overload protection to be provided by the user.

Motor for industrial and agricultural applications featuring highly personalisable construction that allows easy and comprehensive maintenance and repair in situ with reduced times and costs.

Available also in a four-pole version with power range from 15 HP to 60 HP.

Motor construction characteristics

STATOR. The rewindable stator is protected by an AISI 316 stainless steel jacket (AISI 904 on request). In the standard version the rotor is wound with PVC coated wire offering superior dielectric properties that allow direct contact with the coolant. On request, we can supply a version with a PE2+PA winding that makes the motor compatible with special applications and with the use of a variable frequency drive. The motor can be supplied for different input voltages and frequencies.

POWER CABLE. All motors are supplied as standard with a 5 m 3-core power cable connected directly to the winding. ACS and WRAS certified cable. Motor available in DOL and SD version.

SUPPORTS. The upper and lower supports are made of painted cast iron (standard version) and equipped with carbon-graphite bushings. The lower support incorporates the EPDM membrane designed to compensate for motor internal pressure.

Available in AISI 316 or 904 stainless steel on request.

THRUST BEARINGS SYSTEM.

Mitchell type thrust bearings with lapped pads in graphite steel and ceramic clearance ring.

from 30 hp to 150 hp 60000 N

Counter-thrust load 12500N

ROTOR SHAFT Rotor shaft in stainless steel. The rotor is made of copper for all sizes

MECHANICAL SEAL In the standard version the motor is equipped with a ceramic/carbon mechanical seal. On request we can supply a silicon carbide mechanical seal (SiC/SiC)

3x400 V - 50 Hz*

Type	Dimens.	MOTOR		Current I _n [A]	Motor efficiency η [%]			Power factor			I _{start} /I _n	L [mm]	Weight [Kg]
		Power [kW]	Power [hp]		50%	75%	100%	50%	75%	100%			
TR8	8"	22	30	48	80	82	82	0,72	0,81	0,84	5,3	1010	126
		26	35	56,5	80	82	82	0,76	0,83	0,85	5,1	1050	134
		30	40	64	82	84	84	0,74	0,82	0,85	5,7	1110	146
		37	50	78,5	82	84	84	0,74	0,82	0,85	5,7	1160	156
		45	60	96,5	84	86	86	0,65	0,76	0,82	6	1270	177
		55	75	114	84	86	86	0,72	0,81	0,85	5,9	1350	192
		63	85	132	85	87	87	0,66	0,78	0,83	5,7	1490	218
		75	100	152	86	87	87	0,71	0,82	0,86	5,8	1590	237
		92	125	186	87	88	87	0,72	0,82	0,86	5,9	1830	283
		110	150	224	86	87	87	0,73	0,83	0,87	5,8	2060	333

* on request different voltages and frequencies are available

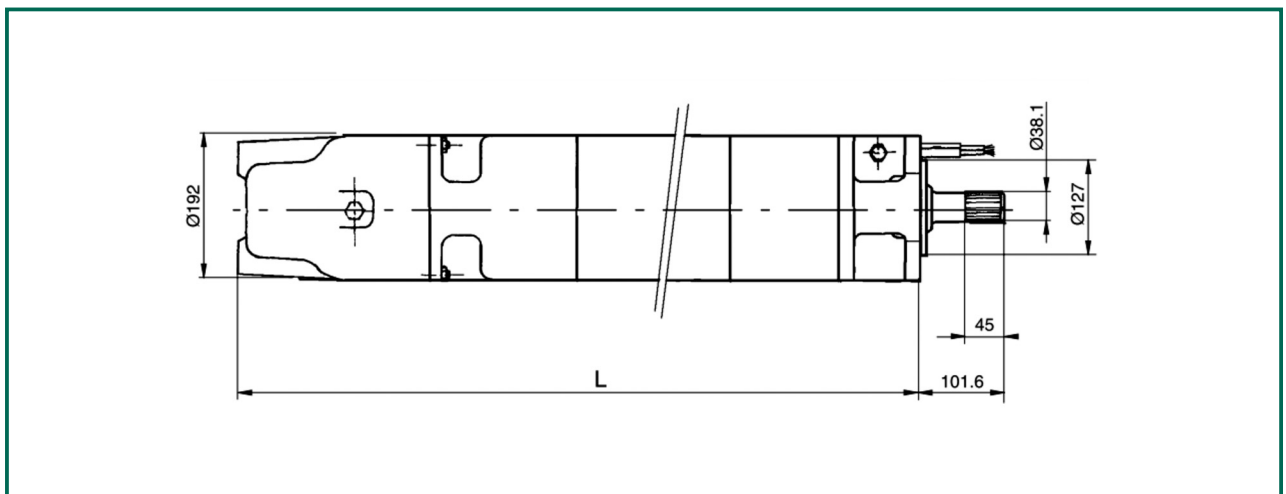

10" SUBMERGED MOTOR series TR10



CE

Submerged asynchronous two-pole three-phase rewindable motor, made, in the standard version, with a jacket in AISI 316 stainless steel, and equipped with cast iron support. The rotor is mounted on a Mitchell thrust block. Cooling and lubrication of the thrust bearing and the bushings is provided by a mixture of water and glycol.

Protection rating IP 58 (IP68 on request).

Vertical / horizontal operation (ensure a minimum load is applied to the thrust bearing assembly).

Maximum working depth: 300m. Motor overload protection to be provided by the user.

Motor for industrial and agricultural applications featuring highly personalisable construction that allows easy and comprehensive maintenance and repair in situ with reduced times and costs.

Available also in a four-pole version with power rating from 40 HP to 150 HP.

Motor construction characteristics

STATOR. The rewindable stator is protected by an AISI 316 stainless steel jacket (AISI 904 on request). In the standard version the rotor is wound with PVC coated wire offering superior dielectric properties that allow direct contact with the coolant. On request, we can supply a version with a PE2+PA winding that makes the motor compatible with special applications and with the use of a variable frequency drive. The motor can be supplied for different input voltages and frequencies.

POWER CABLE. All motors are supplied as standard with 8 m single-core cables, connected directly to the winding. ACS and WRAS certified cable. Motor available in DOL and SD version.

SUPPORTS. The upper and lower supports are made of painted cast iron (standard version) and equipped with carbon-graphite bushings. The lower support incorporates the EPDM membrane designed to compensate for motor internal pressure.

Available in AISI 316 or 904 stainless steel on request.

THRUST BEARINGS SYSTEM.

Mitchell type thrust bearings with lapped pads in graphite steel and ceramic clearance ring.

from 100 hp to 260 hp 60000 N

Counter-thrust load 12500N

ROTOR SHAFT Rotor shaft in stainless steel. The rotor is made of copper for all sizes

MECHANICAL SEAL In the standard version the motor is equipped with a ceramic/carbon mechanical seal. On request we can supply a silicon carbide mechanical seal (SiC/SiC)

3x400 V - 50 Hz*

MOTOR				Current In [A]	Motor efficiency η [%]			Power factor			I start/In	L [mm]	Weight [Kg]
Type	Dimens.	Power [kW]	Power [hp]		50%	75%	100%	50%	75%	100%			
TR10	10''	75	100	156	84	86	87	0,7	0,8	0,84	5,4	1400	280
		92	125	194	84	87	87	0,67	0,78	0,82	5,6	1500	330
		110	150	228	85	87	88	0,7	0,79	0,84	5,7	1690	385
		132	180	270	85	88	88	0,72	0,81	0,84	5,7	1870	435
		147	200	315	84	87	87	0,64	0,75	0,81	6,2	2070	500
		170	230	365	84	86	87	0,64	0,75	0,81	6	2220	540
		190	260	425	83	86	87	0,6	0,72	0,79	5,9	2400	580

* on request different voltages and frequencies are available

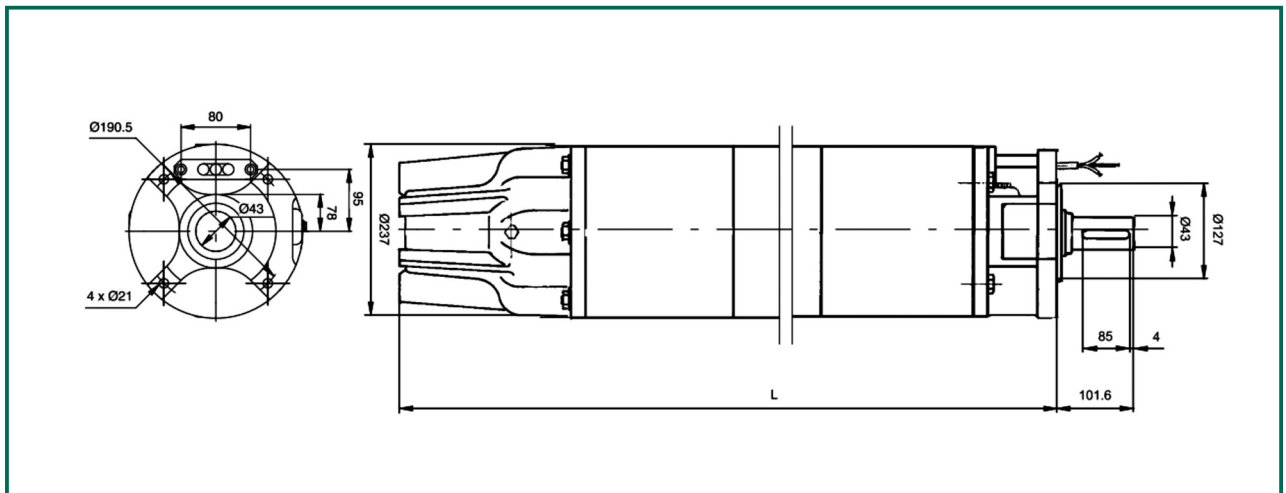

12" SUBMERGED MOTOR series TR12



Submerged asynchronous two-pole three-phase rewindable motor, made, in the standard version, with a jacket in AISI 316 stainless steel, and equipped with cast iron support. The rotor is mounted on a Mitchell thrust block. Cooling and lubrication of the thrust bearing and the bushings is provided by a mixture of water and glycol.

Protection rating IP 58 (IP68 on request).

Vertical/horizontal operation (ensure a minimum load is applied to the thrust bearing assembly).

Maximum working depth: 300 m. Motor overload protection to be provided by the user.

Motor for industrial and agricultural applications featuring highly personalisable construction that allows easy and comprehensive maintenance and repair in situ with reduced times and costs.

Available also in a four-pole version with power rating from 100 HP to 200 HP.

Motor construction characteristics

STATOR. The rewindable stator is protected by an AISI 316 stainless steel jacket. In the standard version the rotor is wound with PVC coated wire (PE2+PA for 300 HP and 340 HP) offering superior dielectric properties that allow direct contact with the coolant. On request, we can supply a version with a PE2+PA winding that makes the motor compatible with special applications and with the use of a variable frequency drive. The motor can be supplied for different input voltages at 50 Hz frequency.

POWER CABLE. All motors are supplied as standard with 8 m single-core cables, connected directly to the winding. ACS and WRAS certified cable. Motor available in DOL and SD version.

SUPPORTS. The upper and lower supports are made of painted cast iron (standard version) and equipped with carbon-graphite bushings. The lower support incorporates the EPDM membrane designed to compensate for motor internal pressure.

Available in AISI 316 stainless steel on request.

THRUST BEARINGS SYSTEM.

Mitchell type thrust bearings with steel pads clad in rubber and steel clearance ring .

from 200 hp to 340 hp: 70000 N

Counter-thrust load: 15000N

ROTOR SHAFT Rotor shaft in stainless steel. The rotor is made of copper for all sizes

MECHANICAL SEAL In the standard version the motor is equipped with a ceramic/carbon mechanical seal. On request we can supply a silicon carbide mechanical seal (SiC/SiC)

3x400 V - 50 Hz*

MOTOR				Current In [A]	Motor efficiency η [%]			Power factor			I start/I _n	L [mm]	Weight [Kg]
Type	Dimens.	Power [kW]	Power [hp]		50%	75%	100%	50%	75%	100%			
TR12	12''	147	200	305	84	87	88	0,66	0,77	0,83	6,2	1790	565
		170	230	345	85	87	88	0,69	0,79	0,85	6,1	1880	605
		190	260	390	85	87	88	0,68	0,8	0,84	6,2	1980	650
		220	300	445	85	87	88	0,69	0,8	0,85	6,1	2110	700
		250	340	505	85	87	88	0,69	0,8	0,85	5,9	2280	775

* on request different voltages and frequencies are available

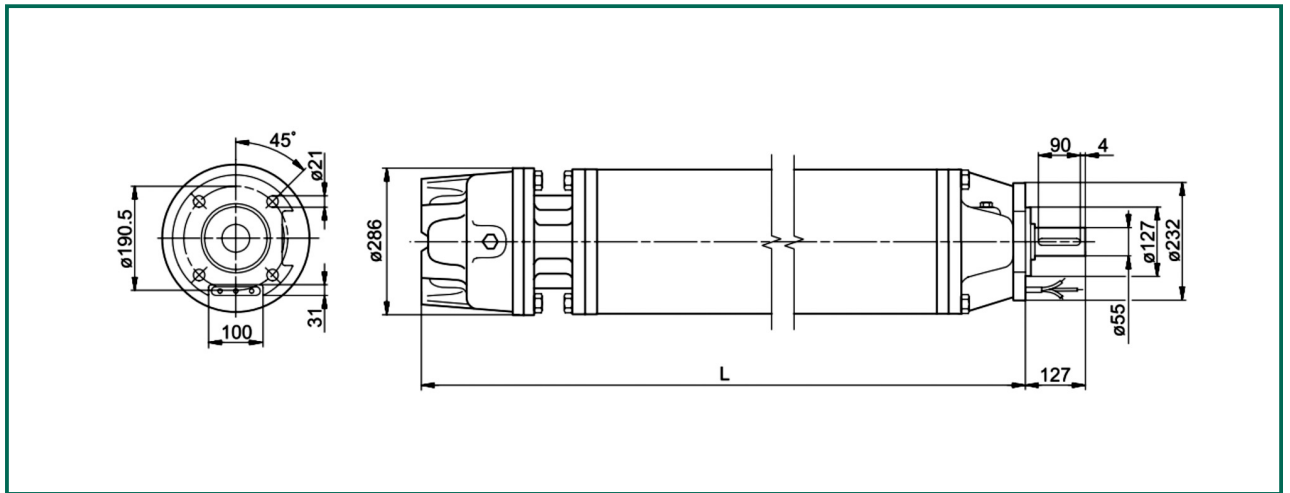

**DAB PUMPS LTD.**

Unit 4, Stortford Hall Industrial
Park Dunmow Road, Bishops Stortford, Herts
CM23 5GZ - UK
Tel. +44 1279 652 776
Fax +44 1279 657 727

**DAB PUMPS B.V.**

Albert Einsteinweg, 4
5151 DL Drunen - Nederland
Tel. +31 416 387280
Fax +31 416 387299
info.nl@dabpumps.com

**DAB PUMPS B.V.**

Brusselstraat 150
B-1702 Groot-Bijgaarden - Belgium
Tel. +32 2 4668353
Fax +32 2 4669218

**DAB PUMPEN DEUTSCHLAND GmbH**

Tackweg 11
D - 47918 Tönisvorst - Germany
Tel. +49 2151 82136-0
Fax +49 2151 82136-36

**PUMPS AMERICA, INC. DAB PUMPS DIVISION**

3226 Benchmark Drive
Ladson, SC 29456 USA
Ph. 1-843-824-6332
Toll Free 1-866-896-4DAB (4322)
Fax 1-843-797-3366

**DAB PUMPS IBERICA S.L.**

Parque Empresarial San Fernando
Edificio Italia Planta 1ª
28830 - San Fernando De Henares - Madrid
Spain
Ph. +34 91 6569545
Fax +34 91 6569676

**DAB PUMPS RUSSIA**

127247 Dmitovskoe sh., 100 bld. 3
Moscow, Russia
Tel. +7 095 485-1679

**DAB PUMPS CHINA**

Shandong Sheng Qingdao Shi
Jinji Jishu Kaifagu Kaituo Rd
ZIP PC266510
CN - China
Tel. +8613608963089
Fax. +8653286812210

**DAB PUMPS S.p.A.**

Via M. Polo, 14 - 35035 Mestrino (PD) - Italy
Tel. +39 049 9048811 - Fax +39 049 9048847
<http://www.dabpumps.com>

Vendite Italia:

Tel. 049 9048873-75-76
049 9048950
Fax 049 9048888

Export Sales Dept:

Ph. (+39) 049 9048895-96-97
049 9048964-996
Fax (+39) 049 9048900

Assistenza Tecnica Clienti:

Customer Technical Assistance: Ph. (+39) 049 9048911
Fax (+39) 049 9048920